

Legacy Device: Motorola MC1490

The ML1490 is an integrated circuit featuring wide-range AGC for use in RF/IF amplifiers and audio amplifiers.

- High Power Gain:
 - 50 dB Typ at 10 MHz
 - 45 dB Typ at 60 MHz
 - 35 dB Typ at 100 MHz
- Wide Range AGC: 60 dB Min, DC to 60 MHz
- 6.0 V to 15 V Operation, Single Polarity Supply
- Operating Temperature Range $T_A = -40^\circ$ to $+85^\circ\text{C}$

Note: See Similar ML1350 For Possible Option

MAXIMUM RATINGS ($T_A = +25^\circ\text{C}$, unless otherwise noted.)

Rating	Symbol	Value	Unit
Power Supply Voltage	V_{CC}	+18	Vdc
AGC Supply	V_{AGC}	V_{CC}	Vdc
Input Differential Voltage	V_{ID}	5.0	Vdc
Operating Temperature Range	T_A	-40 to $+85$	$^\circ\text{C}$
Storage Temperature Range	T_{stg}	-65 to $+150$	$^\circ\text{C}$
Junction Temperature	T_J	+150	$^\circ\text{C}$

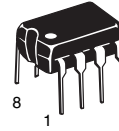
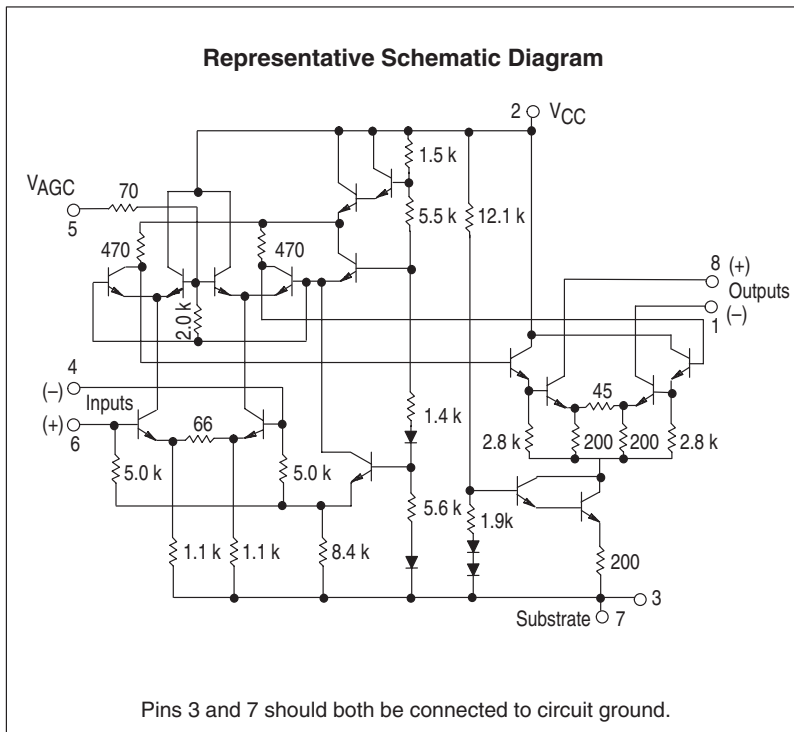

P DIP 8 = PP
 PLASTIC PACKAGE
 CASE 626

CROSS REFERENCE/ORDERING INFORMATION

PACKAGE	MOTOROLA	LANSDALE
P DIP 8	MC1490P	ML1490PP

Note: Lansdale lead free (Pb) product, as it becomes available, will be identified by a part number prefix change from ML to MLE.

PIN CONNECTIONS

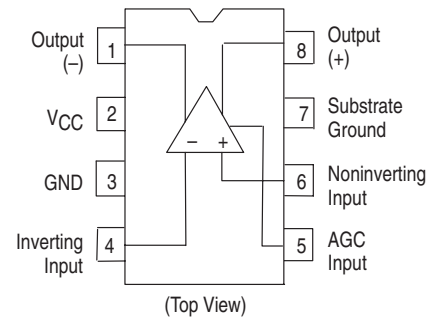

SCATTERING PARAMETERS

($V_{CC} = +12$ Vdc, $T_A = +25^\circ\text{C}$, $Z_0 = 50 \Omega$)

Parameter	Symbol	f = MHz		Unit
		30	60	
Input Reflection Coefficient	$ S_{11} $ θ_{11}	0.95 -7.3	0.93 -16	- deg
Output Reflection Coefficient	$ S_{22} $ θ_{22}	0.99 -3.0	0.98 -5.5	- deg
Forward Transmission Coefficient	$ S_{21} $ θ_{21}	16.8 128	14.7 64.3	- deg
Reverse Transmission Coefficient	S_{12} θ_{12}	0.00048 84.9	0.00092 79.2	- deg

ELECTRICAL CHARACTERISTICS ($V_{CC} = 12 \text{ Vdc}$, $f = 60 \text{ MHz}$, $BW = 1.0 \text{ MHz}$, $T_A = 25^\circ\text{C}$)

Characteristic	Figure	Symbol	Min	Typ	Max	Unit
Power Supply Current Drain	–	I_{CC}	–	–	17	mA
AGC Range (AGC) 5.0 V Min to 7.0 V Max	19	M_{AGC}	–60	–	–	dB
Output Stage Current (Sum of Pins 1 and 8)	–	I_O	4.0	–	7.5	mA
Single-Ended Power Gain $R_S = R_L = 50 \Omega$	19	G_P	40	–	–	dB
Noise Figure $R_S = 50 \text{ Ohms}$	19	NF	–	6.0	–	dB
Power Dissipation	–	P_D	–	168	204	mW

Figure 1. Unneutralized Power Gain versus Frequency (Tuned Amplifier, See Figure 19)

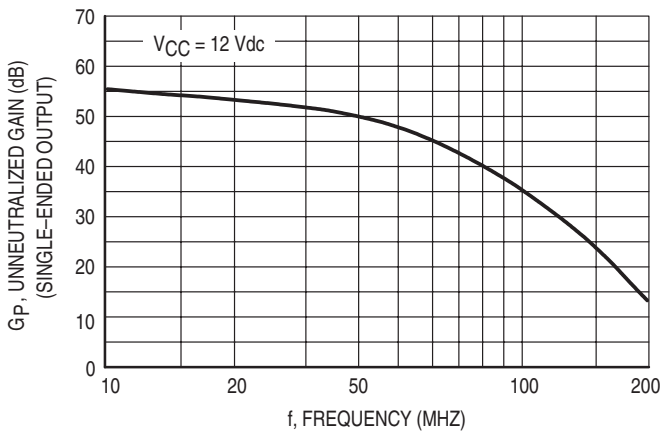

Figure 2. Voltage Gain versus Frequency (Video Amplifier, See Figure 20)

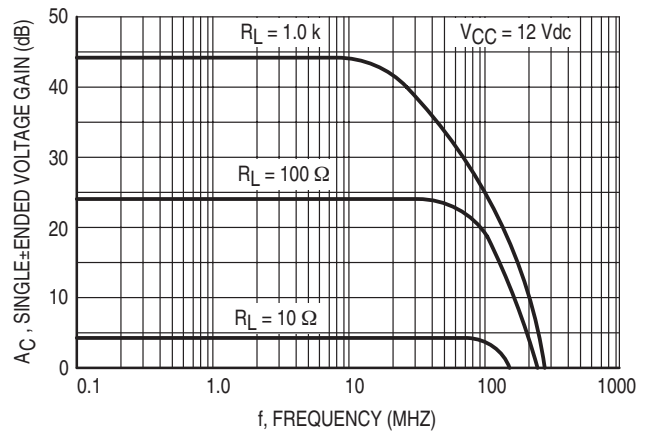

Figure 3. Dynamic Range: Output Voltage versus Input Voltage (Video Amplifier, See Figure 20)

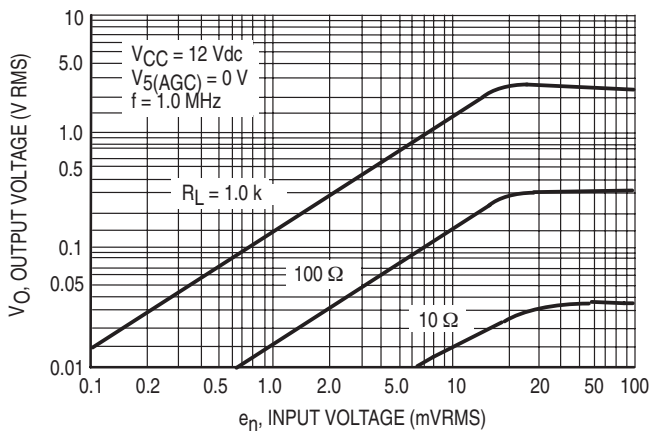
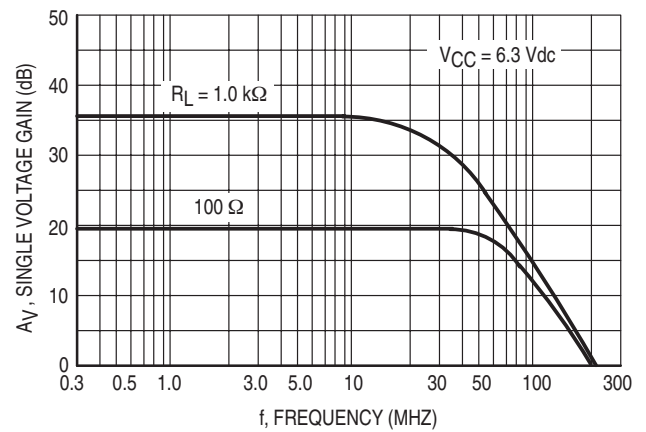

Figure 4. Voltage Gain versus Frequency (Video Amplifier, See Figure 20)



Legacy Applications Information

Figure 5. Voltage Gain and Supply Current versus Supply Voltage (Video Amplifier, See Figure 20)

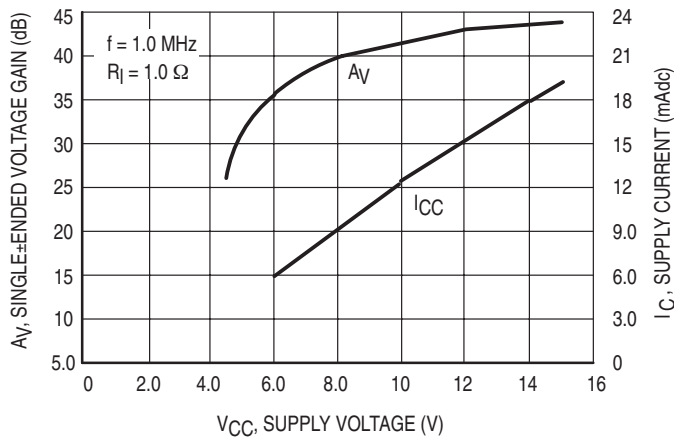

Figure 6. Typical Gain Reduction versus AGC Voltage

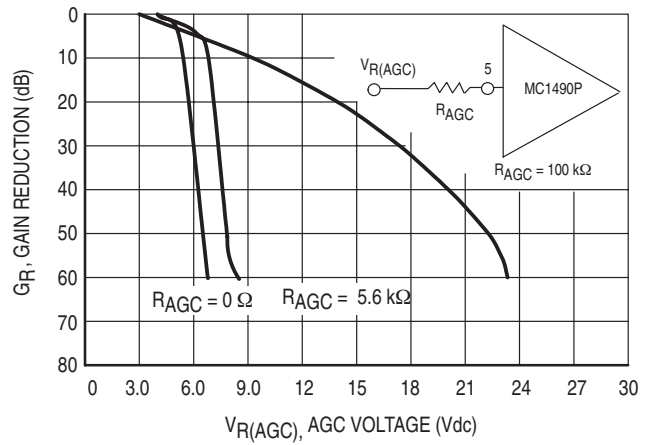

Figure 7. Typical Gain Reduction versus AGC Current

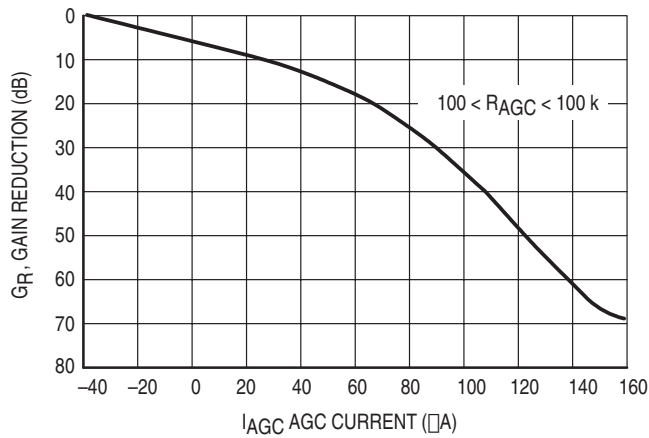

Figure 8. Fixed Tuned Power Gain Reduction versus Temperature (See Test Circuit, Figure 19)

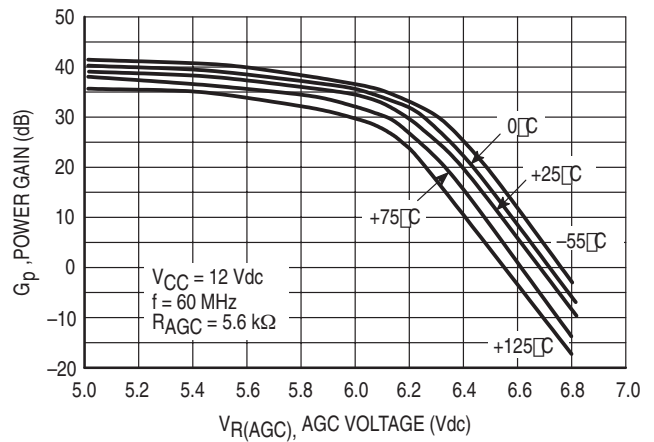

Figure 9. Power Gain versus Supply Voltage (See Test Circuit, Figure 19)

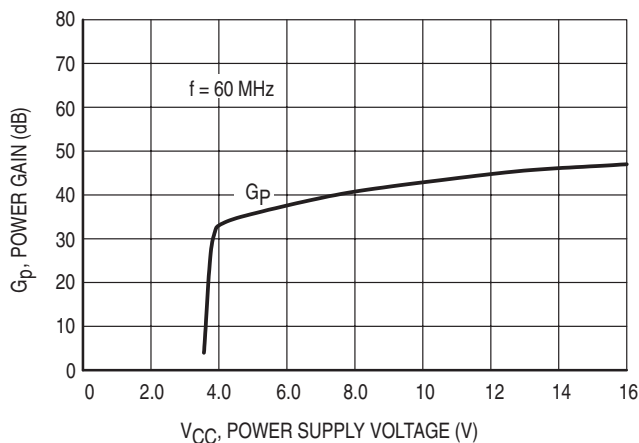
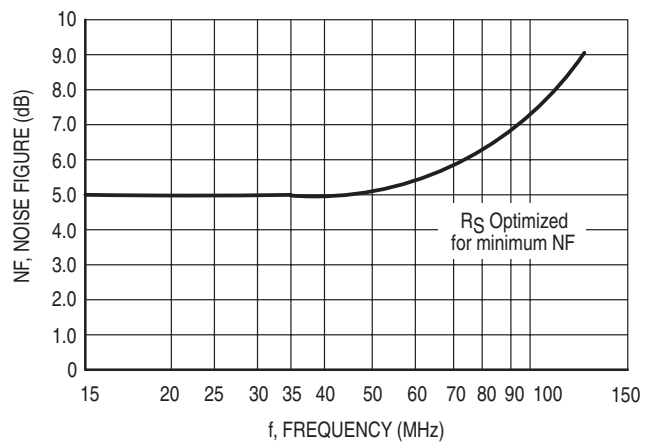

Figure 10. Noise Figure versus Frequency



Legacy Applications Information

Figure 11. Noise Figure versus Source Resistance

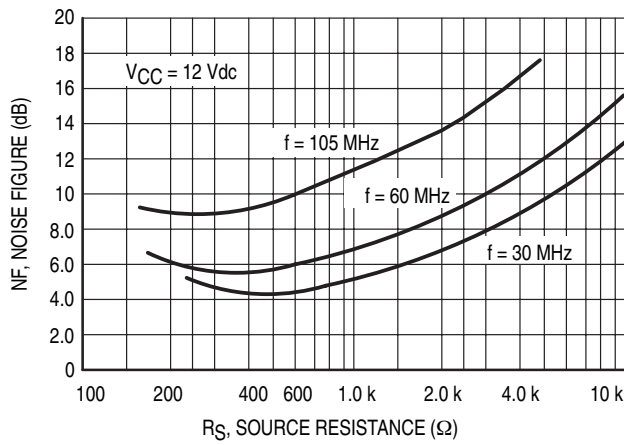

Figure 12. Noise Figure versus AGC Gain Reduction

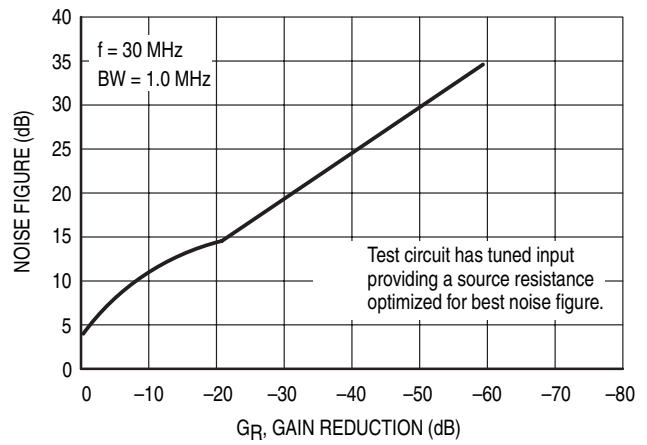

Figure 13. Harmonic Distortion versus AGC Gain Reduction for AM Carrier (For Test Circuit, See Figure 14)

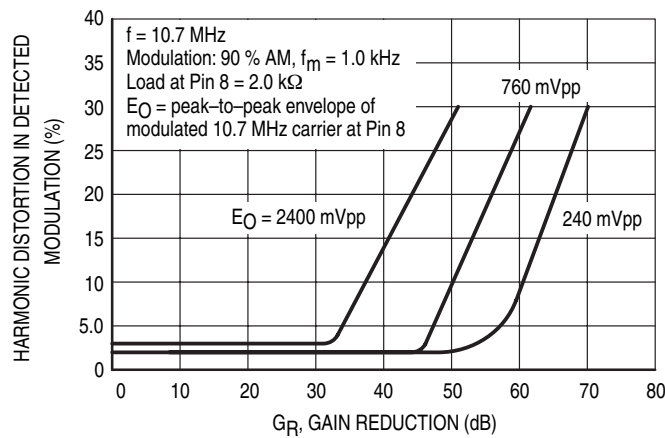
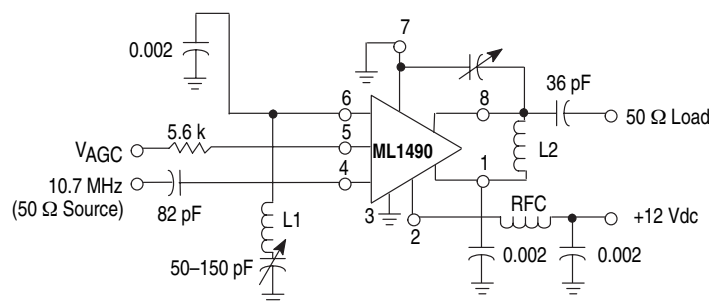

Figure 14. 10.7 MHz Amplifier Gain 55 dB, BW 100 kHz



L1 = 24 turns, #22 AWG wire on a T12-44 micro metal Toroid core (-124 pF)

L2 = 20 turns, #22 AWG wire on a T12-44 micro metal Toroid core (-100 pF)

Legacy Applications Information

Figure 15. S_{11} and S_{22} , Input and Output Reflection Coefficient

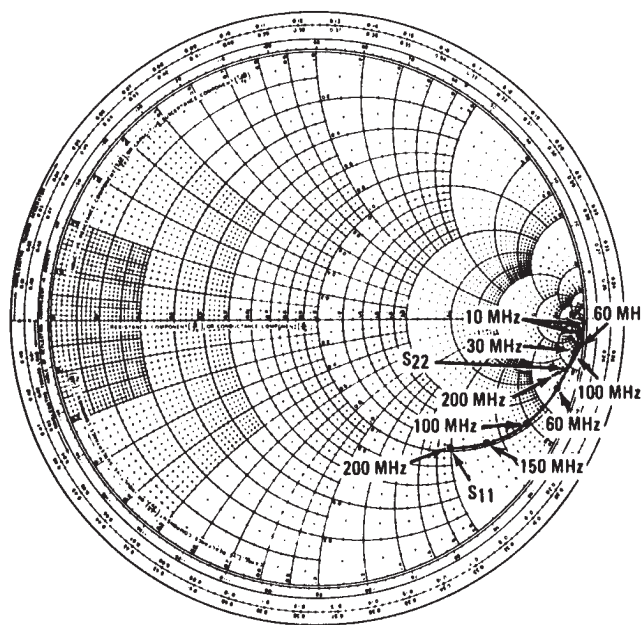

Figure 16. S_{11} and S_{22} , Input and Output Reflection Coefficient

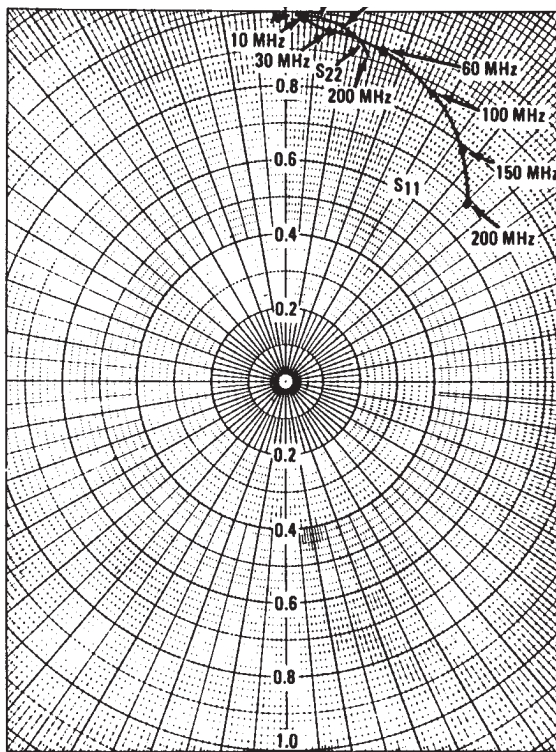

Figure 17. S_{21} , Forward Transmission Coefficient (Gain)

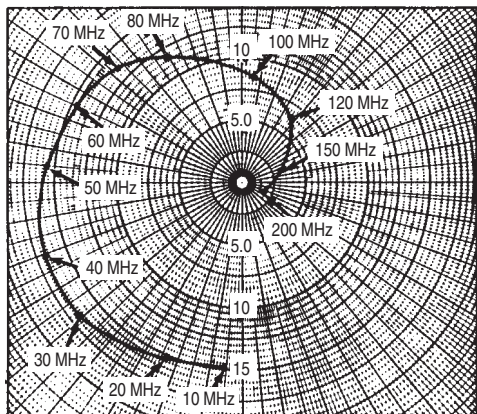
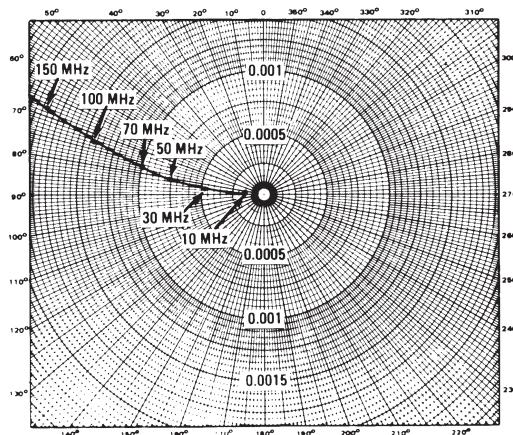
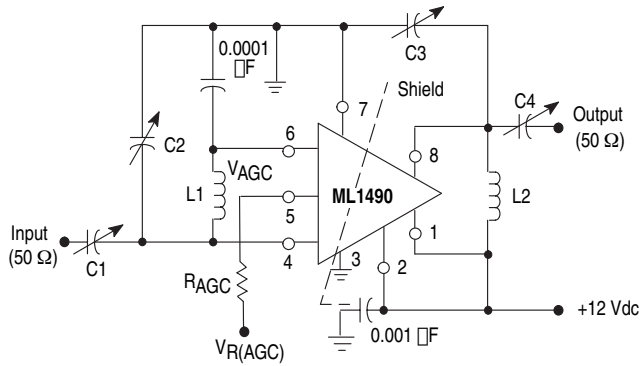

Figure 18. S_{12} , Reverse Transmission Coefficient (Feedback)



Legacy Applications Information

Figure 19. 60 MHz Power Gain Test Circuit



L1 = 7 turns, #20 AWG wire, 5/16" Dia., 5/8" long
 L2 = 6 turns, #14 AWG wire, 9/16" Dia., 3/4" long
 C1, C2, C3 = (1-30) pF
 C4 = (1-10) pF

Figure 20. Video Amplifier

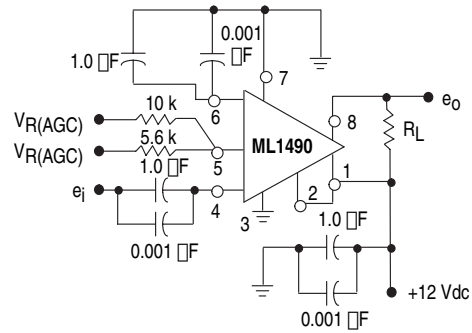
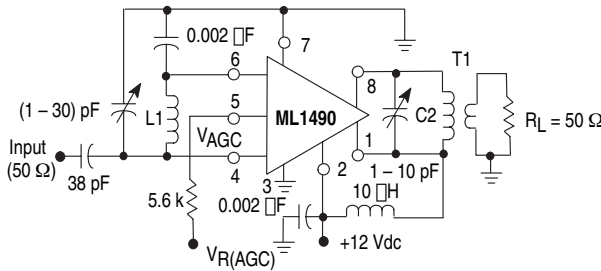
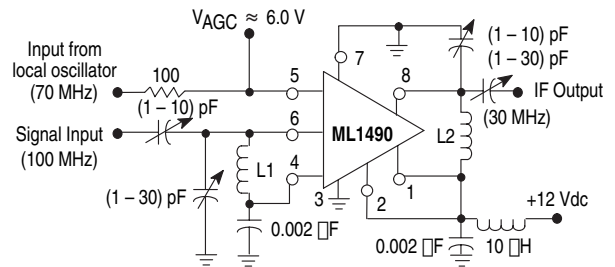

Figure 21. 30 MHz Amplifier
 (Power Gain = 50 dB, BW 1.0 MHz)



L1 = 12 turns, #22 AWG wire on a Toroid core, (T37-6 micro metal or equiv).
 T1: Primary = 17 turns, #20 AWG wire on a Toroid core, (T44-6).
 Secondary = 2 turns, #20 AWG wire.

Figure 22. 100 MHz Mixer



L1 = 5 turns, #16 AWG wire, 1/4", ID Dia., 5/8" long
 L2 = 16 turns, #20 AWG wire on a Toroid core, (T44-6).

Figure 23. Two-Stage 60 MHz IF Amplifier (Power Gain 80 dB, BW 1.5 MHz)

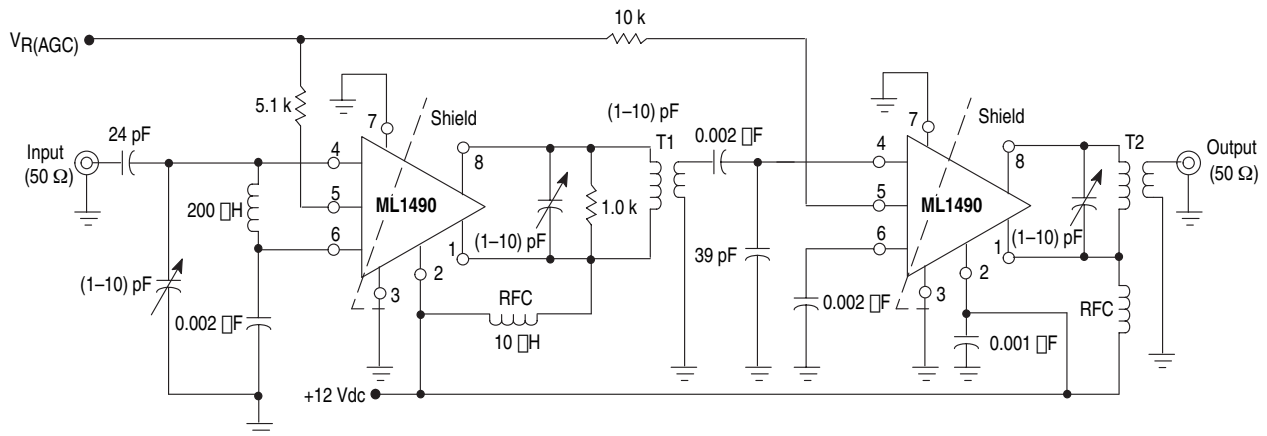

T1: Primary Winding = 15 turns, #22 AWG wire, 1/4" ID Air Core
 Secondary Winding = 4 turns, #22 AWG wire,
 Coefficient of Coupling ≈ 1.0

T2: Primary Winding = 10 turns, #22 AWG wire, 1/4" ID Air Core
 Secondary Winding = 2 turns, #22 AWG wire,
 Coefficient of Coupling ≈ 1.0

DESCRIPTION OF SPEECH COMPRESSOR

The amplifier drives the base of a PNP transistor operating common-emitter with a voltage gain of approximately 20. The control R1 varies the quiescent Q point of this transistor so that varying amounts of signal exceed the level V_T . Diode D1 rectifies the positive peaks of Q1's output only when these peaks are greater than $V_T \approx 7.0$ V. The resulting output is filtered by C_X , R_X .

R_X controls the charging time constant or attack time. C_X is involved in both charge and discharge. R2 (the 150 k Ω and input resistance of the emitter-follower Q2) controls the decay time. Making the decay long and attack short is accomplished by making R_X small and R2 large. (A Darlington emitter-follower may be needed if extremely slow decay times are required.)

The emitter-follower Q2 drives the AGC Pin 5 of the ML1490PP and reduces the gain. R3 controls the slope of signal compression.

Table 1. Distortion versus Frequency

Frequency	Distortion		Distortion	
	10 mV e_i	100 mV e_i	10 mV e_i	100 mV e_i
100 Hz	3.5%	12%	15%	27%
300 Hz	2%	10%	6%	20%
1.0 kHz	1.5%	8%	3%	9%
10 kHz	1.5%	8%	1%	3%
100 kHz	1.5%	8%	1%	3%
	Notes 1 and 2		Notes 3 and 4	

- Notes:** (1) Decay = 300 ms
Attack = 20 ms
(2) $C_X = 7.5 \mu\text{F}$
 $R_X = 0$ (Short)
- (3) Decay = 20 ms
Attack = 3.0 ms
(4) $C_X = 0.68 \mu\text{F}$
 $R_X = 1.5 \text{ k}\Omega$

Figure 24. Speech Compressor

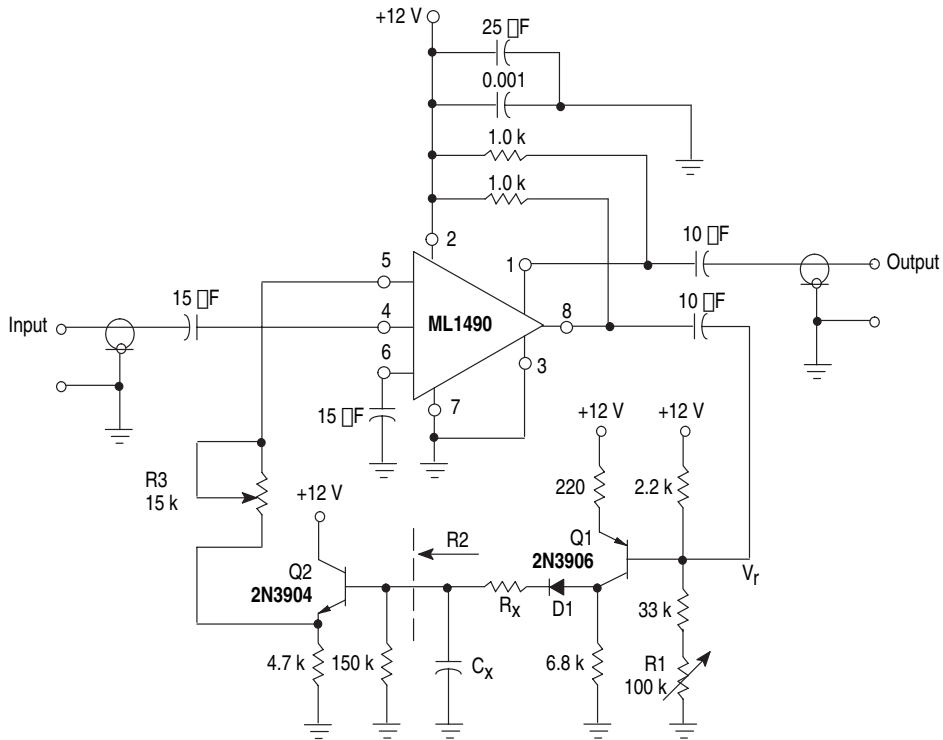

OUTLINE DIMENSIONS

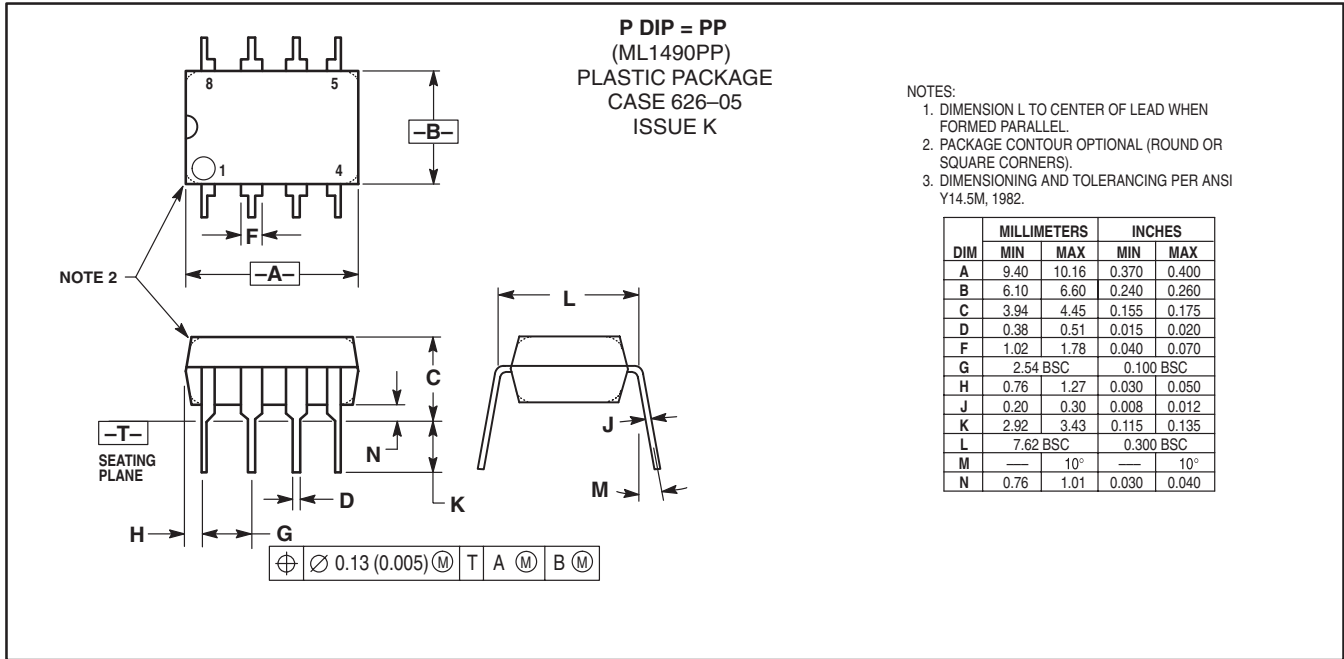

Lansdale Semiconductor reserves the right to make changes without further notice to any products herein to improve reliability, function or design. Lansdale does not assume any liability arising out of the application or use of any product or circuit described herein; neither does it convey any license under its patent rights nor the rights of others. "Typical" parameters which may be provided in Lansdale data sheets and/or specifications can vary in different applications, and actual performance may vary over time. All operating parameters, including "Typicals" must be validated for each customer application by the customer's technical experts. Lansdale Semiconductor is a registered trademark of Lansdale Semiconductor, Inc.