

Feb.1.2023 Copyright 2023 HIROSE ELECTRIC CO., LTD. All Rights Reserved.  
In case of consideration for using Automotive equipment / device which demand high reliability, kindly contact our sales window correspondents.

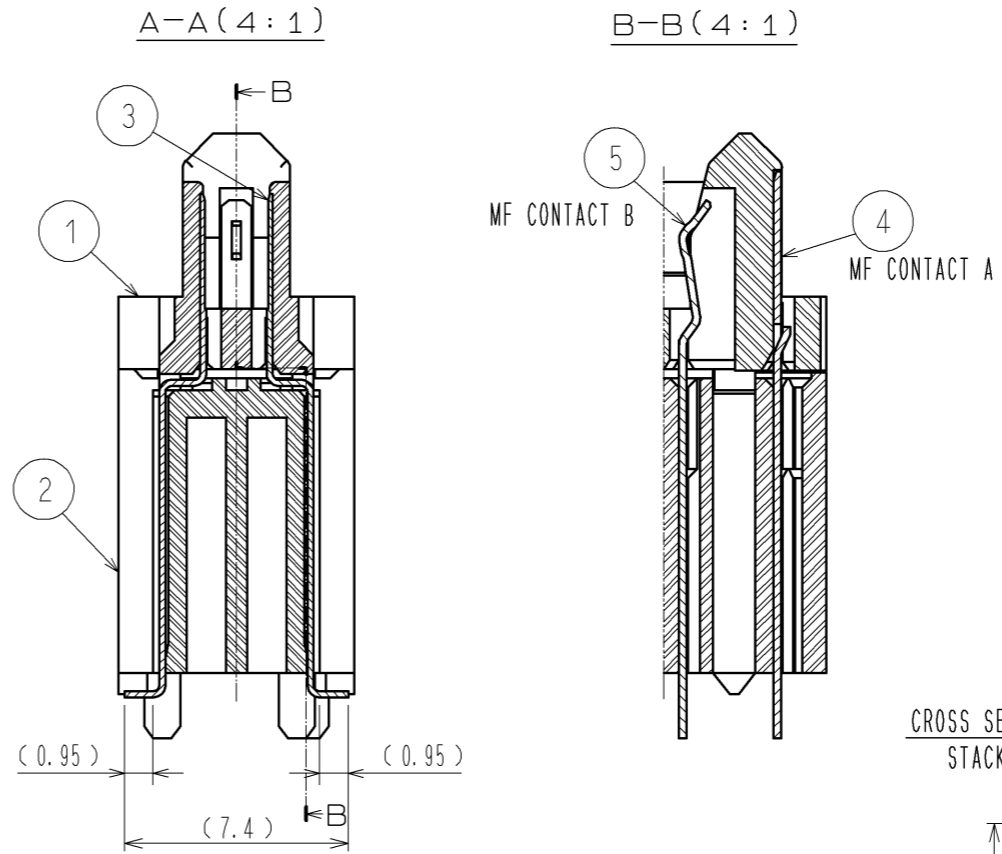

CROSS SECTION OF MATING(FREE)  
STACKING HEIGHT=25mm  
FX18-60S-0.8SV15

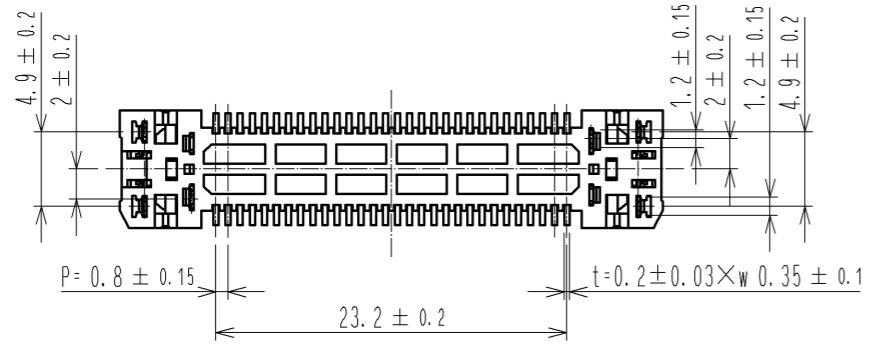
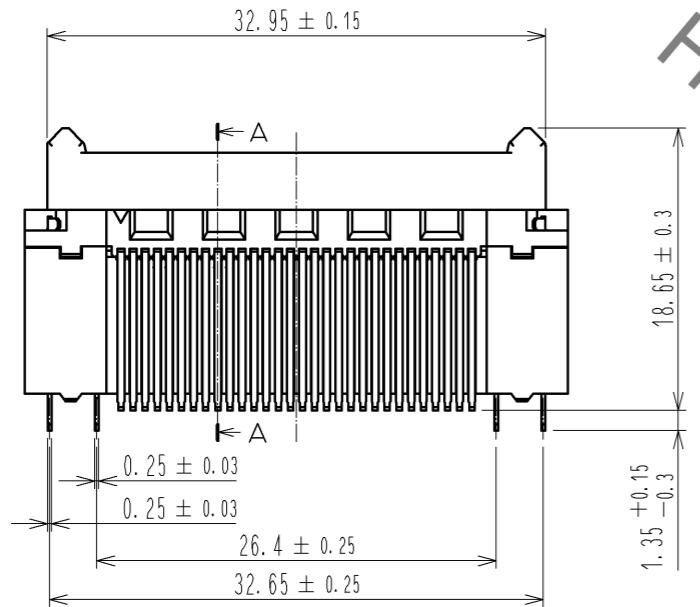
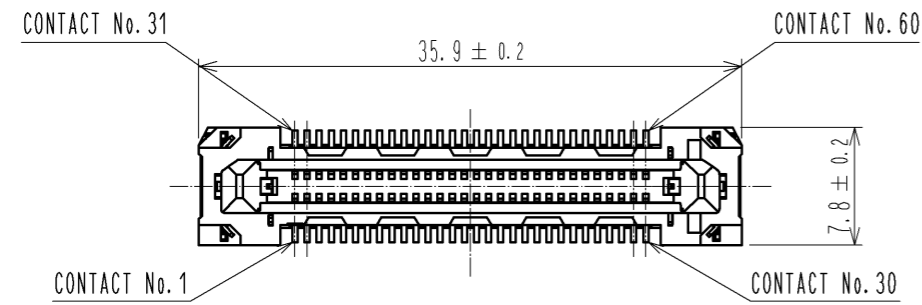
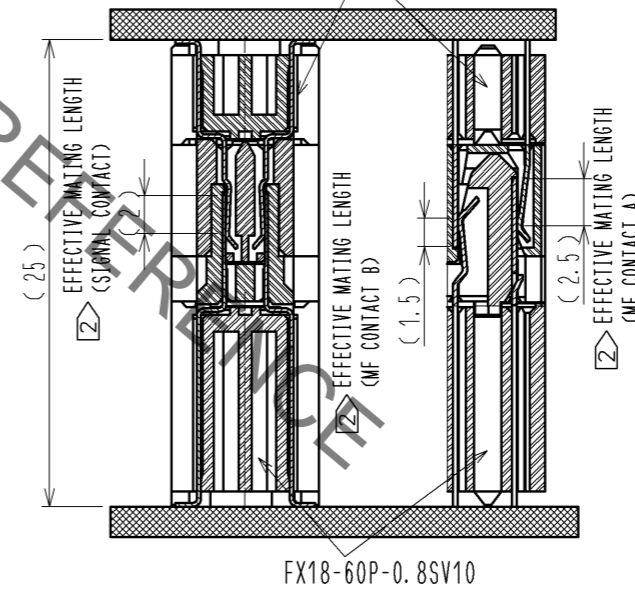

CROSS SECTION OF MATING(FREE)  
STACKING HEIGHT=30mm  
FX18-60S-0.8SV20

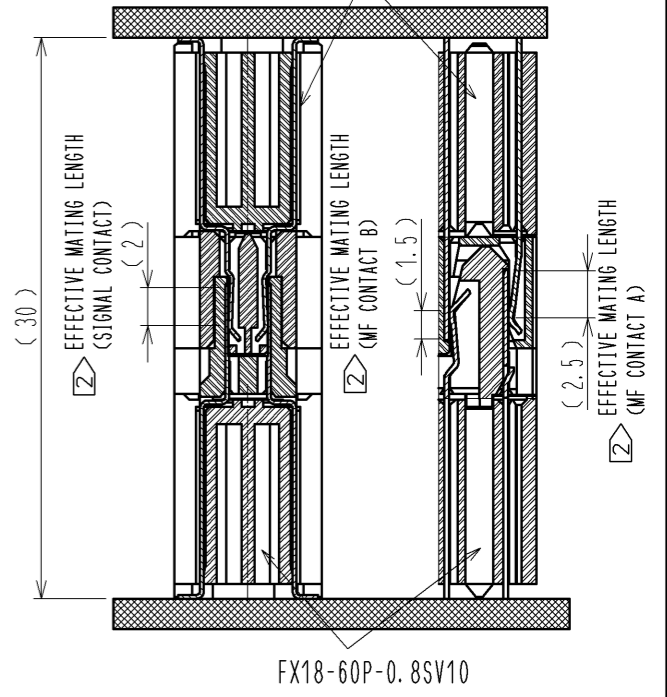

- NOTE 1 LEAD CO-PLANARITY IS 0.1mm MAX.
- ② CONTACTS ARE 3 STEPS SEQUENTIAL. (MF CONTACT A->SIGNAL CONTACT->MF CONTACT B) WHEN USING THIS SEQUENTIAL STRUCTURE, PLEASE AVOID ANGLED INSERTION.
  - ③ MF CONTACT A AND MF CONTACT B CAN BE USED AS POWER SUPPLY CONTACT. (3A/PIN MAX)
  - ④ IT SHOWS THE VACUUM PICKUP AREA. (SEE PAGE 2)  
REMOVE THE MYLAR TAPE BEFORE MATING CONNECTORS.
  - ⑤ THIS IS PACKAGED IN TRAY. (60pcs/TRAY)
  - ⑥ BLEMISH AND HIT MARK CAN BE OCCURED THROUGH OUT THE MANUFACTURING PROCESS WHICH DOESN' T AFFECT QUALITY LEVEL.
  - ⑦ THE DIMENSIONS IN PARENTHESES ARE FOR REFERENCES.

3	PHOSPHOR BRONZE	CONTACT AREA:GOLD 0.1 μm LEAD AREA:GOLD 0.03 μm UNDER PLATING:NICKEL 1.3 μm	5	COPPER ALLOY	CONTACT AREA:GOLD 0.1 μm LEAD AREA:TIN-PLATING 1 μm UNDER PLATING:NICKEL 1.3 μm
2	POLYAMIDE	BLACK UL94V-0	4	COPPER ALLOY	CONTACT AREA:GOLD 0.1 μm LEAD AREA:TIN-PLATING 1 μm UNDER PLATING:NICKEL 1.3 μm
1	POLYAMIDE	BLACK UL94V-0			
NO.	MATERIAL	FINISH . REMARKS	NO.	MATERIAL	FINISH . REMARKS

UNITS mm		SCALE 2 : 1	COUNT △	DESCRIPTION OF REVISIONS	DESIGNED	CHECKED	DATE
APPROVED : HS. OKAWA 11.08.24				DRAWING NO.	EDC3-334383-00		
CHECKED : KI. HIROKAWA 11.08.24				PART NO.	FX18-60P-0.8SV10		
DESIGNED : TH. SANO 11.08.24				CODE NO.	CL579-0023-5-00		
DRAWN : TH. SANO 11.08.24					1/2		

Feb.1.2023 Copyright 2023 HIROSE ELECTRIC CO., LTD. All Rights Reserved.  
 In case of consideration for using Automotive equipment / device which demand high reliability, kindly contact our sales window correspondents.

RECOMMENDED LAND PATTERN DIMENSION OF PCB(2:1)  
 (PCB THICKNESS:t=1.6mm METAL MASK THICKNESS:t=0.12mm)

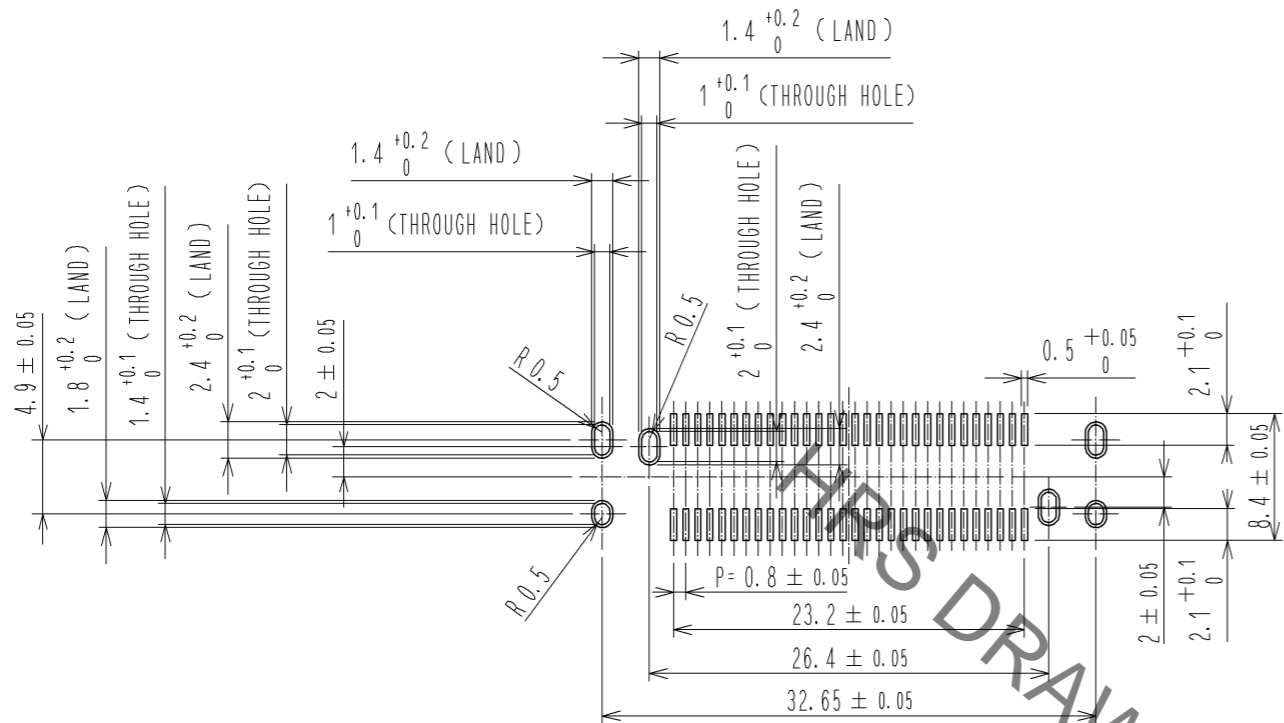

5 DRAWING FOR PACKING(1:2)

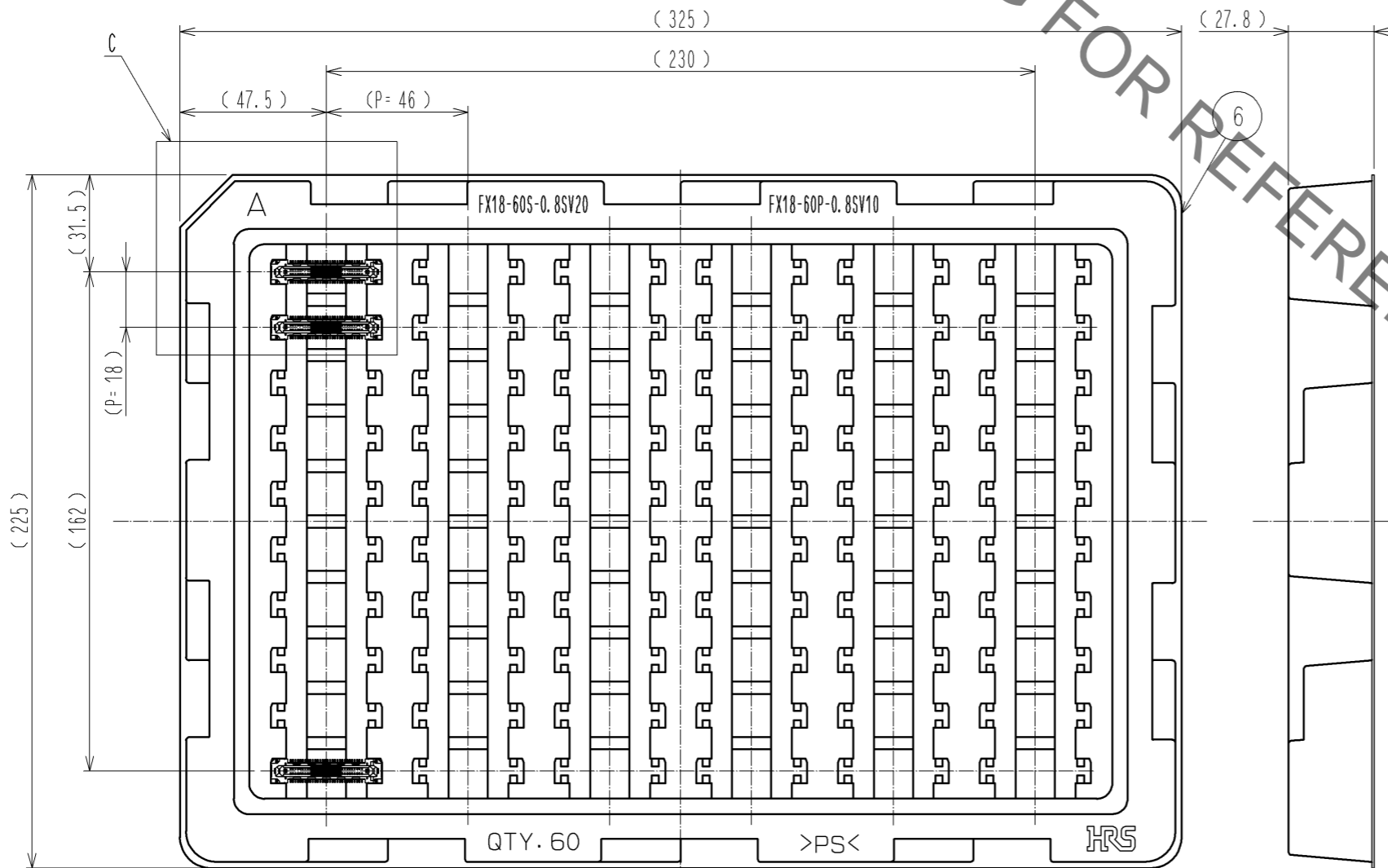

8 CONFIGURATION OF MF CONTACT A

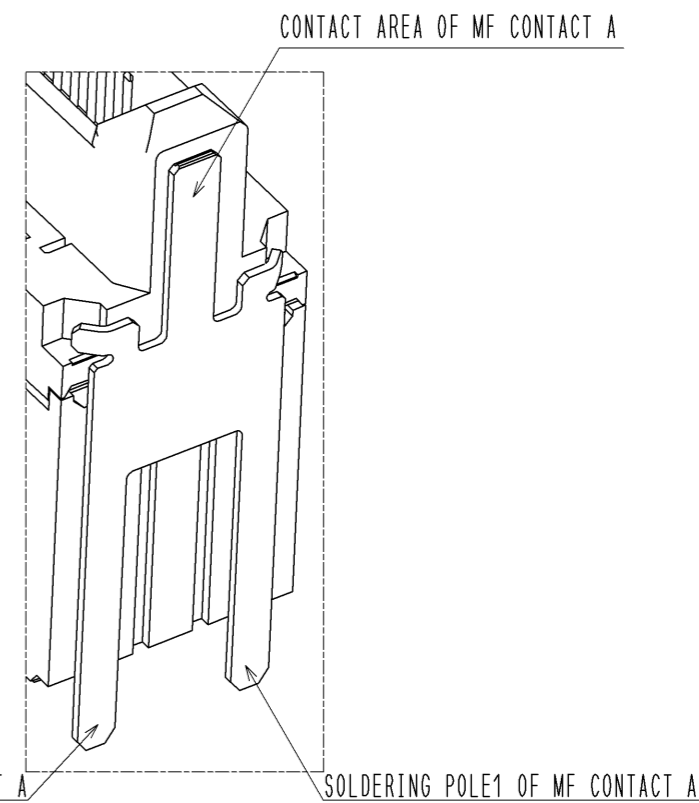

NOTE 8 SOLDERING LEAD OF MF CONTACT A SPLITS INTO TWO POLES.  
 BE SURE TO CONNECT TO THE SAME CIRCUIT.

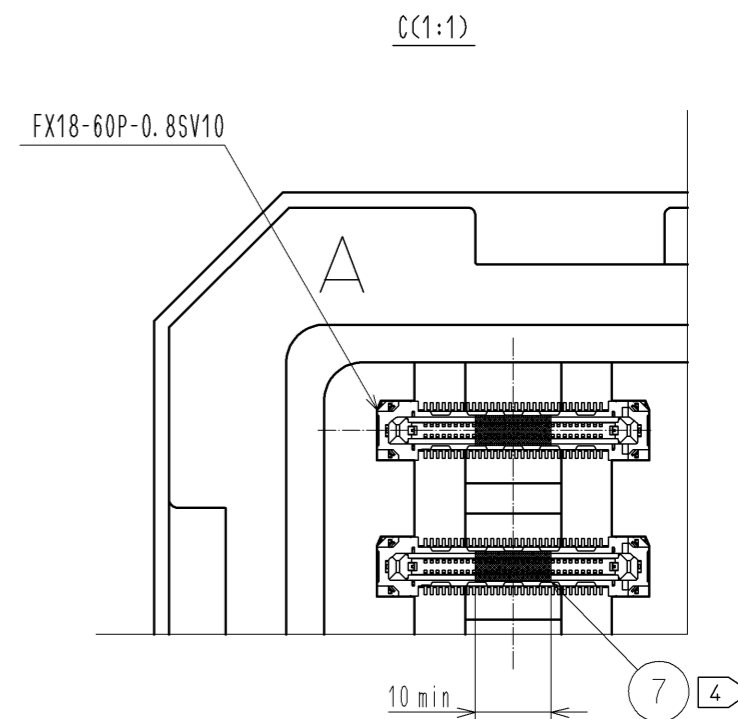

<b>HRS</b>	DRAWING NO.	EDC3-334383-00	2/2
	PART NO.	FX18-60P-0.8SV10	
	CODE NO.	CL579-0023-5-00	