

ASMT-YTB7-0AA02

Tricolor PLCC6 Black Surface Mount LED



Data Sheet



Lead (Pb) Free
RoHS 6 fully
compliant



Description

This family of SMT LEDs packaged in the form of PLCC-6 with separate heat path for each LED dice, enabling it to be driven at higher current.

For easy pick & place, the LEDs are shipped in EIA-compliant tape and reel. Every reel is shipped from a single intensity and color bin; except red color for better uniformity.

These LEDs are compatible with reflow soldering process.

This super wide viewing angle at 120° together with the built in reflector pushing up the intensity of the light output makes these LED suitable to be used in the interior electronics signs.

The black top surface of the LED provides better contrast enhancement especially in the full color sign application.

Features

- Standard PLCC-6 package (Plastic Leaded Chip Carrier) with individual addressable pin-out for higher flexibility of driving configuration
- LED package with diffused silicone encapsulation
- Using AlInGaP and InGaN dice technologies
- Wide viewing angle at 120°
- Compatible with reflow soldering process
- JEDEC MSL 3
- Water-Resistance (IPX6*) per IEC 60529:2001
 - The test is conducted on component level by mounting the components on PCB with proper potting to protect the leads. It is strongly recommended that customers perform necessary tests on the components for their final application

Applications

- Indoor and outdoor full color display

CAUTION: These LEDs are Class 1C ESD sensitive. Please observe appropriate precautions during handling and processing. Please refer to Avago Application Note AN-1142 for additional details.

CAUTION: Customer is advised to keep the LED in the MBB when not in use as prolonged exposure to environment might cause the silver plated leads to tarnish, which might cause difficulties in soldering.

Package Dimensions

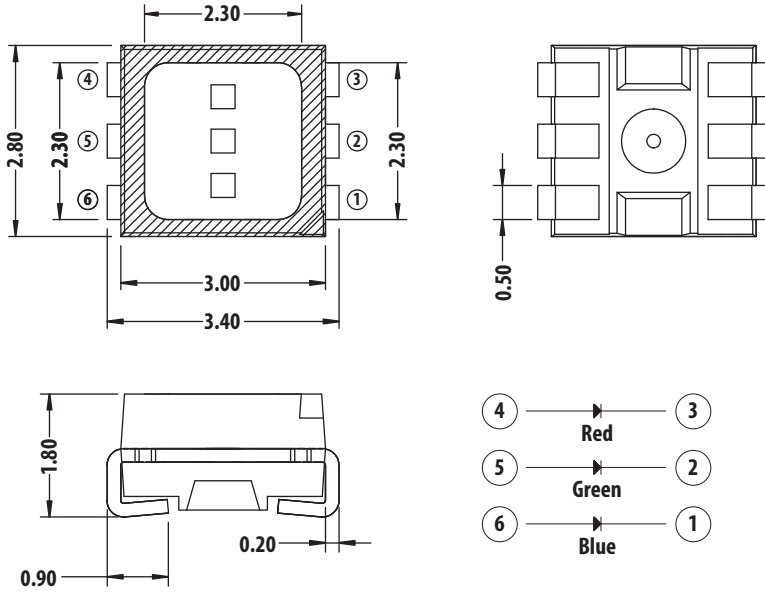

Lead Configuration

1	Cathode	Blue
2	Cathode	Green
3	Cathode	Red
4	Anode	Red
5	Anode	Green
6	Anode	Blue

Notes:

1. All Dimensions are in millimeters
2. Tolerance = ± 0.2 mm unless otherwise specified
3. Terminal Finish: Ag plating
4. Encapsulention material: silicone resin

Table 1. Device Selection Guide

Part Number	Color 1 - Red			Color 2 - Green			Color 3 - Blue					
	Bin ID	Min. I_v @20mA (mcd)	Typ. I_v @20mA (mcd)	Max I_v @ 20mA (mcd)	Bin ID	Min. I_v @ 20mA (mcd)	Typ. I_v @ 20mA (mcd)	Max I_v @ 20mA (mcd)	Bin ID	Min. I_v @ 20mA (mcd)	Typ. I_v @ 20mA (mcd)	Max I_v @ 20mA (mcd)
ASMT-YTB7-0AA02	U2	560	650	1125	W2	1400	1900	2850	T1	285	384	560

Notes:

1. The luminous intensity I_v is measured at the mechanical axis of the LED package and it is tested in pulsing condition. The actual peak of the spatial radiation pattern may not be aligned with this axis.
2. Tolerance = $\pm 12\%$

Part Numbering System

ASMT - Y T B7 - 0 X₂ X₃ X₄ X₅

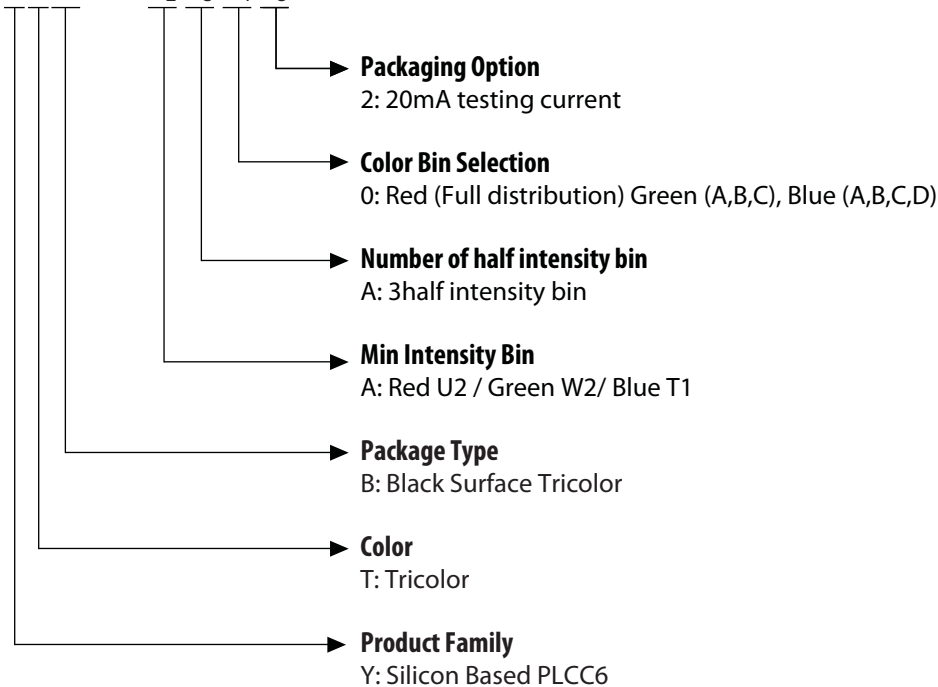

Table 2. Absolute Maximum Ratings (T_A = 25°C)

Parameter	Red	Green & Blue	Unit
DC forward current [1]	50	25	mA
Peak forward current [2]	100	100	mA
Power dissipation	125	90	mW
Maximum junction temperature T _J max	110		°C
Operating temperature range	- 40 to + 100 [3]		°C
Storage temperature range	- 40 to + 100		°C

Note:

1. Derate linearly as shown in Figure 4a & 4b
2. Duty Factor = 10% Frequency = 1KHz
3. Refer to Figure 4a and Figure 4b for more information

Table 3. Optical Characteristics (T_A = 25°C)

Color	Luminous Intensity, I _v , mcd [1]			Dominant Wavelength, λ _d (nm) [2]			Peak Wavelength, λ _p (nm)	Viewing Angle 2θ _{1/2} (°) [3]	Test Current (mA)
	Min	Typ	Max.	Min	Typ	Max	Typ.	Typ	
Red	560	650	1125	617	623	627	630	120	20
Green	1400	1900	2850	525	529	537	522	120	20
Blue	285	384	560	465	469	475	465	120	20

Notes:

1. The luminous intensity I_v is measured at the mechanical axis of LED package and it is tested in pulsing condition. The actual peak of the spatial radiation pattern may not be aligned with the axis.
2. The dominant wavelength is derived from the CIE Chromaticity Diagram and represents the perceived color of the device.
3. θ_{1/2} is the off axis angle where the luminous intensity is 1/2 the peak intensity

Table 4. Electrical Characteristics (T_A = 25°C)

Color	Forward Voltage, V _F (V) [1]			Reverse Voltage V _R @100μA [3]	Reverse Voltage V _R @10μA [3]	Thermal Resistance Rθ _{J-P} (°C/W) [2]	Test Current (mA)
	Min	Typ.	Max.	Min	Min	Typ	
Red	1.80	2.10	2.50	4	-	280	20
Green	2.80	3.10	3.60	-	4	240	20
Blue	2.80	3.10	3.60	-	4	240	20

Note:

1. Tolerance ± 0.1V.
2. One chip on thermal resistance
3. Indicated product final testing condition, long term reverse bias is not recommended.

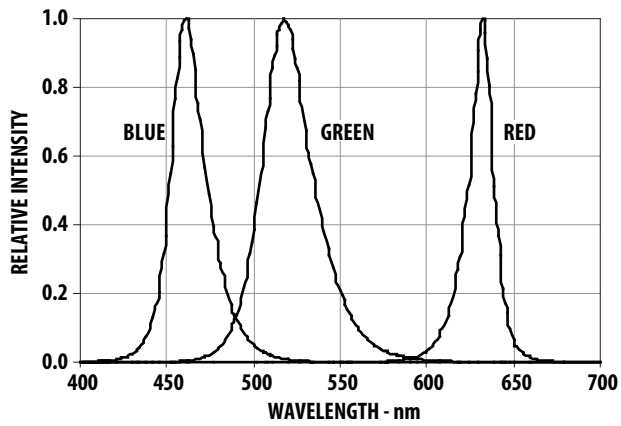

Figure 1. Relative Intensity vs Wavelength

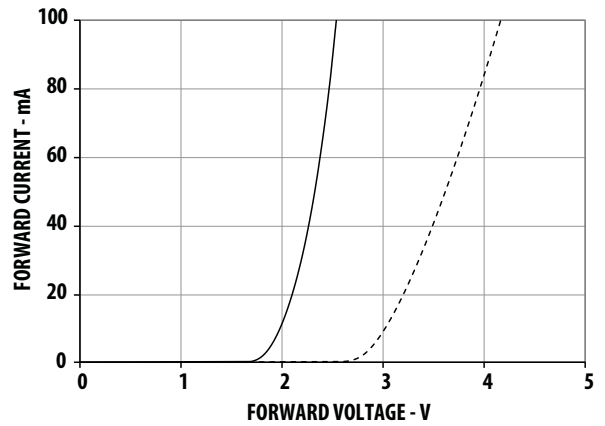

Figure 2. Forward Current - mA vs Forward Voltage

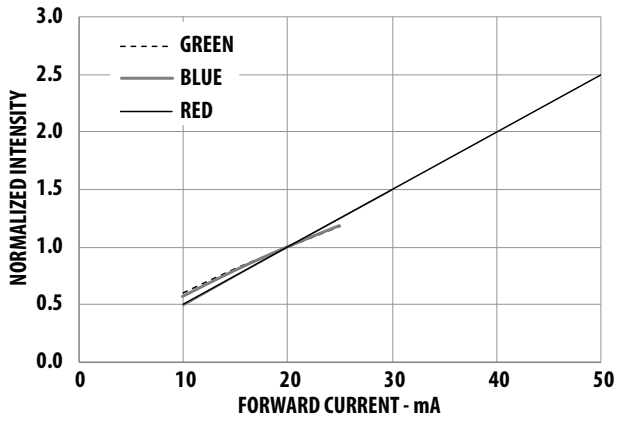

Figure 3. Relative Intensity vs Forward Current

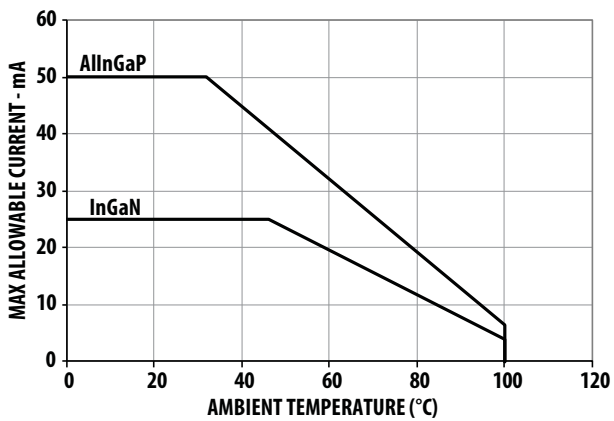

Figure 4a. Maximum forward current vs. ambient temperature. (3 chips)

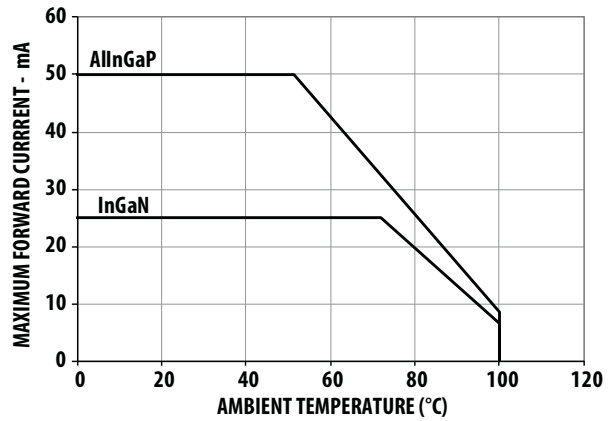

Figure 4b. Maximum forward current vs. ambient temperature. (single chip)

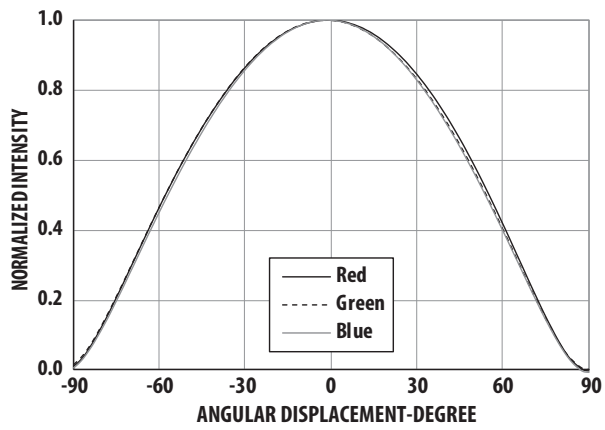

Figure 5a. Radiation Pattern for X axis

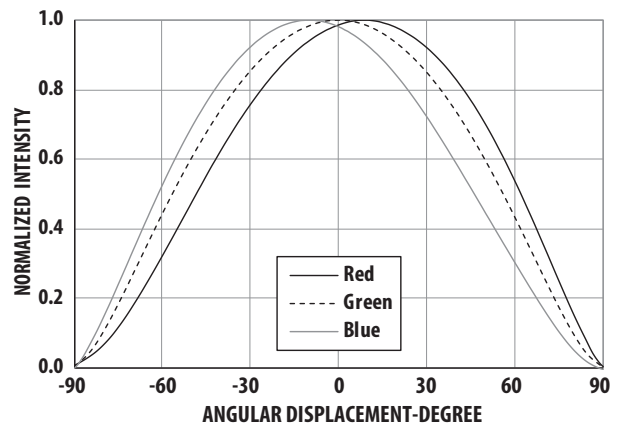

Figure 5b. Radiation Pattern for Y axis

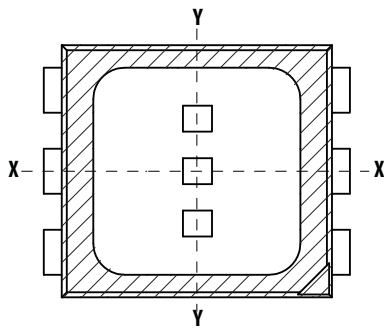

Figure 5c. Component Axis for Radiation Patterns

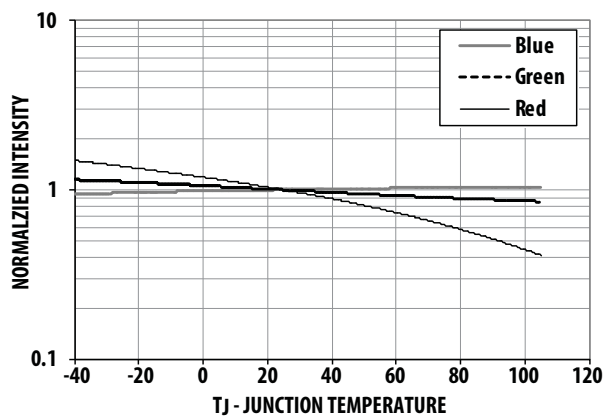

Figure 6. Relative Intensity vs Junction Temperature

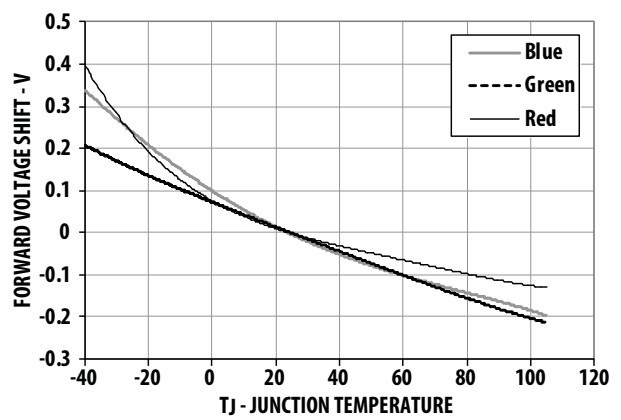

Figure 7. Forward Voltage vs Junction Temperature

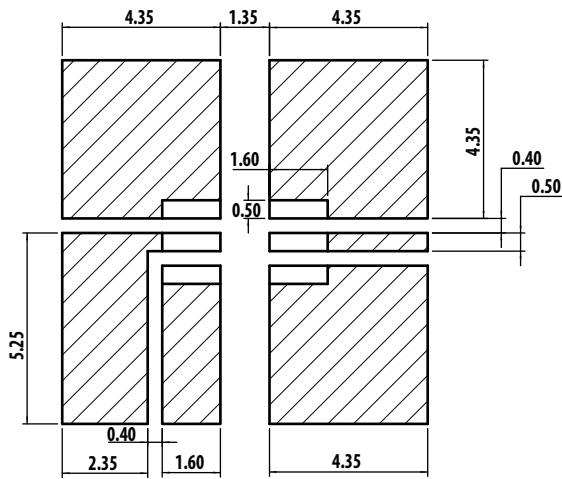

Figure 8a. Recommended soldering land pattern.

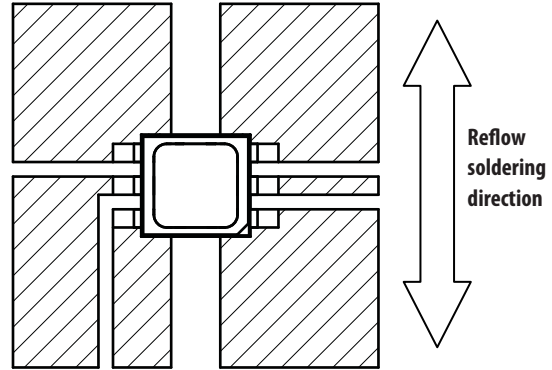
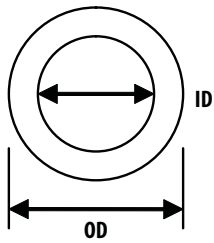

Figure 8b. LED Configuration on land pattern



ID = 1.7mm
OD = 3.5mm

Figure 9. Recommended Pick and Place Nozzle Tip

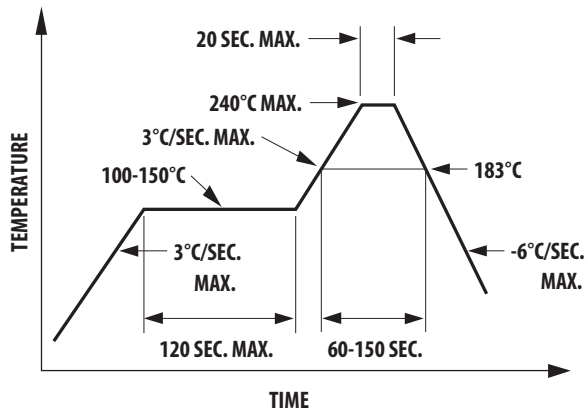

Figure 10. Recommended leaded reflow soldering profile.

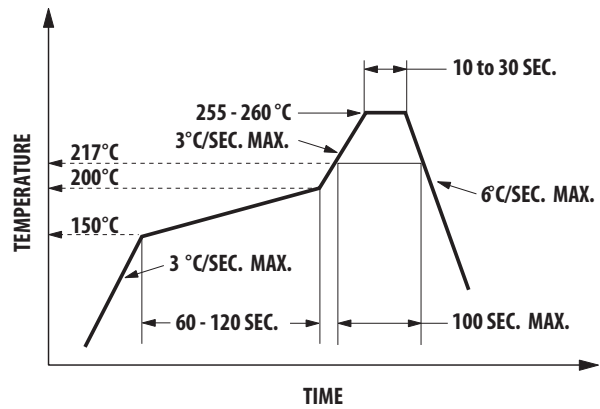

Figure 11. Recommended Pb-free reflow soldering profile.

Note: For detail information on reflow soldering of Avago surface mount LEDs, do refer to Avago Application Note AN 1060 Surface Mounting SMT LED Indicator Components

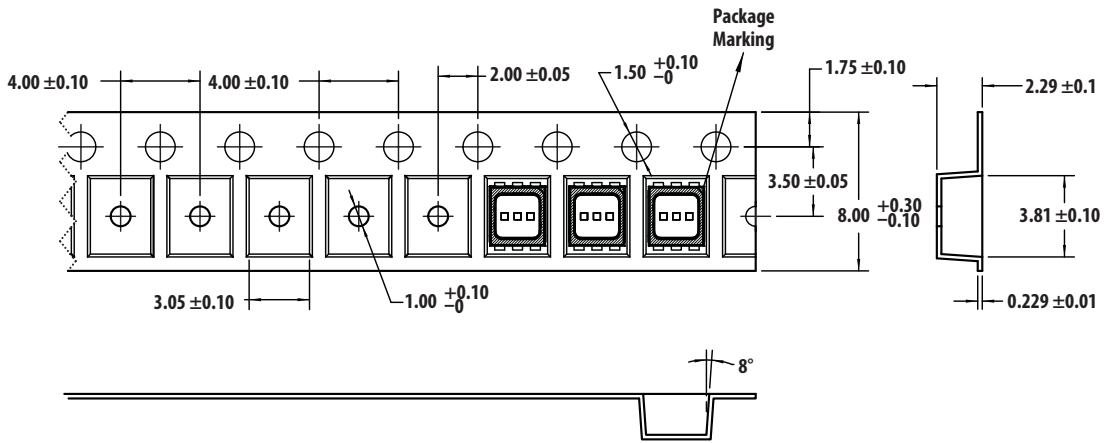

Figure 12. Carrier tape Dimension

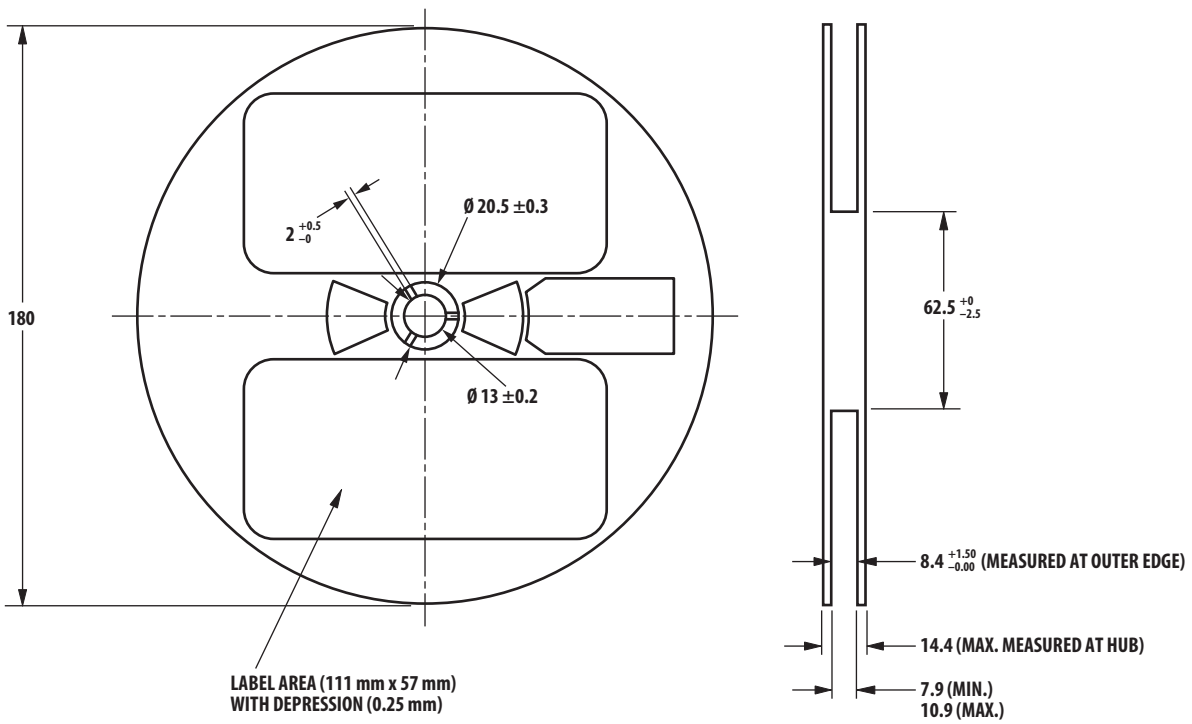

Figure 13. Reel Dimension

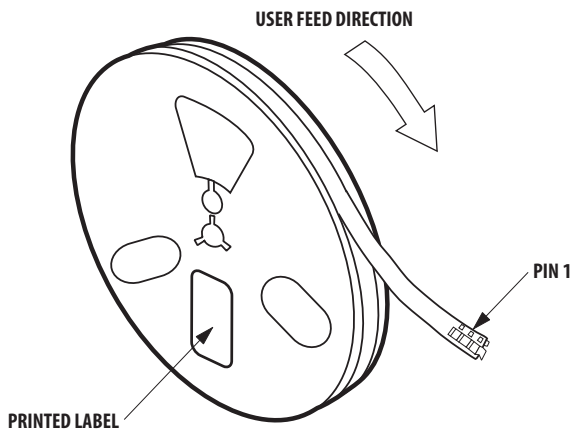

Figure 14. Reeling Orientation

Packaging Label:

(i) Avago Mother Label (Available on MBB bags)

<p>AvAGO TECHNOLOGIES STANDARD LABEL LS0002 RoHS Compliant Halogen Free e4 Max Temp 260C MSL3</p>	
<p>(1P) Item: Part Number [Barcode]</p>	<p>(Q) QTY: Quantity [Barcode]</p>
<p>(1T) Lot: Lot Number [Barcode]</p>	<p>CAT: Intensity Bin [Barcode]</p>
<p>LPN: [Barcode]</p>	<p>BIN: Color Bin [Barcode]</p>
<p>(9D) MFG Date: Manufacturing Date [Barcode]</p>	
<p>(P) Customer Item: [Barcode]</p>	
<p>(V) Vendor ID: [Barcode]</p>	<p>(9D) Date Code: Date Code [Barcode]</p>
<p>DeptID: [Barcode]</p>	<p>Made In: Country of Origin [Barcode]</p>

(ii) Avago Baby Label (Available on reel)

<p>AvAGO TECHNOLOGIES BABY LABEL COSB 001B V0.0</p>	
<p>(1P) PART #: Part Number [Barcode]</p>	<p>QUANTITY: Packing Quantity [Barcode]</p>
<p>(1T) LOT #: Lot Number [Barcode]</p>	<p>(9D): DATE CODE: [Barcode]</p>
<p>(9D)MFG DATE: Manufacturing Date [Barcode]</p>	
<p>C/O: Country of Origin [Barcode]</p>	<p>D/C: Date Code VF:</p>
<p>(1T) TAPE DATE: [Barcode]</p>	<p>CAT: INTENSITY BIN</p>
	<p>BIN: COLOR BIN</p>

Example indicates luminous Intensity information for Red, Green and Blue respectively from label:

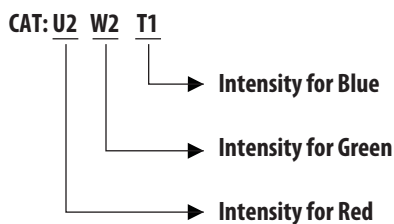

Example indicates color bin information for Green and Blue from label:

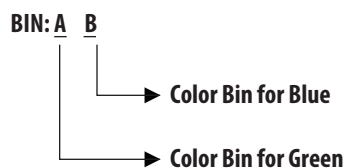

Intensity Bin Select (X₂, X₃)

Individual reel will contain parts from 1 half bin only

X ₂	Min Iv Bin (Minimum Intensity Bin)		
	Red	Green	Blue
A	U2	W2	T1

X ₃	Number of Intensity bin from X ₂		
	Red	Green	Blue
A	3	3	3

Color Bin Select (X₄)

Individual Reel will contain part from 1 full bin only

X ₄	Color Bin Combinations		
	Red	Green	Blue
0	Full distribution	A,B,C	A,B,C,D

Intensity Bin Limits

Bin ID	Min (mcd)	Max (mcd)
U2	560.0	715.0
V1	715.0	900.0
V2	900.0	1125.0
W1	1125.0	1400.0
W2	1400.0	1800.0
X1	1800.0	2240.0
X2	2240	2850

Tolerance of each bin limit $\pm 12\%$

Color Bin Limit

Red Color Bin Table

Bin ID	Dominant Wavelength		Chromaticity Coordinate			
	Min	Max	x	y	z	w
Full range	617.0	627.0	0.6850	0.3149	0.6815	0.2966
			0.7000	0.3150	0.7037	0.2962

Tolerance of each bin limit is ± 1 nm

Green Color Bin Table

Bin ID	Min Dom	Max Dom	Chromaticity Coordinate				
A	525.0	531.0	x	0.1142	0.1624	0.2001	0.1625
			y	0.8262	0.7178	0.6983	0.8012
B	528.0	534.0	x	0.1387	0.1815	0.2179	0.1854
			y	0.8148	0.7089	0.6870	0.7867
C	531.0	537.0	x	0.1625	0.2001	0.2353	0.2077
			y	0.8012	0.6983	0.6747	0.7711

Tolerance of each bin limit is ± 1 nm

Blue Color Bin Table

Bin ID	Min Dom	Max Dom	Chromaticity Coordinate				
A	465.0	469.0	x	0.1355	0.1751	0.168	0.127
			y	0.0399	0.0986	0.1094	0.053
B	467.0	471.0	x	0.1314	0.1718	0.1638	0.122
			y	0.0459	0.1034	0.1167	0.063
C	469.0	473.0	x	0.1267	0.168	0.1593	0.116
			y	0.0534	0.1094	0.1255	0.074
D	471.0	475.0	x	0.1215	0.1638	0.1543	0.1096
			y	0.0626	0.1167	0.1361	0.0868

Tolerance of each bin limit is ± 1 nm

Handling Precaution

The encapsulation material of the LED is made of silicone for better product reliability. Since silicone is a soft material, avoid pressing on the silicon or poking the silicon with a sharp object as the product could be damaged and cause premature failure. During assembly handling, the unit should be held by the body only. Please refer to Avago Application Note AN 5288 for additional handling information and proper procedures.

Moisture Sensitivity

This product has a Moisture Sensitive Level 3 rating per JEDEC J-STD-020. Refer to Avago Application Note AN5305, Handling of Moisture Sensitive Surface Mount Devices, for additional details and a review of proper handling procedures.

A. Storage before use

- An Unopened moisture barrier bag (MBB) can be stored at 40°C/90%RH for 12 months. If the actual shelf life has exceeded 12 months and the humidity Indicator Card (HIC) indicates that baking is not required, then it is safe to reflow the LEDs per the original MSL rating.
- It is recommended that the MBB not be opened prior to assembly (e.g. for IQC).

B. Control after opening the MBB

- The humidity indicator card (HIC) shall be read immediately upon opening of MBB.
- The LEDs must be kept at 30°C / 60%RH at all times and all high temperature related processes including soldering, curing or rework need to be completed within 168 hours.

C. Control for unfinished reel

- Unused LEDs must be stored in a sealed MBB with desiccant or desiccator at 5%RH.

D. Control of assembled boards

- If the PCB soldered with the LEDs is to be subjected to other high temperature processes, the PCB need to be stored in sealed MBB with desiccant or desiccator at 5%RH to ensure that all LEDs have not exceeded their floor life of 168 hours.

E. Baking is required if:

- The HIC indicator is not BROWN at 10% and is AZURE at 5%.
- The LEDs are exposed to condition of 30°C / 60% RH at any time.
- The Led floor life exceeded 168hrs.

The recommended baking condition is: $60\pm 5^{\circ}\text{C}$ for 20hrs

DISCLAIMER: Avago's products and software are not specifically designed, manufactured or authorized for sale as parts, components or assemblies for the planning, construction, maintenance or direct operation of a nuclear facility or for use in medical devices or applications. Customer is solely responsible, and waives all rights to make claims against avago or its suppliers, for all loss, damage, expense or liability in connection with such use.

For product information and a complete list of distributors, please go to our web site: www.avagotech.com

Avago, Avago Technologies, and the A logo are trademarks of Avago Technologies in the United States and other countries. Data subject to change. Copyright © 2005-2012 Avago Technologies. All rights reserved. AV02-3793EN - September 13, 2012

AVAGO
TECHNOLOGIES