



**180-091 (H7) Square Flange Wall Mount Receptacle
Advanced Fiber Optic Connector
MIL-DTL-38999 Series III Type with Standard (Round) Holes**

**D38999
Series III**

B

MIL-DTL-38999 type advanced fiber optic receptacle connector



How To Order

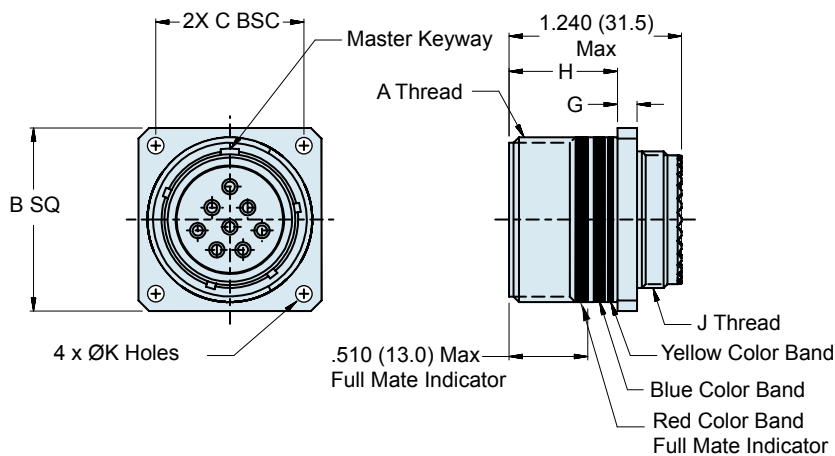
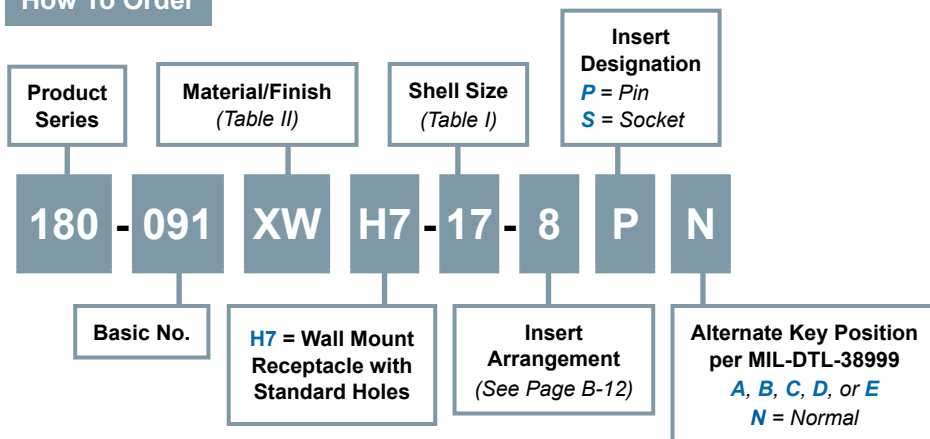

H7 - SQUARE FLANGE WALL MOUNT RECEPTACLE WITH STANDARD (ROUND) HOLES

Material and Finish

Shell: See Table II
Insulator: High Grade Rigid Dielectric
Seals: Fluorosilicone

Notes

Insert arrangement in accordance with MIL-STD-1560, See Page B-12.
Blue Color Band indicates rear release retention system.
For appropriate Glenair Terminus part numbers, see Glenair Drawing 181-001 and 181-002.
For recommended panel cutout, See Page B-13

**180-091 (H7) Square Flange Wall Mount Receptacle
Advanced Fiber Optic Connector
MIL-DTL-38999 Series III Type with Standard (Round) Holes**



MIL-DTL-38999
Series III Type

B

Table I

Shell Size Code	Shell Size	A Thread	B SQ	C BSC	G	H	J Thread	Ø K Holes
B	11	.7500-.1P-.3L-TS-2A	1.043 (26.5) 1.019 (25.9)	.812 (20.6)	.144 (3.7) .083 (2.1)	.823 (20.9) .768 (19.5)	M15 x 1.0-6g 0.100R	.136 (3.5) .120 (3.0)
C	13	.8750-.1P-.3L-TS-2A	1.138 (28.9) 1.114 (28.3)	.906 (23.0)	.144 (3.7) .083 (2.1)	.823 (20.9) .768 (19.5)	M18 x 1.0-6g 0.100R	.136 (3.5) .120 (3.0)
D	15	1.0000-.1P-.3L-TS-2A	1.232 (31.3) 1.208 (30.7)	.969 (24.6)	.144 (3.7) .083 (2.1)	.823 (20.9) .768 (19.5)	M22 x 1.0-6g 0.100R	.136 (3.5) .120 (3.0)
E	17	1.1875-.1P-.3L-TS-2A	1.323 (33.6) 1.299 (33.0)	1.062 (27.0)	.144 (3.7) .083 (2.1)	.823 (20.9) .768 (19.5)	M25 x 1.0-6g 0.100R	.136 (3.5) .120 (3.0)
F	19	1.2500-.1P-.3L-TS-2A	1.449 (36.8) 1.425 (36.2)	1.156 (29.4)	.144 (3.7) .083 (2.1)	.823 (20.9) .768 (19.5)	M28 x 1.0-6g 0.100R	.136 (3.5) .120 (3.0)
G	21	1.3750-.1P-.3L-TS-2A	1.575 (40.0) 1.551 (39.4)	1.250 (31.8)	.171 (65.2) .083 (39.8)	.791 (20.0) .736 (18.7)	M31 x 1.0-6g 0.100R	.136 (3.5) .120 (3.0)
H	23	1.5000-.1P-.3L-TS-2A	1.701 (43.2) 1.677 (42.6)	1.375 (34.9)	.171 (65.2) .083 (39.8)	.791 (20.0) .736 (18.7)	M34 x 1.0-6g 0.100R	.162 (4.1) .146 (3.7)
J	25	1.6250-.1P-.3L-TS-2A	1.823 (46.3) 1.799 (45.7)	1.500 (38.1)	.171 (65.2) .083 (39.8)	.791 (20.0) .736 (18.7)	M37 x 1.0-6g 0.100R	.162 (4.1) .146 (3.7)

Table II: Material and Finish

Code	Material	Finish Description
M	Aluminum Alloy	Electroless Nickel
MT		Nickel - PTFE, Grey
NF		Cadmium, Olive Drab
ZN		Zinc-Nickel, Olive Drab
ZNU		Zinc-Nickel, Black
XM	Composite	Electroless Nickel
XMT		Nickel - PTFE, Grey
XW		Cadmium, Olive Drab
XZN		Zinc-Nickel, Black
MS	Stainless Steel	Electroless Nickel
ZL		Electro-Deposited Nickel
ZI		Passivate

Refer to Appendix for material/finish details