

# Rubber Seated Butterfly Valve Series 100/200

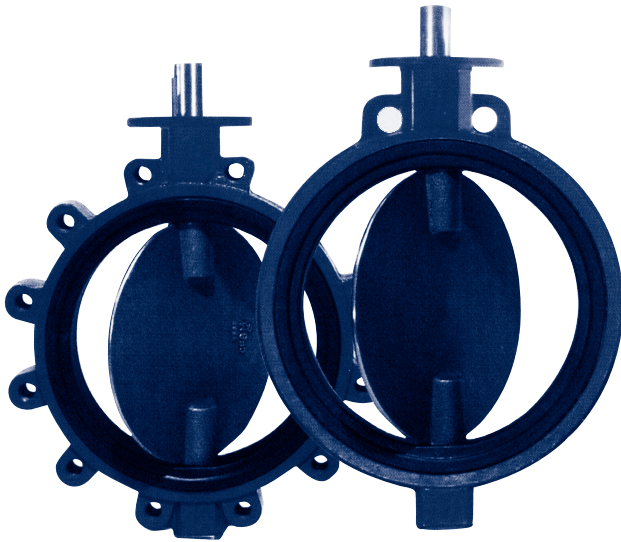

## Construction Specifications:

**Sizes:** 2" through 48"

**Body:** Cast Iron — Wafer or Lug\*

**Disc:** Ductile Iron  
Epoxy Coated Stainless Steel  
Aluminum Bronze

**Stem:** Stainless Steel

**Resilient Seat:** EPDM BUNA-N Viton

**Actuation Options:** Worm Gear Lever  
Pneumatic Electric

**Pressure Ratings:** 2"-12" — 175 psi  
14" and larger — 150 psi

\*for installation between ANSI Class 125 flanges

## Features:

- All cast body machined to high tolerances. Guaranteed standard dimensions for interchangeability of parts and actuators.
- Shaft bushings are impact and corrosion resistant materials. Protects the shaft from side thrust of actuators.
- Special double-V-shape of stem seal self-adjusts to protect the stem area for either vacuum or pressure use.
- Stem and body are isolated from line media by seal created between disc flats and flat surface of seat.
- The special snap-in Resil-O-Seat design fixes seat in place without bonding. The Resil-O-Seat is 100% field replaceable — no tools required.
- Molded O-ring in the Resil-O-Seat forms a seal against all standard flanges. Gasketing requirements are eliminated.
- Disc edge is machined and buffed, providing a bubble tight shutoff and maximum seat life.
- All valves are factory tested at their rated pressure.



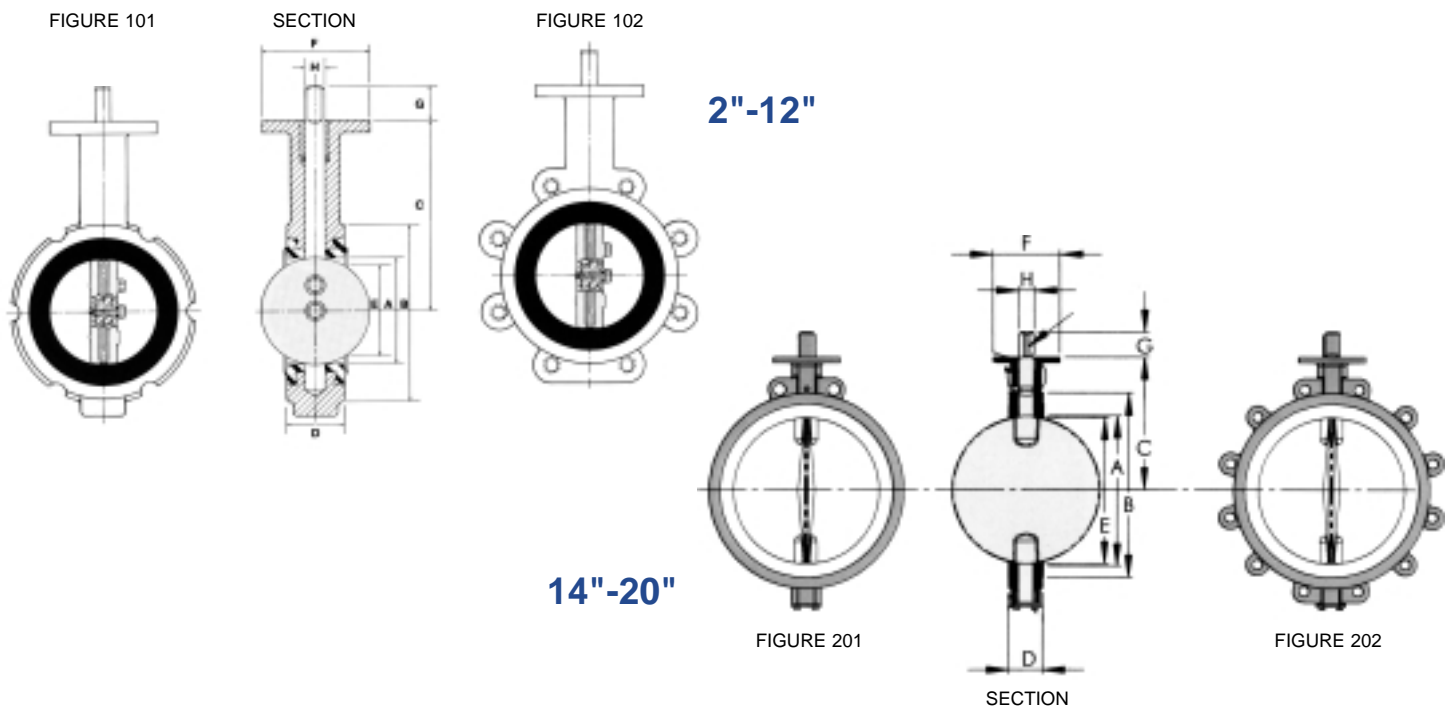

### Valve Dimensions

Size	A	B	C	D	E	F	G	H
2"	2-1/8	4-1/8	5-1/2	1-5/8	1-11/16	4	1-1/4	9/16
2.5"	2-9/16	4-7/8	6	1-3/4	2-3/16	4	1-1/4	9/16
3"	3-1/8	5-3/8	6-1/4	1-3/4	2-7/8	4	1-1/4	9/16
4"	4-1/8	6-7/8	7	2	3-7/8	4	1-1/4	5/8
5"	5-3/16	7-5/8	7-1/2	2-1/8	5	4	1-1/4	5/8
6"	6-1/8	8-3/4	8	2-1/8	6	4	1-1/4	5/8
8"	8-1/8	11	9-1/2	2-1/2	8	6	1-1/4	3/4
10"	10-1/8	13-3/8	10-3/4	2-1/2	10-1/16	6	1-1/4	7/8
12"	12-3/32	16-1/8	12-1/4	3	11-15/16	6	2	1-1/8
14"	13-1/4	17-9/16	12	3	13-1/8	6	2-1/4	1-3/8
16"	15-1/4	20-1/8	12-61/64	4	15	6	2-1/4	1-5/8
18"	17-1/4	21-1/2	14-1/2	4-1/4	16-7/8	8	3	1-7/8
20"	19-1/4	23-3/4	15-7/8	5	18-3/4	8	3	2-1/8
24" and larger — consult factory								

Note: Valves cannot be used on a pipe or flange with an inside diameter less than the "E" dimension.

## General Service Rubber Seated Butterfly Valve Specifications

### General

Valves shall be of the wafer (or lug wafer) design for installation between ANSI B16.1 125# flanges. All valves shall be capable of bi-directional, bubble tight service to the rated pressure. Valves shall be Pratt Series 100/200 or approved equal.

### Pressure rating

2" through 12" – 200 psi  
14" and larger – 150 psi

### Body

The valve body shall be cast iron ASTM A-126 Class B. Laying length shall conform to MSS-SP67, latest revision.

### Disc

Valve disc shall be epoxy coated ductile iron ASTM A-536 Grade 65-45-12 (or 316 stainless steel).

### Shaft

Valve shaft shall be stainless steel type 416 or 17-4.

### Seat

Seat shall be EPDM (or Buna-n or Viton). Seats shall be located in the valve body and shall be field replaceable.

### Shaft Seal

Shaft seal shall be self adjusting V-type and shall be suitable for pressure or vacuum service.

### Testing

All valve shall be leak tested in the factory at their rated pressure.