

# DATA SHEET

## BZM55-C2V4 SERIES

### SURFACE MOUNT ZENER DIODES

**VOLTAGE** 2.4 to 47 Volts

**POWER** 500 mWatts

**MICRO-MELF**

Unit : inch (mm)

#### FEATURES

- Planar Die construction
- 500mW Power Dissipation
- Ideally Suited for Automated Assembly Processes

#### MECHANICAL DATA

- Case: Molded Glass MICRO-MELF
- Terminals: Solderable per MIL-STD-202E, Method 208
- Polarity: See Diagram Below
- Approx. Weight: 0.01 grams
- Mounting Position: Any
- Packing information

T/R - 2.5K per 7" plastic Reel

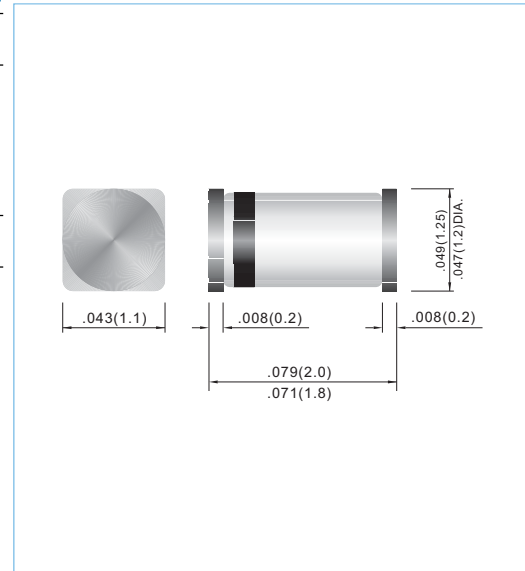

### MAXIMUM RATINGS AND ELECTRICAL CHARACTERISTICS

Parameter	Symbol	Value	Units
Power Dissipation at Tamb = 25 °C	P <sub>TOT</sub>	500	mW
Junction Temperature	T <sub>J</sub>	175	°C
Storage Temperature Range	T <sub>S</sub>	-65 to +175	°C

Valid provided that leads at a distance of 8mm from case are kept at ambient temperature.

Parameter	Symbol	Min.	Typ.	Max.	Units
Thermal Resistance Junction to Ambient Air	R <sub>thA</sub>	--	--	0.3	K/mW
Forward Voltage at I <sub>F</sub> = 100mA	V <sub>F</sub>	--	--	1	V

Valid provided that leads at a distance of 8mm from case are kept at ambient temperature.

Part Number	Nominal Zener Voltage			Max. Zener Impedance				Max Reverse Leakage Current	
	V <sub>Z</sub> @ I <sub>ZT</sub>			Z <sub>zT</sub> @ I <sub>ZT</sub>		Z <sub>zK</sub> @ I <sub>zK</sub>		I <sub>R</sub> @ V <sub>R</sub>	
	Nom. V	Min. V	Max. V	Ω	mA	Ω	mA	uA	V
BZM55-C2V4	2.40	2.28	2.56	85	5.0	600	1.00	50	1.0
BZM55-C2V7	2.70	2.50	2.90	85	5.0	600	1.00	10	1.0
BZM55-C3V0	3.00	2.80	3.20	85	5.0	600	1.00	4.0	1.0
BZM55-C3V3	3.30	3.10	3.50	85	5.0	600	1.00	2.0	1.0
BZM55-C3V6	3.60	3.40	3.80	85	5.0	600	1.00	2.0	1.0
BZM55-C3V9	3.90	3.70	4.10	85	5.0	600	1.00	2.0	1.0
BZM55-C4V3	4.30	4.00	4.60	75	5.0	600	1.00	1.0	1.0
BZM55-C4V7	4.70	4.40	5.00	60	5.0	600	1.00	0.5	1.0
BZM55-C5V1	5.10	4.80	5.40	35	5.0	550	1.00	0.1	1.0
BZM55-C5V6	5.60	5.20	6.00	25	5.0	450	1.00	0.1	1.0
BZM55-C6V2	6.20	5.80	6.60	10	5.0	200	1.00	0.1	2.0
BZM55-C6V8	6.80	6.40	7.20	8	5.0	150	1.00	0.1	3.0
BZM55-C7V5	7.50	7.00	7.90	7	5.0	50	1.00	0.1	5.0
BZM55-C8V2	8.20	7.70	8.70	7	5.0	50	1.00	0.1	6.0
BZM55-C9V1	9.10	8.50	9.60	10	5.0	50	1.00	0.1	7.0
BZM55-C10	10.00	9.40	10.60	15	5.0	70	1.00	0.1	7.5
BZM55-C11	11.00	10.40	11.60	20	5.0	70	1.00	0.1	8.5
BZM55-C12	12.00	11.40	12.70	20	5.0	90	1.00	0.1	9.0
BZM55-C13	13.00	12.40	14.10	26	5.0	110	1.00	0.1	10.0
BZM55-C15	15.00	13.80	15.60	30	5.0	110	1.00	0.1	11.0
BZM55-C16	16.00	15.30	17.10	40	5.0	170	1.00	0.1	12.0
BZM55-C18	18.00	16.80	19.10	50	5.0	170	1.00	0.1	14.0
BZM55-C20	20.00	18.80	21.20	55	5.0	220	1.00	0.1	15.0
BZM55-C22	22.00	20.80	23.30	55	5.0	220	1.00	0.1	17.0
BZM55-C24	24.00	22.80	25.60	80	5.0	220	1.00	0.1	18.0
BZM55-C27	27.00	25.10	28.90	80	5.0	220	1.00	0.1	20.0
BZM55-C30	30.00	28.00	32.00	80	5.0	220	1.00	0.1	22.0
BZM55-C33	33.00	31.00	35.00	80	5.0	220	1.00	0.1	24.0
BZM55-C36	36.00	34.00	38.00	80	5.0	220	1.00	0.1	27.0
BZM55-C39	39.00	37.00	41.00	90	2.5	500	1.00	0.1	30.0
BZM55-C43	43.00	40.00	46.00	90	2.5	600	1.00	0.1	33.0
BZM55-C47	47.00	44.00	50.00	110	2.5	700	1.00	0.1	36.0

Notes.

STANDARD VOLTAGE TOLERANCE IS + 5% AND :

- SUFFIX " A " FOR + 1%
- SUFFIX " B " FOR + 2%
- SUFFIX " C " FOR + 5%
- SUFFIX " D " FOR + 20%

## RATING AND CHARACTERISTIC CURVES

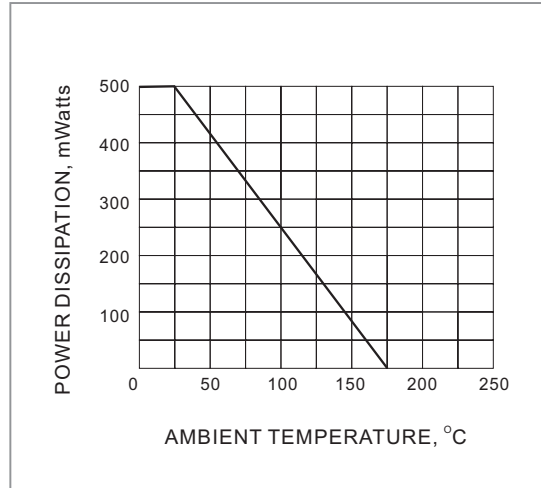

**FIG. 1 POWER DERATING CURVE**

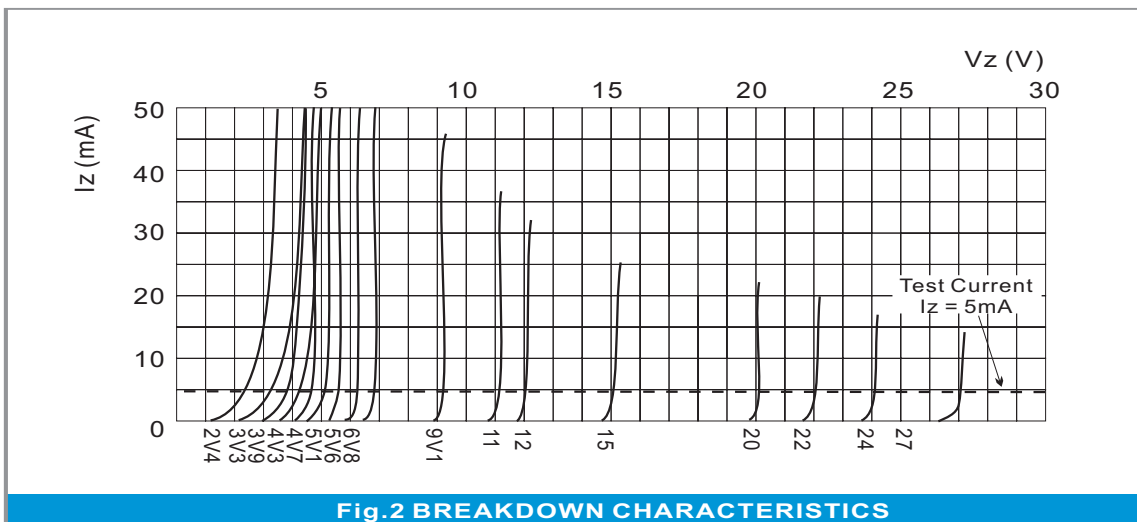

**Fig.2 BREAKDOWN CHARACTERISTICS**