

FEATURES

- **Audio Input/Output**
 - Up to Three Synchronous Serial Audio Inputs (6 Channels)
 - Up to Two Synchronous Serial Audio Outputs (4 Channels)
 - Left, Right and I²S Input Data Formats: 16-, 20-, or 24-Bit Data
 - Left, Right and I²S Output Data Formats: 16-, 20-, or 24-Bit Data
 - 64 × Fs Bit Clock Rate
 - 24.576-MHz XTAL Input for Master Clock Modes and Clock Auto Detection
 - Slave Mode 256, 384, or 512 × Fs MCLKIN With Automatic Clock Rate Detection
 - Slave Mode 32-, 44.1-, and 48-kHz Fs With Auto Sample Rate Detection
 - Master Mode – 48-kHz Fs 10 Multiplexed Stereo Analog Inputs Selectable Into One Stereo ADC. ADC Maximum Input Level: 1 Vrms SE
 - Three Stereo Differential PWM Outputs
 - High-Quality DNR 100-dBA (Typical) ADC Channel Performance (2 Channels) With Master Mode Clock
 - High-Quality DNR 105-dBA (Typical) PWM Channel Performance (6 Channels)
 - One Single-Ended Analog Stereo Line Driver Output With 1 of 10 Selectable Inputs, 10-kΩ, 100-pF Drive Capability (Maximum Output Level: 1 Vrms)
 - Line-Out Supports Left/Right, Left/Left, and Right/Right Combinations
- **Audio Digital Signal Processor**
 - Programmable Functionality
 - 135-MHz Operation
 - 48-Bit Datapath With 76-Bit Accumulator
 - Hardware Single Cycle Multiplier (28 × 48)
 - Two Memory Loads and One Memory Store Per Cycle
 - Usable 1K Words Data RAM (48 Bit) and Usable 1K Coefficient RAM (28 Bit)
 - 3.25K Words Instruction Program RAM (2.8K Words Available)
 - 360 mS at 48 KHz, 17,408 Words 24-Bit Delay Memory
- **PWM Features**
 - Proven PurePath Digital™ Technology
 - Fourth-Order Chaotic Noise Shaper With Non-Linear Correction
 - High-Quality DNR 105 dBA (Typical) PWM Performance
 - Click and Pop Minimizing at Power Up/Down Using TI Patented Technology
- **General Features**
 - Easy-to-Use Control Interface
 - I²C Serial Control Master and Slave Interface
 - Control Interface Operational Without External MCLK Input
 - Single 3.3-V Power Supply
 - Integrated Regulators
 - 100-Pin TQFP Package
 - M8051 Device Controller
 - Auto Clock and Serial Data Rate Detection and Automatic Device Configuration Without Audible Artifacts



Please be aware that an important notice concerning availability, standard warranty, and use in critical applications of Texas Instruments semiconductor products and disclaimers thereto appears at the end of this data sheet.

PurePath Digital is a trademark of Texas Instruments.

TAS3308 DIGITAL AUDIO PROCESSOR WITH ANALOG INTERFACE

SLES215A—FEBRUARY 2008—REVISED MARCH 2008

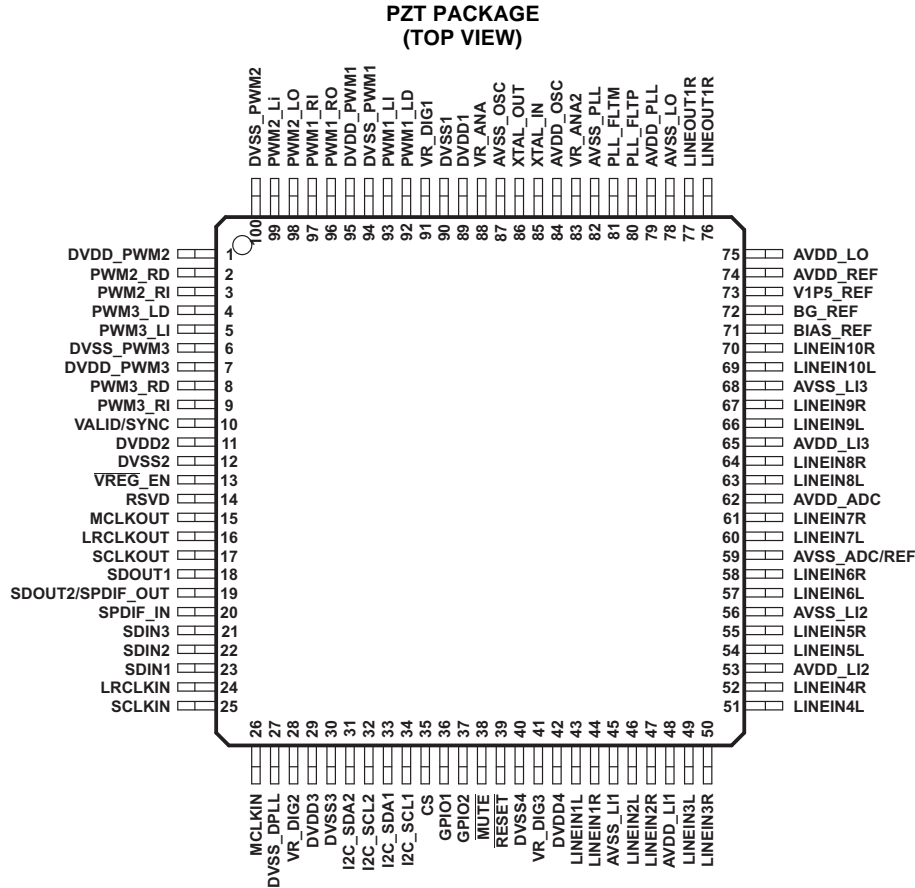

DESCRIPTION/ORDERING INFORMATION

TAS3308 is an audio system-on-a-chip (SOC) designed for digital TV audio systems and mini/micro component applications. It includes analog and digital audio interface. For analog input and output the TAS3308 has ten multiplexed stereo inputs with one stereo ADC and three stereo PWM outputs. For digital input and output the TAS3308 has three I²S inputs and two I²S outputs. One I²S output can also be configured to be S/SPDIF encoded PCM data.

TAS3308 has a programmable audio DSP that preserves high-quality audio by using a 48-bit data path, 28-bit filter coefficients, and a single cycle 28 × 48-bit multiplier. The programmability feature allows users to customize features in the DSP RAM.

ORDERING INFORMATION

T _A	PACKAGE ⁽¹⁾	ORDERABLE PART NUMBER	TOP-SIDE MARKING
0°C to 70°C	TQFP – PZT	Tray	TAS3308PZT
		Tape and reel	TAS3308PZTR

(1) For the most current package and ordering information, see the Package Option Addendum at the end of this document, or see the TI website at www.ti.com.

The TAS3308 comprises nine functional blocks.

- Analog input/MUX/stereo ADC
- Three stereo PWM output for speaker/headphone/stereo
- Line driver outputs
- Clock, digital PLL, analog PLL, serial data interface, and auto-detect system
- Serial control interface/device control
- Audio DSP – digital audio processing
- 8051 device controller
- Power supply
- Internal references

BLOCK DIAGRAM

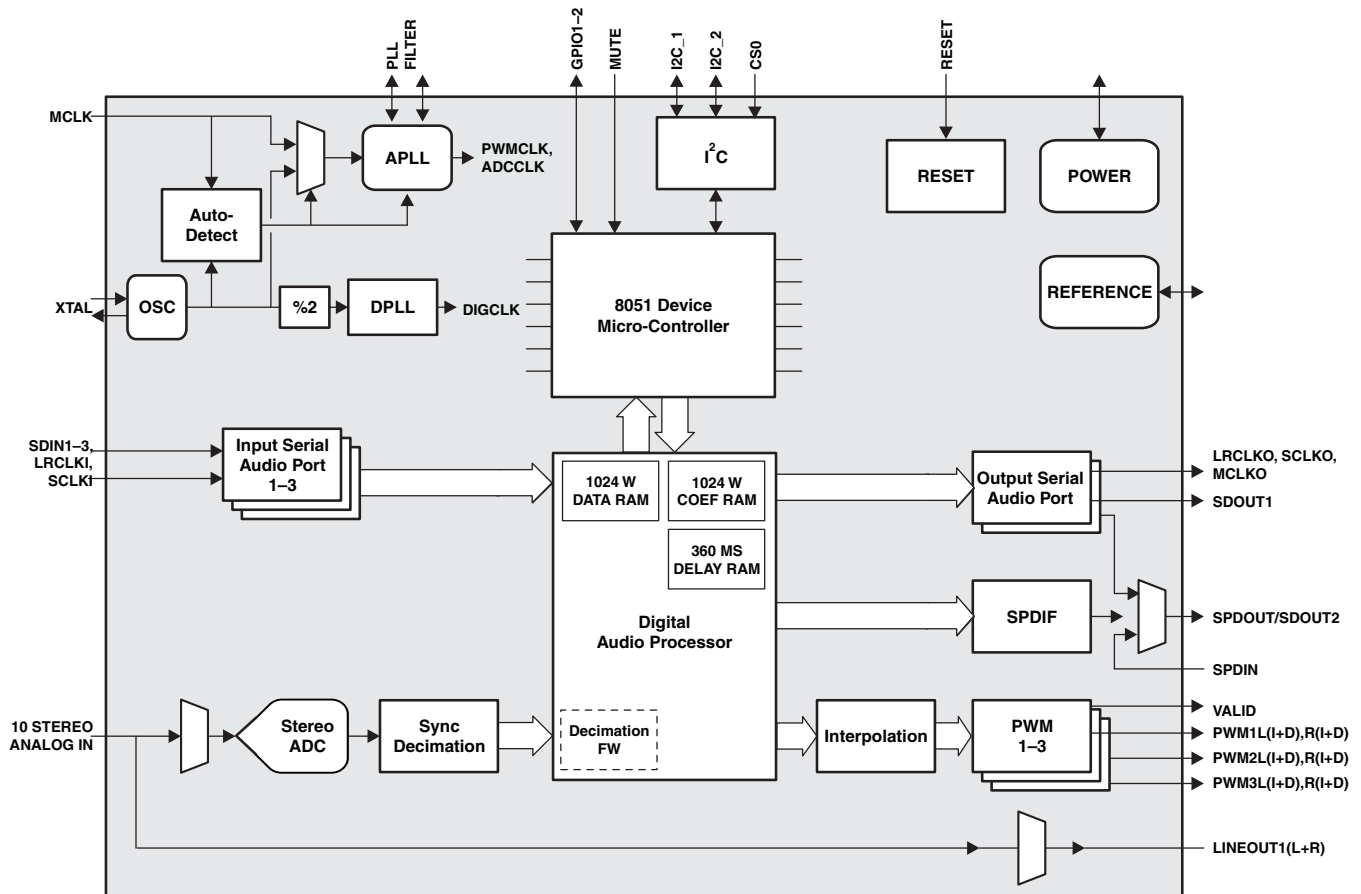

APPLICATION INFORMATION

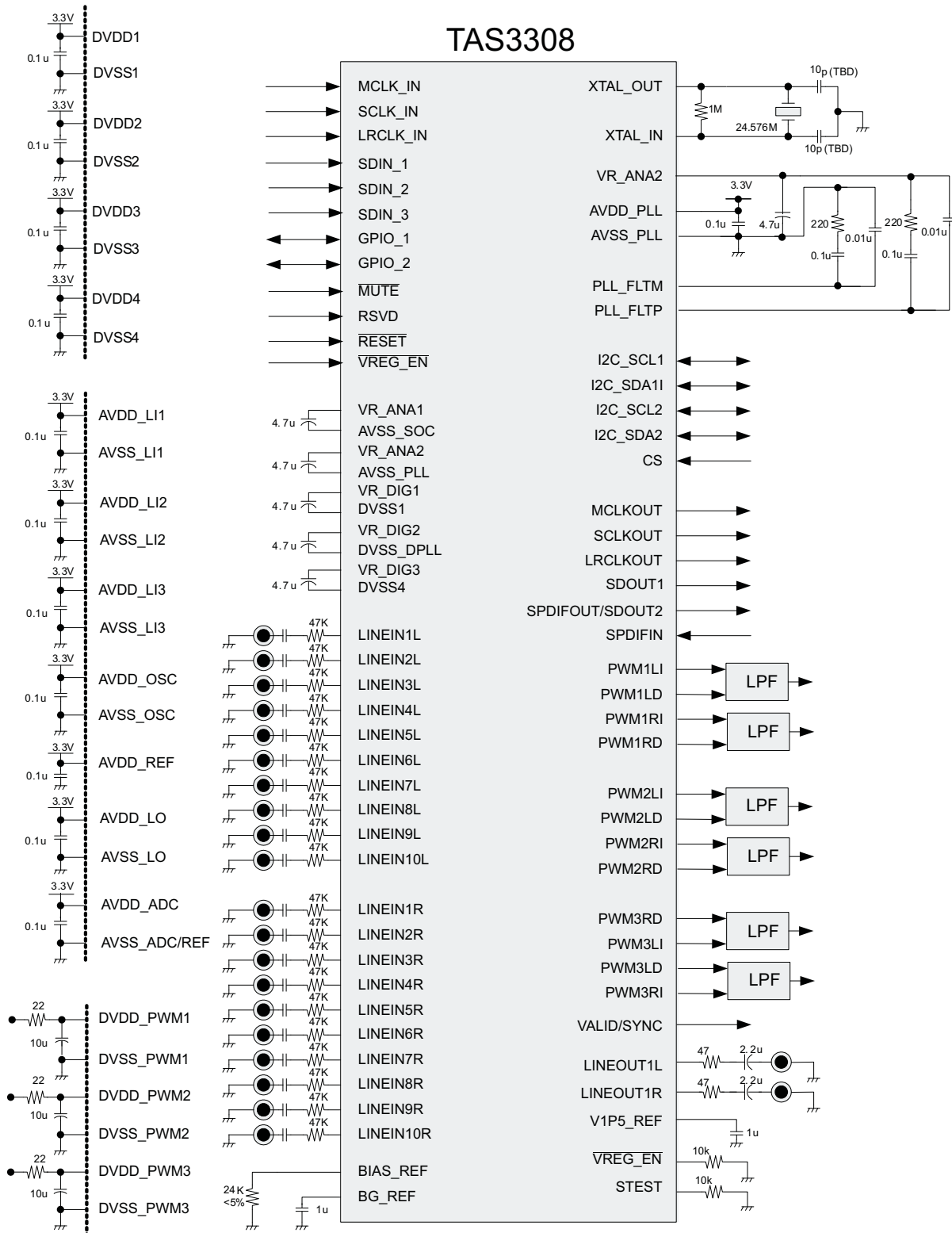

Figure 1. Peripheral Connections

ABSOLUTE MAXIMUM RATINGS⁽¹⁾

over operating free-air temperature range (unless otherwise noted)

			MIN	MAX	UNIT
DVDD	Supply voltage range		-0.5	3.8	V
AVDD			-0.5	3.8	
DVDD_PWM			-0.5	3.8	
V _I	Input voltage range	3.3 V TTL	-0.5	V _{DD} S + 0.5	V
		3.3 V LVCMOS	-0.5	V _{DD} S + 0.5	
		3.3 V analog	-0.5	AV _{DD} S + 0.5	
		1.8 V LVCMOS	-0.5	AV _{DD} ⁽²⁾ + 0.5	
V _O	Output voltage range	3.3 V TTL	-0.5	V _{DD} S + 0.5	V
		3.3 V LVCMOS	-0.5	V _{DD} S + 0.5	
		3.3 V analog	-0.5	AV _{DD} S + 0.5	
		1.8 V LVCMOS	-0.5	DV _{DD} ⁽³⁾ + 0.5	
			-0.5	AV _{DD} ⁽⁴⁾ + 0.5	
I _{IK}	Input clamp current	V _I < 0 or V _I > DVDD		±20	mA
I _{OK}	Output clamp current	V _O < 0 or V _O > DVDD		±20	mA
T _{stg}	Storage temperature range		-65	150	°C
	Lead temperature 1.6 mm (1/16) inch from case for 10 seconds			260	°C

- (1) Stresses beyond those listed under “absolute ratings” may cause permanent damage to the device. These are stress ratings only, and functional operation of the device at these or any other conditions beyond those indicated under “recommended operation conditions” is not implied. Exposure to absolute-maximum conditions for extended periods may affect device reliability.
- (2) AVDD is an internal 1.8-V supply derived from a regulator in the TAS3308 chip. Pin XTALI is the only TAS3308 input that is referenced to this 1.8-V logic supply. The absolute maximum rating listed is for reference; only a crystal should be connected to XTALI.
- (3) DVDD is an internal 1.8-V supply derived from regulators in the TAS3308 chip. DVDD is routed to DVDD_BYPASS_CAP to provide access to external filter capacitors, but should not be used to source power to external devices.
- (4) Pin XTALO is the only TAS3308 output that is derived from the internal 1.8-V logic supply AVDD. The absolute maximum rating listed is for reference; only a crystal should be connected to XTALO. AVDD is also routed to AVDD_BYPASS_CAP to provide access to external filter capacitors, but should not be used to source power to external devices.

RECOMMENDED OPERATING CONDITIONS

over operating free-air temperature range (unless otherwise noted)

PARAMETER		MEASUREMENTS	MIN	NOM	MAX	UNIT
DVDD	Digital supply voltage		3	3.3	3.6	V
AVDD	Analog supply voltage	3.3 V analog	3	3.3	3.6	V
DVDD_PWM	PWM supply voltage	3.3 V PWM	3	3.3	3.6	V
V _{IH}	High-level input voltage	3.3 V TTL	2		V	
		3.3 V LVCMOS (I ² C)	0.7 × V _{DD} S			
		1.8 V LVCMOS (XTL_IN)	1.26			
V _{IL}	Low-level input voltage	3.3 V TTL	0.8		V	
		3.3 V LVCMOS (I ² C)	0	0.3 × V _{DD} S		
		1.8 V LVCMOS (XTL_IN)	0.54			
T _A	Operating ambient air temperature range	(specifying parametrics)	0	25	70	°C
		(specifying functions)	-20	25	70	

TAS3308

DIGITAL AUDIO PROCESSOR WITH ANALOG INTERFACE

SLES215A–FEBRUARY 2008–REVISED MARCH 2008

ELECTRICAL CHARACTERISTICS

over operating free-air temperature range (unless otherwise noted)

PARAMETER		MEASUREMENT	TEST CONDITIONS	MIN	MAX	UNITS
V _{OH}	High-level output voltage	3.3 V TTL	I _{OH} = -4 mA	2.4		V
		3.3 V LVCMOS (I ² C)	I _{OH} = -0.10 mA	V _{DD5} - 0.2		V
		1.8 V LVCMOS (XTL_OUT)	I _{OH} = -0.6 mA	1.197		V
V _{OL}	Low-level output voltage	3.3 V TTL	I _{OL} = 4 mA		0.5	V
		3.3 V LVCMOS (I ² C)	I _{OL} = 0.10 mA		0.2	V
		1.8 V LVCMOS (XTL_OUT)	I _{OL} = 1.8 mA		0.585	V
I _{OZ}	High-impedance output current	3.3 V TTL			±20	μA
		3.3 V LVCMOS (I ² C)	Driver only, driver disable		±20	μA
I _{IL} ⁽¹⁾	Low-level input current	3.3 V TTL	V _I = V _{IL}		±1	μA
		3.3 V LVCMOS (I ² C)	V _I = V _{IL} , Receiver only		±1	μA
		1.8 V LVCMOS (XTL_IN)	V _I = V _{IL}		±1	μA
I _{IH} ⁽²⁾	High-level input current	1.8 V LVCMOS (XTL_IN)	V _I = V _{IH}		±1	μA
		3.3 V LVCMOS (I ² C)	V _I = V _{IH} , Receiver only		±1	μA
		3.3 V TTL	V _I = V _{IH}		±1	μA
I _{DVDD}	Digital supply current		DSP clock = 135 MHz LRCLKIN/LRCLKOUT = 48 KHz, XTALI = 24.576 MHz		160	mA
I _{AVDD}	Analog supply current		DSP clock = 135 MHz LRCLKIN/LRCLKOUT = 48 KHz, XTALI = 24.576 MHz		40	mA
I _{DVDD}	Digital supply current		RESET = LOW		100	mA
I _{AVDD}	Analog supply current		RESET = LOW		10	mA

- (1) Value given is for those input pins that connect to an internal pullup resistor as well as an input buffer. For inputs that have a pulldown resistor or no resistor, I_{IL} is ±1 μA.
- (2) Value given is for those input pins that connect to an internal pulldown resistor as well as an input buffer. For inputs that have a pullup resistor or no resistor, I_{IH} is ±1 μA.

PACKAGING INFORMATION

Orderable Device	Status ⁽¹⁾	Package Type	Package Drawing	Pins	Package Qty	Eco Plan ⁽²⁾	Lead/Ball Finish	MSL Peak Temp ⁽³⁾
TAS3308PZT	ACTIVE	TQFP	PZT	100	90	Green (RoHS & no Sb/Br)	CU NIPDAU	Level-3-260C-168 HR
TAS3308PZTR	ACTIVE	TQFP	PZT	100	1000	Green (RoHS & no Sb/Br)	CU NIPDAU	Level-3-260C-168 HR

⁽¹⁾ The marketing status values are defined as follows:

ACTIVE: Product device recommended for new designs.

LIFEBUY: TI has announced that the device will be discontinued, and a lifetime-buy period is in effect.

NRND: Not recommended for new designs. Device is in production to support existing customers, but TI does not recommend using this part in a new design.

PREVIEW: Device has been announced but is not in production. Samples may or may not be available.

OBsolete: TI has discontinued the production of the device.

⁽²⁾ Eco Plan - The planned eco-friendly classification: Pb-Free (RoHS), Pb-Free (RoHS Exempt), or Green (RoHS & no Sb/Br) - please check <http://www.ti.com/productcontent> for the latest availability information and additional product content details.

TBD: The Pb-Free/Green conversion plan has not been defined.

Pb-Free (RoHS): TI's terms "Lead-Free" or "Pb-Free" mean semiconductor products that are compatible with the current RoHS requirements for all 6 substances, including the requirement that lead not exceed 0.1% by weight in homogeneous materials. Where designed to be soldered at high temperatures, TI Pb-Free products are suitable for use in specified lead-free processes.

Pb-Free (RoHS Exempt): This component has a RoHS exemption for either 1) lead-based flip-chip solder bumps used between the die and package, or 2) lead-based die adhesive used between the die and leadframe. The component is otherwise considered Pb-Free (RoHS compatible) as defined above.

Green (RoHS & no Sb/Br): TI defines "Green" to mean Pb-Free (RoHS compatible), and free of Bromine (Br) and Antimony (Sb) based flame retardants (Br or Sb do not exceed 0.1% by weight in homogeneous material)

⁽³⁾ MSL, Peak Temp. -- The Moisture Sensitivity Level rating according to the JEDEC industry standard classifications, and peak solder temperature.

Important Information and Disclaimer:The information provided on this page represents TI's knowledge and belief as of the date that it is provided. TI bases its knowledge and belief on information provided by third parties, and makes no representation or warranty as to the accuracy of such information. Efforts are underway to better integrate information from third parties. TI has taken and continues to take reasonable steps to provide representative and accurate information but may not have conducted destructive testing or chemical analysis on incoming materials and chemicals. TI and TI suppliers consider certain information to be proprietary, and thus CAS numbers and other limited information may not be available for release.

In no event shall TI's liability arising out of such information exceed the total purchase price of the TI part(s) at issue in this document sold by TI to Customer on an annual basis.

TAPE AND REEL INFORMATION



QUADRANT ASSIGNMENTS FOR PIN 1 ORIENTATION IN TAPE



*All dimensions are nominal

Device	Package Type	Package Drawing	Pins	SPQ	Reel Diameter (mm)	Reel Width W1 (mm)	A0 (mm)	B0 (mm)	K0 (mm)	P1 (mm)	W (mm)	Pin1 Quadrant
TAS3308PZTR	TQFP	PZT	100	1000	330.0	24.4	17.0	17.0	1.5	20.0	24.0	Q2

TAPE AND REEL BOX DIMENSIONS



*All dimensions are nominal

Device	Package Type	Package Drawing	Pins	SPQ	Length (mm)	Width (mm)	Height (mm)
TAS3308PZTR	TQFP	PZT	100	1000	346.0	346.0	41.0

PZT (S-PQFP-G100)

PLASTIC QUAD FLATPACK

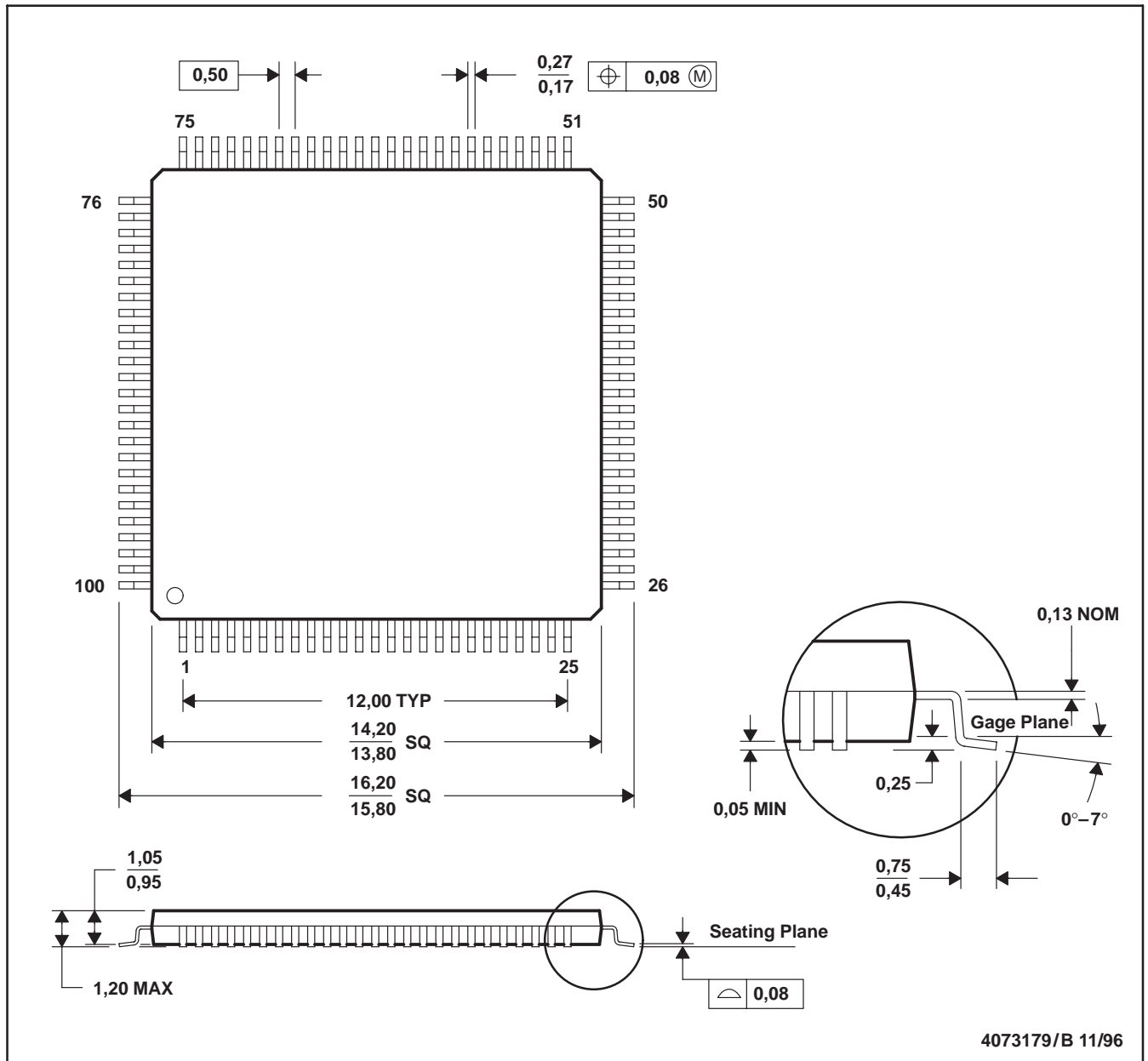

- NOTES: A. All linear dimensions are in millimeters.
 B. This drawing is subject to change without notice.
 C. Falls within JEDEC MS-026

IMPORTANT NOTICE

Texas Instruments Incorporated and its subsidiaries (TI) reserve the right to make corrections, modifications, enhancements, improvements, and other changes to its products and services at any time and to discontinue any product or service without notice. Customers should obtain the latest relevant information before placing orders and should verify that such information is current and complete. All products are sold subject to TI's terms and conditions of sale supplied at the time of order acknowledgment.

TI warrants performance of its hardware products to the specifications applicable at the time of sale in accordance with TI's standard warranty. Testing and other quality control techniques are used to the extent TI deems necessary to support this warranty. Except where mandated by government requirements, testing of all parameters of each product is not necessarily performed.

TI assumes no liability for applications assistance or customer product design. Customers are responsible for their products and applications using TI components. To minimize the risks associated with customer products and applications, customers should provide adequate design and operating safeguards.

TI does not warrant or represent that any license, either express or implied, is granted under any TI patent right, copyright, mask work right, or other TI intellectual property right relating to any combination, machine, or process in which TI products or services are used. Information published by TI regarding third-party products or services does not constitute a license from TI to use such products or services or a warranty or endorsement thereof. Use of such information may require a license from a third party under the patents or other intellectual property of the third party, or a license from TI under the patents or other intellectual property of TI.

Reproduction of TI information in TI data books or data sheets is permissible only if reproduction is without alteration and is accompanied by all associated warranties, conditions, limitations, and notices. Reproduction of this information with alteration is an unfair and deceptive business practice. TI is not responsible or liable for such altered documentation. Information of third parties may be subject to additional restrictions.

Resale of TI products or services with statements different from or beyond the parameters stated by TI for that product or service voids all express and any implied warranties for the associated TI product or service and is an unfair and deceptive business practice. TI is not responsible or liable for any such statements.

TI products are not authorized for use in safety-critical applications (such as life support) where a failure of the TI product would reasonably be expected to cause severe personal injury or death, unless officers of the parties have executed an agreement specifically governing such use. Buyers represent that they have all necessary expertise in the safety and regulatory ramifications of their applications, and acknowledge and agree that they are solely responsible for all legal, regulatory and safety-related requirements concerning their products and any use of TI products in such safety-critical applications, notwithstanding any applications-related information or support that may be provided by TI. Further, Buyers must fully indemnify TI and its representatives against any damages arising out of the use of TI products in such safety-critical applications.

TI products are neither designed nor intended for use in military/aerospace applications or environments unless the TI products are specifically designated by TI as military-grade or "enhanced plastic." Only products designated by TI as military-grade meet military specifications. Buyers acknowledge and agree that any such use of TI products which TI has not designated as military-grade is solely at the Buyer's risk, and that they are solely responsible for compliance with all legal and regulatory requirements in connection with such use.

TI products are neither designed nor intended for use in automotive applications or environments unless the specific TI products are designated by TI as compliant with ISO/TS 16949 requirements. Buyers acknowledge and agree that, if they use any non-designated products in automotive applications, TI will not be responsible for any failure to meet such requirements.

Following are URLs where you can obtain information on other Texas Instruments products and application solutions:

Products

Amplifiers	amplifier.ti.com
Data Converters	dataconverter.ti.com
DSP	dsp.ti.com
Clocks and Timers	www.ti.com/clocks
Interface	interface.ti.com
Logic	logic.ti.com
Power Mgmt	power.ti.com
Microcontrollers	microcontroller.ti.com
RFID	www.ti-rfid.com
RF/IF and ZigBee® Solutions	www.ti.com/lprf

Applications

Audio	www.ti.com/audio
Automotive	www.ti.com/automotive
Broadband	www.ti.com/broadband
Digital Control	www.ti.com/digitalcontrol
Medical	www.ti.com/medical
Military	www.ti.com/military
Optical Networking	www.ti.com/opticalnetwork
Security	www.ti.com/security
Telephony	www.ti.com/telephony
Video & Imaging	www.ti.com/video
Wireless	www.ti.com/wireless

Mailing Address: Texas Instruments, Post Office Box 655303, Dallas, Texas 75265
Copyright © 2008, Texas Instruments Incorporated