

Verpackt in Tray
Verpackungseinheit 32 Stck

tray packaging
packaging unit 32 pcs

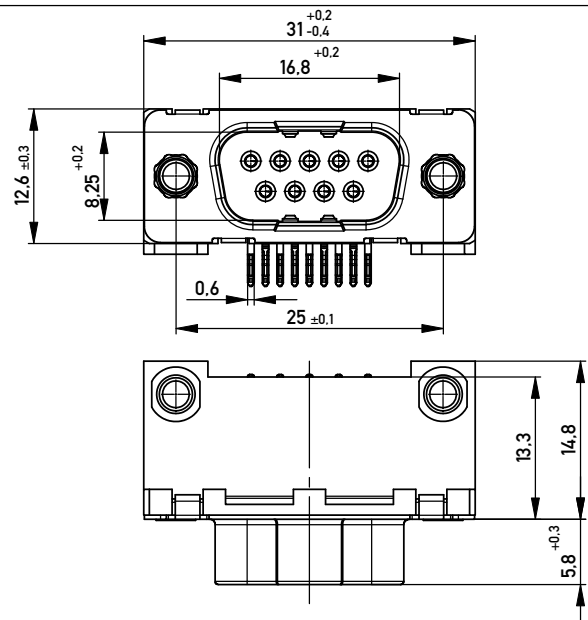

Mutter / nut

Bolzen / bolt

Anwendungsbeispiel / example of use

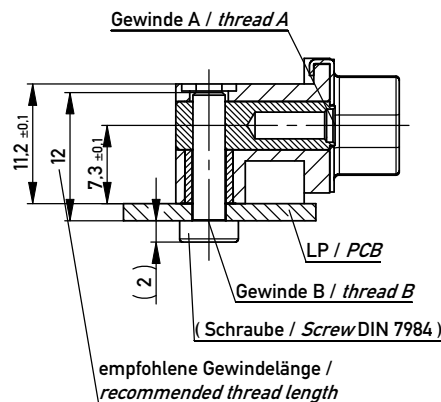
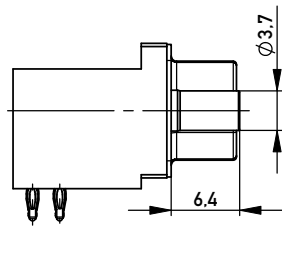
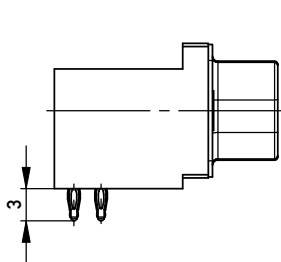

Beschriftung nach Bedruckungsvorschrift 174538
Part marking according to specification 174538

Anschlussbereich verzinkt
terminal area tin plating

Anforderungsstufe: 2
class: 2

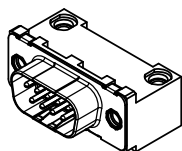

284502			#4-40	M3	
			M3	#4-40	
284501			#4-40	#4-40	
			M3	M3	
	#4-40	M3			
	M3	#4-40			
284500	#4-40	#4-40			
	M3	M3			
	Gewinde A thread A	Gewinde B thread B	Gewinde A thread A	Gewinde B thread B	
Ident-Nr. part-no. Tray / tray	Quermutter nut		Querbolzen bolt		Bemerkung remark

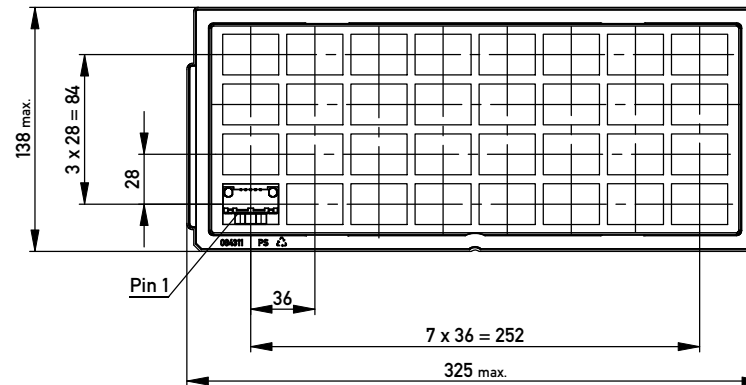

Sonstige Angaben siehe Zeichnung 204629 / Additional indications according to drawing 204629

Layoutvorschlag
recommended layout

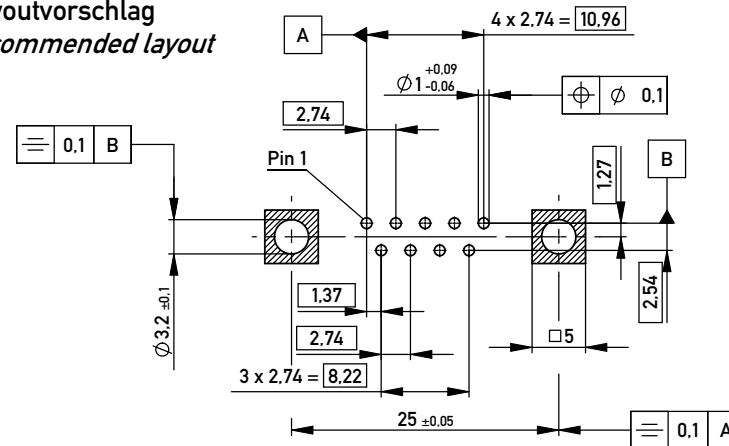

Sonstige Angaben siehe 164062 / additional indications according to 164062

Fehlende Masse und Angaben siehe DIN 41652 / Missing information and dimensions according to DIN 41652
Sonstige Angaben siehe Fertigungsunterlagen / Additional indications according to production documentation

Information:		Tolerances	Scale 2:1
All rights reserved. Only for Information. To ensure that this is the latest version of this drawing, please contact one of the ERNI companies before using.		 All Dimensions in mm	Designation TMC-P-09-EE-SV-Standard-BA8-ZV TMC-P-09-EE-SV-Standard-BA8-ZV
B		24.02.2010	224953
Index		Date	
Class			TMCP