



GPM8F377A Capacitive Touch M-KEY Sensor

Nov. 12, 2014

Preliminary Version 0.1

Important Notice

GENERALPLUS TECHNOLOGY INC. reserves the right to change this documentation without prior notice. Information provided by GENERALPLUS TECHNOLOGY INC. is believed to be accurate and reliable. However, GENERALPLUS TECHNOLOGY INC. makes no warranty for any errors which may appear in this document. Contact GENERALPLUS TECHNOLOGY INC. to obtain the latest version of device specifications before placing your order. No responsibility is assumed by GENERALPLUS TECHNOLOGY INC. for any infringement of patent or other rights of third parties which may result from its use. In addition, GENERALPLUS products are not authorized for use as critical components in life support systems or aviation systems, where a malfunction or failure of the product may reasonably be expected to result in significant injury to the user, without the express written approval of Generalplus.

Table of Contents

	<u>PAGE</u>
CAPACITIVE TOUCH M-KEY SENSOR	5
1.1 GENERAL DESCRIPTION	5
1.2 FEATURES	5
1.3 PIN CONFIGURATION	6
1.3.1 Pin Description.....	6
1.4 PIN ASSIGNMENT.....	7
1.5 APPLICATION CIRCUIT	7
1.6 APPLICATION SPECIFICATION	8
1.6.1 DC Characteristics (VDD = 5V, TA = 25°C)	8
1.6.2 AC Characteristics (TA = 25°C)	8
1.7 I ² C SERIAL INTERFACE	9
1.8 COMMAND TABLE AND REGISTER MAP	10
1.9 DESIGN GUIDE	13
1.10 PACKAGE	16

REVISION HISTORY

Version	Date	By	Remark
0.1	2014/11/12	henryhsieh	Preliminary Version

CAPACITIVE TOUCH M-KEY SENSOR

1.1 GENERAL DESCRIPTION

GPM8F377A is a capacitive touch sensor with SOC integration to detect the changes of the electric capacitance.

1.2 FEATURES

- Internal oscillator 16MHz \pm 2%
- I/O port with 12mA current sink or drive
- I²C slave interface
- SPI master interface
- Max 7*6 Matrix key
- High noise immunity

1.3 PIN CONFIGURATION

1.3.1 Pin Description

SSOP30:

Pin No	Name	Type	Description
1	NC	--	NC
2	NC	--	NC
3	NC	--	NC
4	SDA	I/O	Serail interface data pin of download regisitor
5	SCK	I/O	Serail interface clock pin of download regisitor
6	NC	--	NC
7	VSS	PWR	System ground
8	NC	--	NC
9	VDD	PWR	System Power
10	NC	--	NC
11	NC	--	NC
12	NC	--	NC
13	NC	--	NC
14	T0	I	Capacitive toucch sensor pin 0
15	/CS	I	Chip Reset pin
16	T1	I	Capacitive toucch sensor pin 1
17	T2	I	Capacitive toucch sensor pin 2
18	T3	I	Capacitive toucch sensor pin 3
19	T4	I	Capacitive toucch sensor pin 4
20	T5	I	Capacitive toucch sensor pin 5
21	T6	I	Capacitive toucch sensor pin 6
22	T7	I	Capacitive toucch sensor pin 7
23	T8	I	Capacitive toucch sensor pin 8
24	T9	I	Capacitive toucch sensor pin 9
25	T10	I	Capacitive toucch sensor pin 10
26	T11	I	Capacitive toucch sensor pin 11
27	T12	I	Capacitive toucch sensor pin 12
28	LED	O	Chip enable dispaly LED
29	I2CSCK	I	I2C interface clock input pin
30	I2CSDA	I/O	I2C interfacer Data input pin

1.4 Pin Assignment

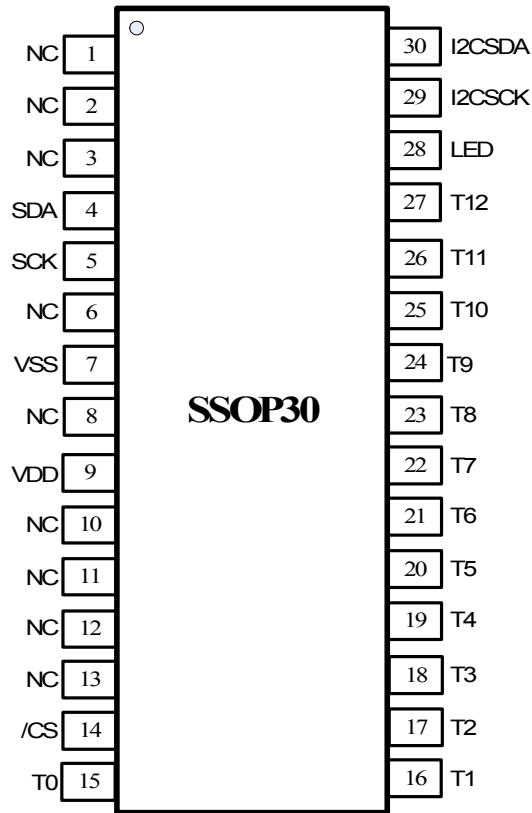

GPM8F377A Package

1.5 Application Circuit

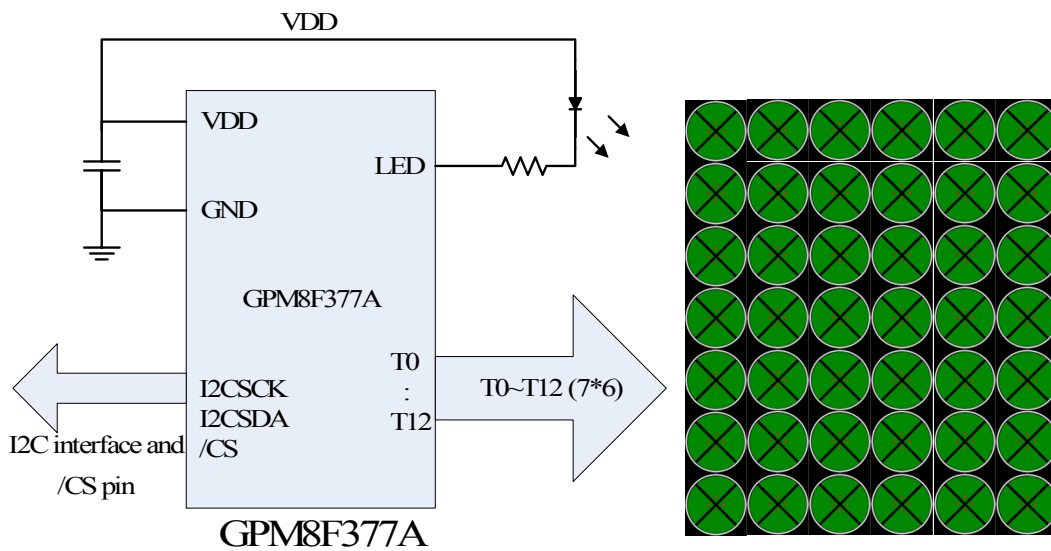

1.6 APPLICATION SPECIFICATION

1.6.1 DC Characteristics (VDD = 5V, TA = 25°C)

Characteristics	Symbol	Limit			Unit	Condition
		Min.	Typ.	Max.		
Operating Voltage	VDD	3.5	5	5.5	V	
Operating Current	IOP	-	5	8	mA	No load at VDD = 5.0V
Standby Current	ISTBY	-	-	8.0	uA	VDD = 5.0V
Input High Level	VIH	0.7VDD	-	-	V	VDD = 5.0V
Input Low Level	VIL	-	-	0.3VDD	V	VDD = 5.0V
Output High Level	VOH	0.8VDD	-	-	V	IOH > -12mA at VDD = 5.0V
Output Low Level	VOL	-	-	0.2VDD	V	IOL > 12mA at VDD = 5.0V

1.6.2 AC Characteristics (TA = 25°C)

Characteristics	Symbol	Limit			Unit	Condition
		Min.	Typ.	Max.		
INOSC Frequency	FOSC	16×(1-2.0%)	16	16×(1+2.0%)	MHz	VDD = 3.5~5.5V

1.7 I²C SERIAL INTERFACE

GPM8F377A features a touch key function, and it will report the touch status through I2C interface. It has I2C slave mode and supports operating speed from 100KHz and up to 400kHz. GPM8F377A is a byte access type and in general, it is designed with commands for special functions as well as commands for register read and write functions.

I²C condition

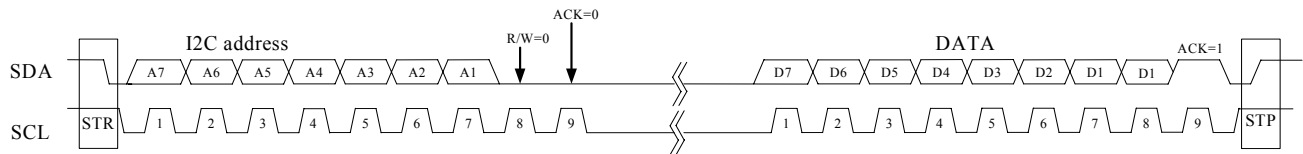

Write command:

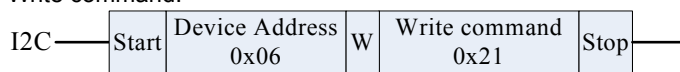

Read Command:

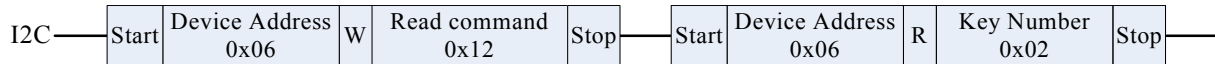

Write Register

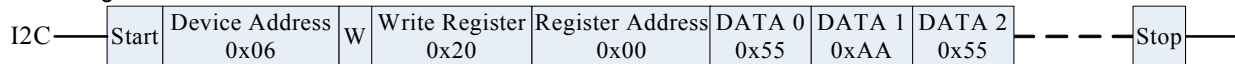

Read Register

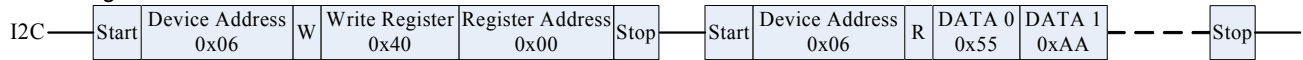

1.8 COMMAND TABLE AND REGISTER MAP

The table below lists the commands used in this document.

Read Command	Name	R/W	Data Type
0x10	Product ID	R	BYTE, Eight bits unsigned integer
0x11	Status	R	BYTE, Bit field
0x12	Key number	R	BYTE, Key number data (00~41)
0x13	Double information	R	BYTE, Key number data (00~230)
0x14	IO information	R	WORD, IO touch information
0x40	Read Register	R	BYTE, Read Register Data

Write Command	Name	R/W	Data Type
0x21	Parameter update	W	Set touch parameter as default.
0x22	Start Touch	W	Start touch function engine.
0x23	Stop Touch	W	Disable touch function engine.
0x20	Write Register	W	BYTE, Write Register Data

Read command status :

0x10	Product ID							
Bit	7	6	5	4	3	2	1	0
Field	PID[7:0]							
Usage	The value in this register cannot be changed. It is used to verify serial communication link.							

0x11	State							
Bit	7	6	5	4	3	2	1	0
Field	SKT_S	SKOT_S	SKF_S	--	--	--	--	--
Usage Bit7 SKT_S	0 = No Key 1 = Finger on key							
Usage Bit6 SKOT_S	0 = Scan time pass 1 = Scan Key over time (when Scan Key over time state occur, Key_Number = 0xFF and if /CS = high system will be reset)							
Usage Bit5 SKF_S	0 = Touch module initialization 1 = Touch module ready							

0x12	Key number							
Bit	7	6	5	4	3	2	1	0
Field	Key_Number[7:0]							
Usage	Key number, Report range 0x01 ~ 0x30 No key pressed : 0x00 Valid complex double key : 0xA0 , Invalid multi key : 0xA1 Key scan over timer : 0xF0							

0x13	Double Key number							
Bit	7	6	5	4	3	2	1	0
Field	Key_Number[7:0]							
Usage	Key number, Report range 00~230, when 0x12 information is 0xA0, check 0x13 will be meaningful.							

0x14	IO touch information (high Byte)							
Bit	7	6	5	4	3	2	1	0
Field	IO number [4:0]							
Usage	Stage for Touch IO status. Stage is defined as IO scan sequence.							

0x14	IO touch information (Low Byte)							
Bit	7	6	5	4	3	2	1	0
Field	IO number [7:0]							
Usage	Stage for Touch IO status. Stage is defined as IO scan sequence.							

Register Map

Capacitance sensor is very sensitive with the environment, temperature, humidity, cover thickness, sensor pad size, and many others. To replace the traditional tact switch with capacitance sensor, not only signal key, but also matrix key can be used. We define the some settings for capacitance sensor touch key development, and the register information is defined as follows.

Register	Name	R/W	Data Type
0x00	TOUCHCON0_Data	R/W	BYTE, Touch IO scan sequence. Reg 0x00 is for first touch scan IO setting, and defined as stage0.
0x0E	Threshold high	R/W	WORD, Touch contact threshold for stage0~stage13, reg 0x1E is for stage0 high byte, 0x0F is stage0 low byte, and so on.
0x2A	Threshold low	R/W	WORD, Touch contact release threshold for stage0~stage13, reg 0x2A is for stage high byte, 0x2B is stage0 low byte, and so on.
0x46	Update threshold	R/W	BYTE, The weight for update baseline for stage0~stage13. Reg 0x46 is for stage0, and so on.
0x54	Noise threshold	R/W	BYTE, The difference between capacitance raw data and base line big than this value, the update mechanism halt for stage0~stage13. Reg 0x54 is for stage0, and so on.
0x62	Debounce count	R/W	BYTE, debounce count for touch key stable output. Reg 0x55 is for stage0, and so on.
0x70	Channel Data	R/W	BYTE, define touch scan IO number, and the same as stage number.
0x71	ScanCount Data	R/W	WORD, Setting capacitance Touch IO charge times.
0x73	Update Timer	R/W	BYTE, Setting timer 0 for Touch data update interval time.
0x76	Wakeup count	R/W	WORD,
0x78	Filter Buffer size	R/W	BYTE,
0x79	Display	RW	BYTE,
0x87	XAxis line	R/W	BYTE, X-axis number of matrix key.
0x88	YAxis Line	R/W	BYTE, Y-axis number of matrix key.
0x89	Axis position data	R/W	BYTE, X and Y axis position information for matrix key use, X-axis and Y-axis position is setting by order.

Register	Name	R/W	Data Type
0x97~0x9F		R/W	Reserved.
0xA0~0xBB	Cap data Buffer	R	WORD, define the touch capacitance raw data. Reg 0xA0 is for stage0 high byte; 0xA1 is stage0 low byte, and so on.
0xBC~0xD7	Baseline data buffer	R	WORD, define the touch capacitance baseline data. Reg 0xBC is for stage0 high byte; 0xBD is stage0 low byte, and so on.
0xD8~0xF3	Difference data	R	WORD, define the touch difference count between raw data and baseline data. Reg 0xD8 is for stage0 high byte, 0xB9 is stage0 low byte, and so on.
0xF4~0xFF		R	Reserved.

1.9 DESIGN GUIDE

GPM8F377A has maximum of 13 capacitance-touch sensor I/Os, and for advance use, it can be programmed as a matrix key function. When GPM8F377A is programmed a matrix key function, it can form maximum of 42 single keys. For some special cases, it has complex double key function. In planning stage, user should first define the number of x-axis and y-axis needed. For complex double key, it will be two x-axis and one y-axis, or two y-axis and one x-axis, similar to the layout diagrams given below. Then, user must define the position of complex double key, and GPM8F377A will report the mapping key data for this position.

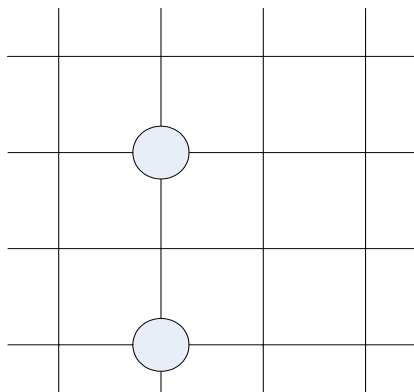

Fig -1 Valid complex double key definition

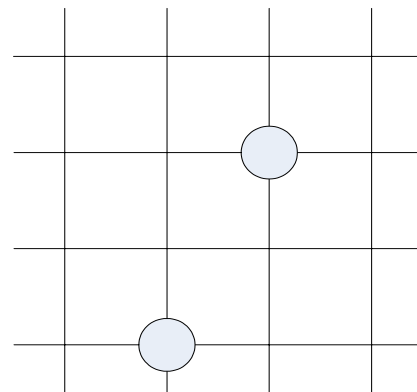

Fig -2 Invalid key definition

To make GPM8F377A design more easily and communication with other devices more convenient, we design it with I2C command to get capacitance touch information. In general, user only needs to issue commands, 0x10, 0x11, and 0x12, to get IC vender code and key information, and command 0x13 to get complex double key information. Please refer to Fig-3 for more details about the operation flow. Furthermore, we also design commands to read and write register. GPM8F377A firmware code flow is: when it is powered on, IC will load some major touch parameters from flash memory to register, and it will perform firmware processes via the register, and when a touch event occurs, it will report host through I2C interface. In mass production stage, user may encounter the problems of material change or thickness change to the covers, which may make the touch sensitivity worse. For advance users, they can get the touch information through their own host platforms, and update the parameters to register and re-check the touch sensitivity settings. Repeat the check flow, suitable value can be acquired for touch sensitivity settings, and ultimately, restore the register parameter to Flash memory in default.

Host platform normal check touch key function operation flow is as follows:

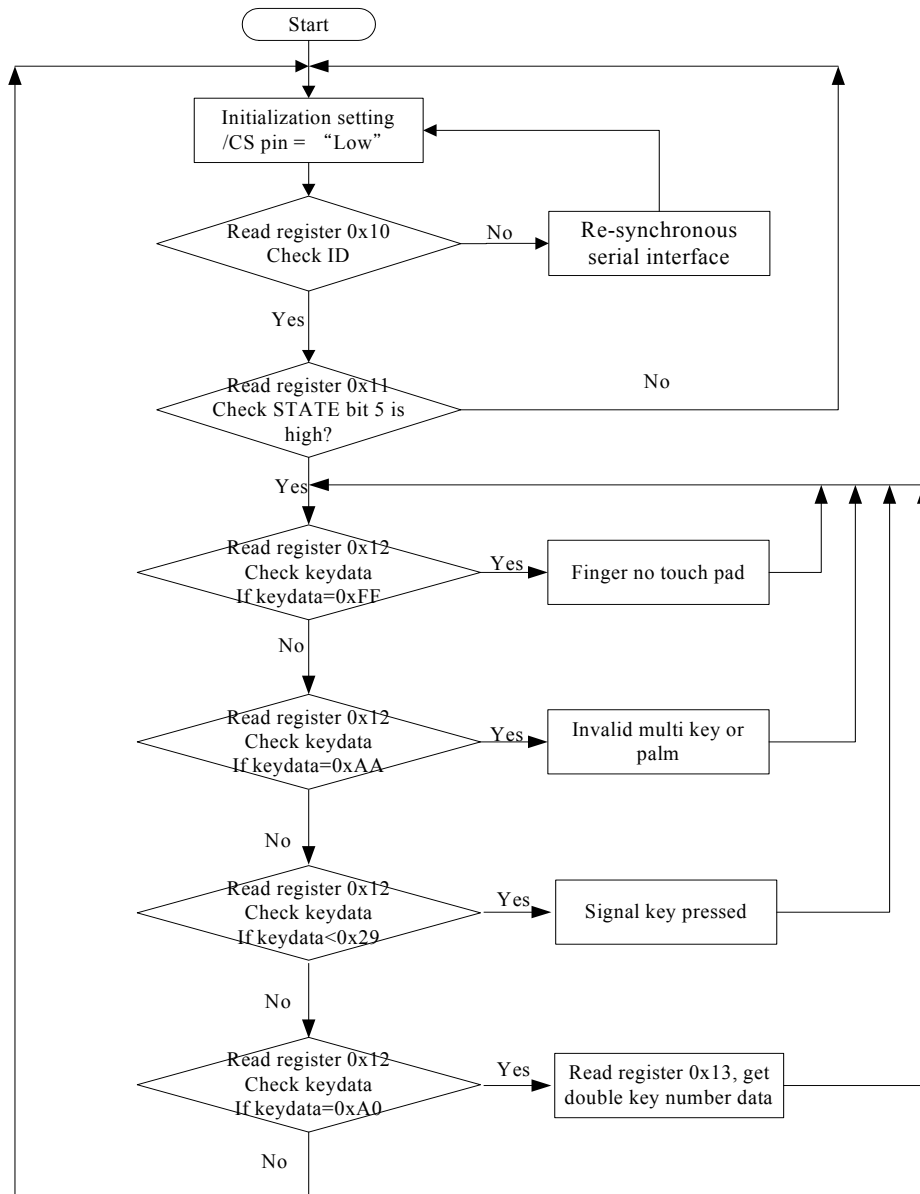

Fig - 3

Parameter Check and update flow

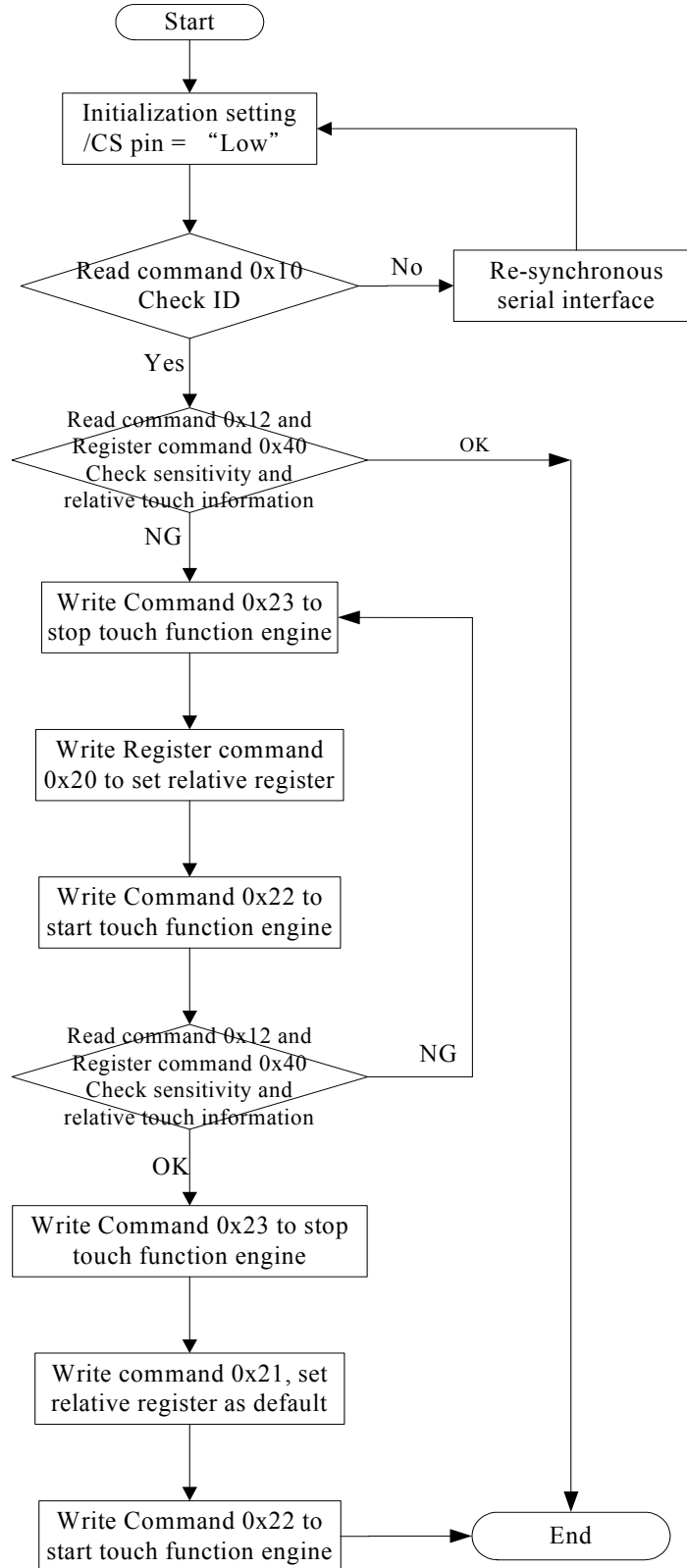
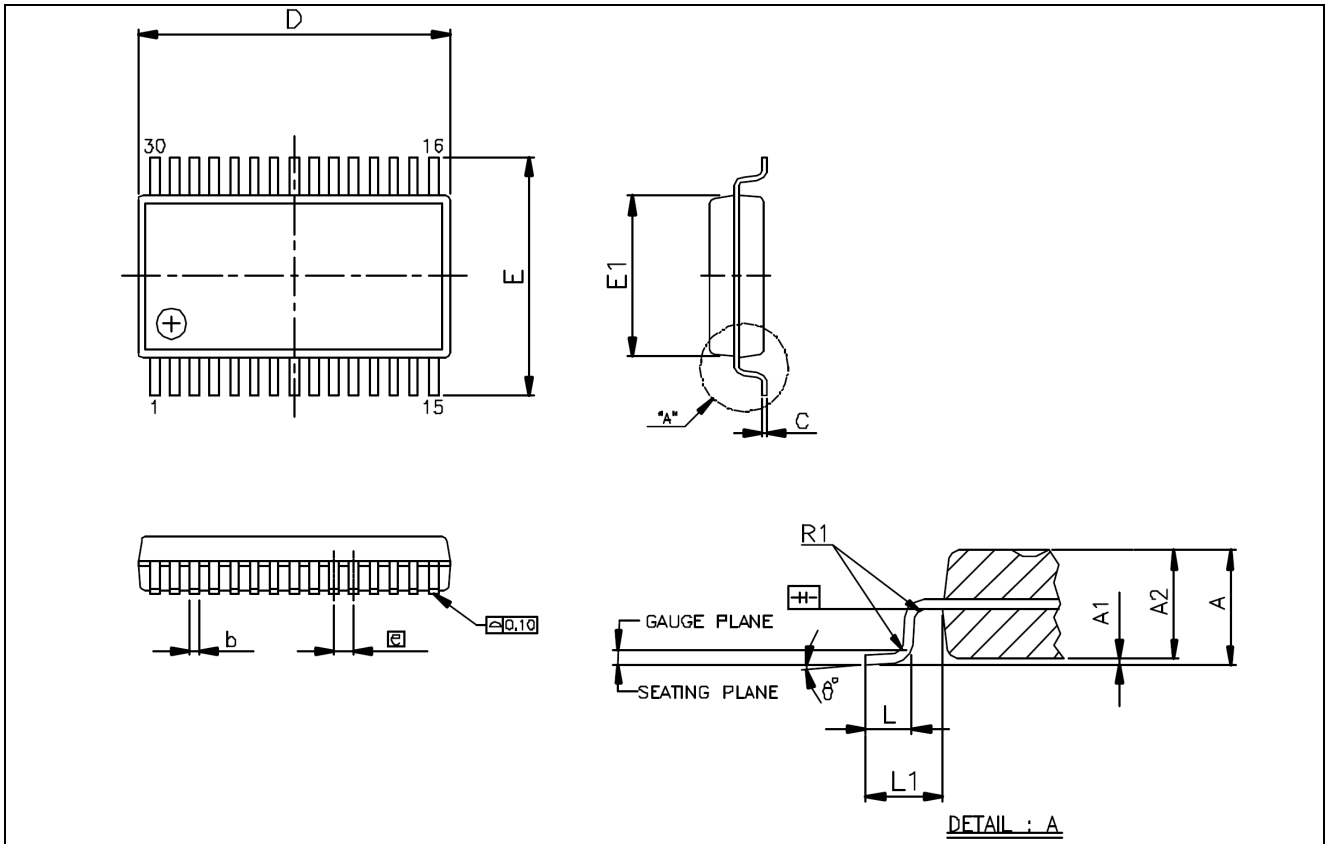

Fig - 4

1.10 PACKAGE



Symbol	Millimeter		
	Min.	Nom.	Max.
A	--	--	2.0
A1	0.05	--	--
A2	1.65	1.75	1.85
b	0.22	--	0.38
c	0.09	--	0.21
D	9.90	10.20	10.50
E	7.40	7.80	8.20
E1	5.00	5.30	5.60
e	0.65 BSC		
L	0.55	0.75	0.95
L1	1.25 REF		
R1	0.09	--	--
θ°	0°	4°	8°