

GENERAL DESCRIPTION

The single-chip ICM-30630 is the world's first tri-core 6-axis motion tracking solution with integrated sensor-hub framework software. It combines industry leading gyroscope and accelerometer sensors with tri-core processors (an ARM Cortex-M0 CPU, a DMP3 and a DMP4 Digital Motion Processor™) in a small 3x3x1mm LGA package.

The ICM-30630 serves as a sensor hub that supports the collection and processing of data from internal and external sensors. The multi-cores are designed to offload processing from the Application Processor, thereby saving system power and improving performance.

The ARM Cortex-M0 CPU provides a low-power programmable platform for software development. The DMP3 offloads Android L processing from the CPU and provides ready-to-use physical and virtual Android sensors. The DMP4 is optimized for fixed point processing and FFT generation and complements the CPU by offloading math intensive operations.

The integrated InvenSense Sensor Framework provides an open and powerful platform for creating cutting-edge always-on applications for mobile platforms. Developers can use the built-in framework components to rapidly develop and launch new features. The command protocol is designed for seamless porting to new systems, allowing software reuse and thus maximizing returns on software investment.

BLOCK DIAGRAM

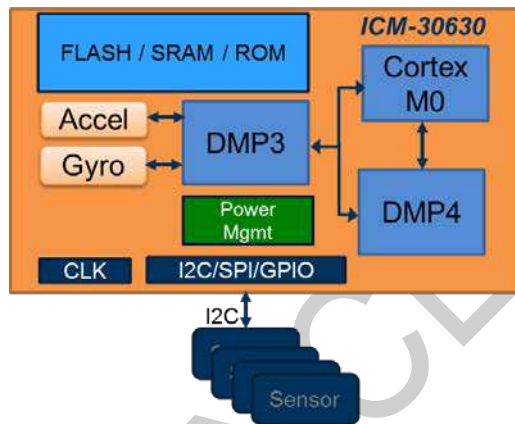

SENSOR FRAMEWORK SOFTWARE

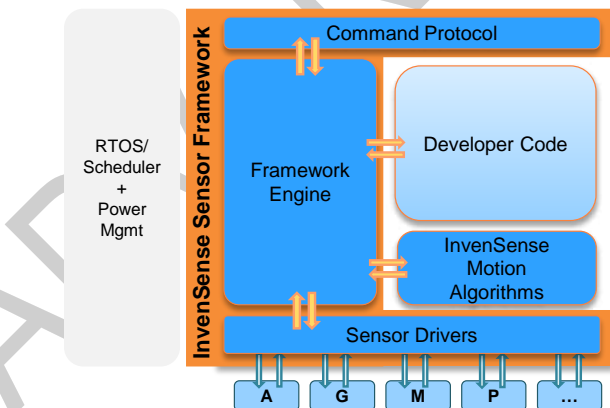

APPLICATIONS

- Smartphones and Tablets
- Wearables

FEATURES

- Tri-core sensor hub with integrated 6-Axis in a 24-Pin LGA: 3mm x 3mm x 1mm package
- Built-in sensor framework for fast time-to-market
- Low Power 6-Axis Device:
 - 2.25mW 6-Axis Power (Gyro+Accel 102.3Hz ODR)
- Android L Support
- On-Chip Runtime Calibration
- Auxiliary I²C interface to support additional sensors, enabling multi-sensor MotionFusion operation
- 3-Axis Gyroscope with Programmable FSR of ±250, ±500, ±1000, and ±2000dps
- 3-Axis Accelerometer with Programmable FSR of ±2g, ±4g, ±8g and ±16g
- ARM Cortex-M0 CPU & DMP3 and DMP4
- Flash 64Kbytes
- SRAM 64Kbytes (shared by Cortex-M0, DMPs, FIFO)
- DMA Controller
- 4 timers that can be used for timestamp, watchdog, and general purpose timer functions
- Serial Wire Data Port for Cortex-M0 debug/trace
- 3 on-chip oscillators for system clock, accurate time stamping, and periodic wakeup
- 3 GPIO bidirectional pins configurable as general purpose input/output, or interrupt input/output
- I²C up to 2.7MHz; SPI up to 6.4MHz

TYPICAL OPERATING CIRCUIT

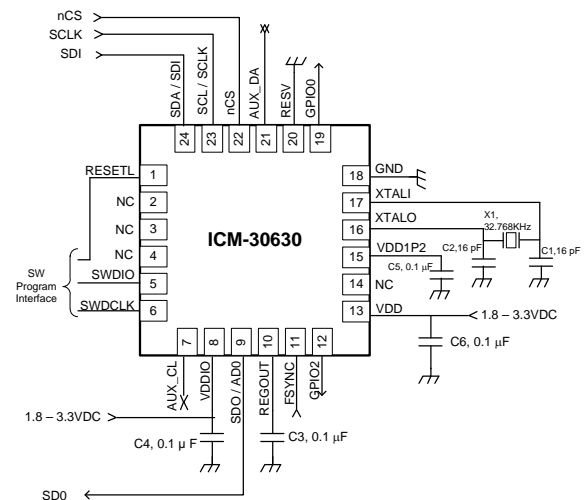

ORDERING INFORMATION

PART	TEMP RANGE	PACKAGE
ICM-30630†	-40°C to +85°C	24-Pin LGA

†Denotes RoHS and Green-Compliant Package