

Multi-Sensor High Accuracy Digital Temperature Measurement System

FEATURES

- Directly Digitize RTDs, Thermocouples, Thermistors and Diodes
- Single 2.85V to 5.25V Supply
- Results Reported in °C or °F
- 20 Flexible Inputs Allow Interchanging Sensors
- Automatic Thermocouple Cold Junction Compensation
- Built-In Standard and User-Programmable Coefficients for Thermocouples, RTDs and Thermistors
- Configurable 2-, 3- or 4-Wire RTD Configurations
- Measures Negative Thermocouple Voltages
- Automatic Burn Out, Short-Circuit and Fault Detection
- Buffered Inputs Allow External Protection
- Simultaneous 50Hz/60Hz Rejection
- Includes 15ppm/°C (Max) Reference (I-Grade)

APPLICATIONS

- Direct Thermocouple Measurements
- Direct RTD Measurements
- Direct Thermistor Measurements
- Custom Sensor Applications

DESCRIPTION

The **LTC®2983** measures a wide variety of temperature sensors and digitally outputs the result, in °C or °F, with 0.1°C accuracy and 0.001°C resolution. The LTC2983 can measure the temperature of virtually all standard (type B, E, J, K, N, S, R, T) or custom thermocouples, automatically compensate for cold junction temperatures and linearize the results. The device can also measure temperature with standard 2-, 3- or 4-wire RTDs, thermistors and diodes. It has 20 reconfigurable analog inputs enabling many sensor connections and configuration options. The LTC2983 includes excitation current sources and fault detection circuitry appropriate for each type of temperature sensor.

The LTC2983 allows direct interfacing to ground referenced sensors without the need for level shifters, negative supply voltages, or external amplifiers. All signals are buffered and simultaneously digitized with three high accuracy, 24-bit $\Delta\Sigma$ ADCs, driven by an internal 15ppm/°C (maximum) reference.

LT, LT, LTC, LTM, Linear Technology and the Linear logo are registered trademarks of Linear Technology Corporation. All other trademarks are the property of their respective owners. Patents Pending

TYPICAL APPLICATION

Thermocouple Measurement with Automatic Cold Junction Compensation

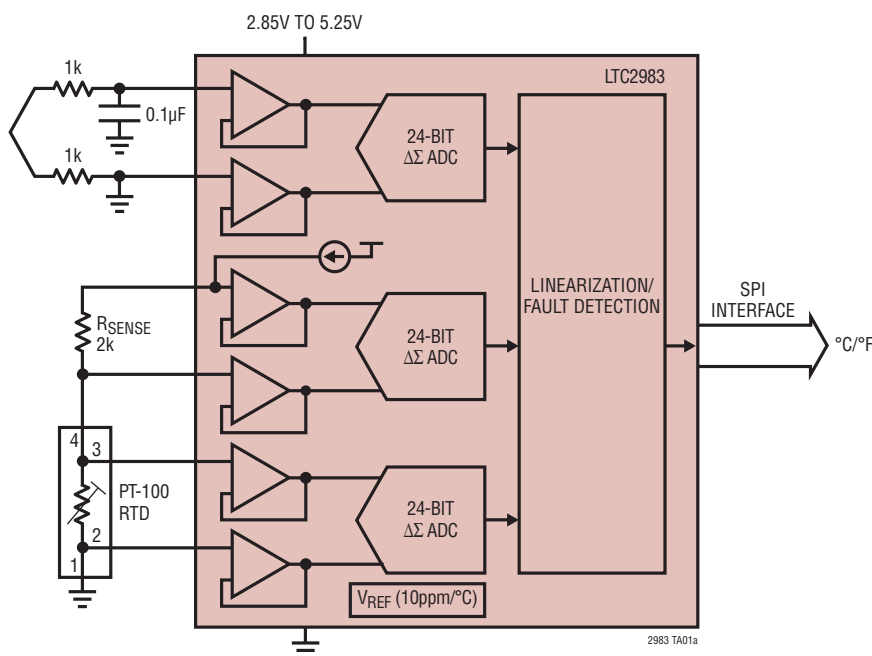

Typical Temperature Error Contribution

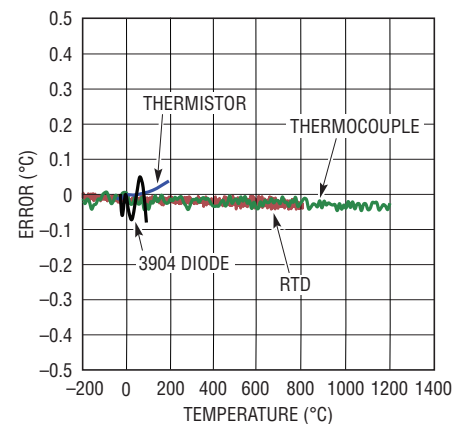

2983 TA01b

TABLE OF CONTENTS

| | |
|---|-----------|
| Features | 1 |
| Applications | 1 |
| Typical Application | 1 |
| Description..... | 1 |
| Absolute Maximum Ratings..... | 3 |
| Order Information | 3 |
| Complete System Electrical Characteristics..... | 3 |
| Pin Configuration | 3 |
| ADC Electrical Characteristics | 4 |
| Reference Electrical Characteristics..... | 4 |
| Digital Inputs and Digital Outputs | 5 |
| Typical Performance Characteristics | 6 |
| Pin Functions | 9 |
| Block Diagram..... | 10 |
| Test Circuits | 11 |
| Timing Diagram..... | 11 |
| Overview | 12 |
| Applications Information | 16 |
| Thermocouple Measurements | 21 |
| Diode Measurements..... | 24 |
| RTD Measurements | 28 |
| Thermistor Measurements..... | 43 |
| Direct ADC Measurements..... | 55 |
| Supplemental Information..... | 55 |
| Fault Protection and Anti-Aliasing..... | 57 |
| 2- and 3-Cycle Conversion Modes..... | 57 |
| Running Conversions Consecutively on Multiple Channels..... | 58 |
| MUX Configuration Delay..... | 58 |
| Global Configuration Register..... | 59 |
| Custom Thermocouples | 59 |
| Custom RTDs | 62 |
| Custom Thermistors | 65 |
| Package Description | 70 |
| Revision History | 71 |
| Typical Application | 72 |
| Related Parts | 72 |

ABSOLUTE MAXIMUM RATINGS

(Notes 1, 2)

| | |
|--|------------------------------|
| Supply Voltage (V_{DD}) | -0.3V to 6V |
| Analog Input Pins (CH1 to CH20, COM) | -0.3V to ($V_{DD} + 0.3V$) |
| Input Current (CH1 to CH20, COM) | $\pm 15mA$ |
| Digital Inputs (\overline{CS} , SDI, SCK, \overline{RESET}) | -0.3V to ($V_{DD} + 0.3V$) |
| Digital Outputs (SDO, INTERRUPT) | -0.3V to ($V_{DD} + 0.3V$) |
| V_{REFP} | -0.3V to 2.8V |
| Q_1 , Q_2 , Q_3 , LDO, V_{REFOUT} , V_{REF_BVP} (Note 17) | |
| Reference Short-Circuit Duration | Indefinite |
| Operating Temperature Range | |
| LTC2983C | 0°C to 70°C |
| LTC2983I | -40°C to 85°C |

PIN CONFIGURATION

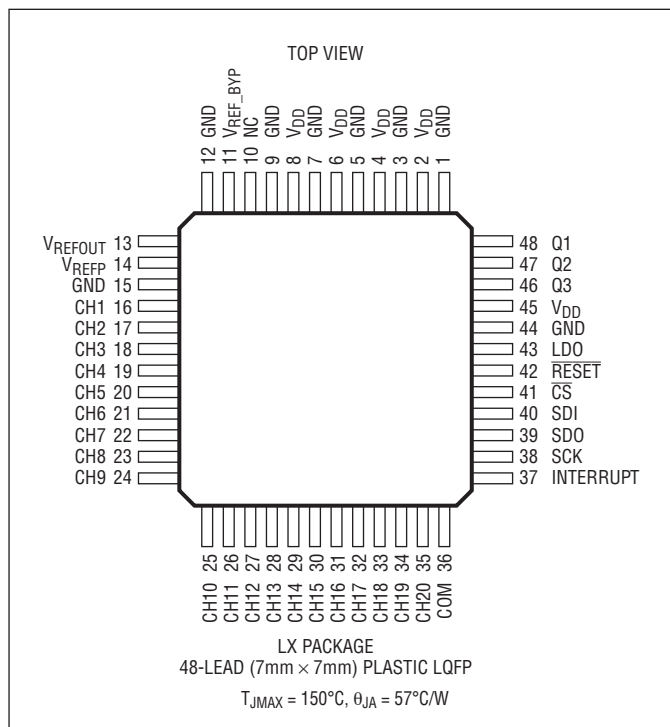

ORDER INFORMATION

| LEAD FREE FINISH | TRAY | PART MARKING* | PACKAGE DESCRIPTION | TEMPERATURE RANGE |
|------------------|----------------|---------------|--------------------------|-------------------|
| LTC2983CLX#PBF | LTC2983CLX#PBF | LTC2983 | 48-Lead (7mm × 7mm) LQFP | 0°C to 70°C |
| LTC2983ILX#PBF | LTC2983ILX#PBF | LTC2983 | 48-Lead (7mm × 7mm) LQFP | -40°C to 85°C |

Consult LTC Marketing for parts specified with wider operating temperature ranges. *The temperature grade is identified by a label on the shipping container. For more information on lead free part marking, go to: <http://www.linear.com/leadfree/>

COMPLETE SYSTEM ELECTRICAL CHARACTERISTICS

The ● denotes the specifications which apply over the full operating temperature range, otherwise specifications are at $T_A = 25^\circ C$.

| PARAMETER | CONDITIONS | MIN | TYP | MAX | UNITS |
|-----------------------------|--|-------|-----|----------------|---------|
| Supply Voltage | ● | 2.85 | | 5.25 | V |
| Supply Current | ● | | 15 | 20 | mA |
| Sleep Current | ● | | 25 | 60 | μA |
| Input Range | All Analog Input Channels ● | -0.05 | | $V_{DD} - 0.3$ | V |
| Output Rate | Two Conversion Cycle Mode (Notes 6, 9) ● | 150 | 164 | 170 | ms |
| Output Rate | Three Conversion Cycle Mode (Notes 6, 9) ● | 225 | 246 | 255 | ms |
| Input Common Mode Rejection | 50Hz/60Hz (Note 4) ● | 120 | | | dB |
| Input Normal Mode Rejection | 60Hz (Notes 4, 7) ● | 120 | | | dB |

COMPLETE SYSTEM ELECTRICAL CHARACTERISTICS

The ● denotes the specifications which apply over the full operating temperature range, otherwise specifications are at $T_A = 25^\circ\text{C}$.

| PARAMETER | CONDITIONS | | MIN | TYP | MAX | UNITS |
|-----------------------------|---------------------------|---|-----|------|-----|-------|
| Input Normal Mode Rejection | 50Hz (Notes 4, 8) | ● | 120 | | | dB |
| Input Normal Mode Rejection | 50Hz/60Hz (Notes 4, 6, 9) | ● | 75 | | | dB |
| Power-On Reset Threshold | | | | 2.25 | | V |
| Analog Power-Up | (Note 11) | ● | | | 100 | ms |
| Digital Initialization | (Note 12) | ● | | | 100 | ms |

ADC ELECTRICAL CHARACTERISTICS

The ● denotes the specifications which apply over the full operating temperature range, otherwise specifications are at $T_A = 25^\circ\text{C}$.

| PARAMETER | CONDITIONS | | MIN | TYP | MAX | UNITS |
|---------------------------------|---------------------------------------|---|---------------------------------|----------|----------------|---------------------------------|
| Resolution (No Missing Codes) | $-F_S \leq V_{IN} \leq +F_S$ | ● | 24 | | | Bits |
| Integral Nonlinearity | $V_{IN(CM)} = 1.25\text{V}$ (Note 15) | ● | | 2 | 30 | ppm of V_{REF} |
| Offset Error | | ● | | 0.5 | 2 | μV |
| Offset Error Drift | (Note 4) | ● | | 10 | 20 | $\text{nV}/^\circ\text{C}$ |
| Positive Full-Scale Error | (Notes 3, 15) | ● | | | 100 | ppm of V_{REF} |
| Positive Full-Scale Drift | (Notes 3, 15) | ● | | 0.1 | 0.5 | ppm of $V_{REF}/^\circ\text{C}$ |
| Input Leakage | (Note 18) | ● | | | 1 | nA |
| Negative Full-Scale Error | (Notes 3, 15) | ● | | | 100 | ppm of V_{REF} |
| Negative Full-Scale Drift | (Notes 3, 15) | ● | | 0.1 | 0.5 | ppm of $V_{REF}/^\circ\text{C}$ |
| Output Noise | (Note 5) | ● | | 0.8 | 1.5 | μV_{RMS} |
| Common Mode Input Range | | ● | -0.05 | | $V_{DD} - 0.3$ | V |
| RTD Excitation Current | (Note 16) | ● | -25 | Table 30 | 25 | % |
| RTD Excitation Current Matching | Continuously Calibrated | ● | Error within Noise Level of ADC | | | |
| Thermistor Excitation Current | (Note 16) | ● | -37.5 | Table 53 | 37.5 | % |

REFERENCE ELECTRICAL CHARACTERISTICS

The ● denotes the specifications which apply over the full operating temperature range, otherwise specifications are at $T_A = 25^\circ\text{C}$.

| PARAMETER | CONDITIONS | | MIN | TYP | MAX | UNITS |
|---|--|---|------|-----|------|--------------------------|
| Output Voltage | V_{REFOUT} (Note 10) | | 2.49 | | 2.51 | V |
| Output Voltage Temperature Coefficient | I-Grade | ● | | 3 | 15 | ppm/ $^\circ\text{C}$ |
| Output Voltage Temperature Coefficient | C-Grade | ● | | 3 | 20 | ppm/ $^\circ\text{C}$ |
| Line Regulation | | ● | | | 10 | ppm/V |
| Load Regulation | $I_{OUT(SOURCE)} = 100\mu\text{A}$ | ● | | | 5 | mV/mA |
| | $I_{OUT(SINK)} = 100\mu\text{A}$ | ● | | | 5 | mV/mA |
| Output Voltage Noise | $0.1\text{Hz} \leq f \leq 10\text{Hz}$ | | | 4 | | μV_{P-P} |
| | $10\text{Hz} \leq f \leq 1\text{kHz}$ | | | 4.5 | | μV_{P-P} |
| Output Short-Circuit Current | Short V_{REFOUT} to GND | | | 40 | | mA |
| | Short V_{REFOUT} to V_{DD} | | | 30 | | mA |
| Turn-On Time | 0.1% Setting, $C_{LOAD} = 1\mu\text{F}$ | | | 115 | | μs |
| Long Term Drift of Output Voltage (Note 13) | | | | 60 | | ppm/ $\sqrt{\text{kHz}}$ |
| Hysteresis (Note 14) | $\Delta T = 0^\circ\text{C}$ to 70°C | | | 30 | | ppm |
| | $\Delta T = -40^\circ\text{C}$ to 85°C | | | 70 | | ppm |

DIGITAL INPUTS AND DIGITAL OUTPUTS

full operating temperature range, otherwise specifications are at $T_A = 25^\circ\text{C}$.

The ● denotes the specifications which apply over the

| SYMBOL | PARAMETER | CONDITIONS | MIN | TYP | MAX | UNITS |
|--------|--|--|-----|-----------------------|-----|---------------|
| | External SCK Frequency Range | | ● | 0 | 2 | MHz |
| | External SCK LOW Period | | ● | 250 | | ns |
| | External SCK HIGH Period | | ● | 250 | | ns |
| t_1 | $\overline{\text{CS}}\downarrow$ to SDO Valid | | ● | 0 | 200 | ns |
| t_2 | $\overline{\text{CS}}\uparrow$ to SDO Hi-Z | | ● | 0 | 200 | ns |
| t_3 | $\overline{\text{CS}}\downarrow$ to SCK \uparrow | | ● | 100 | | ns |
| t_4 | SCK \downarrow to SDO Valid | | ● | | 225 | ns |
| t_5 | SDO Hold After SCK \downarrow | | ● | 10 | | ns |
| t_6 | SDI Setup Before SCK \uparrow | | ● | 100 | | ns |
| t_7 | SDI HOLD After SCK \uparrow | | ● | 100 | | ns |
| | High Level Input Voltage | $\overline{\text{CS}}$, SDI, SCK, $\overline{\text{RESET}}$ | ● | $V_{\text{DD}} - 0.5$ | | V |
| | Low Level Input Voltage | $\overline{\text{CS}}$, SDI, SCK, $\overline{\text{RESET}}$ | ● | | 0.5 | V |
| | Digital Input Current | $\overline{\text{CS}}$, SDI, SCK, $\overline{\text{RESET}}$ | ● | -10 | 10 | μA |
| | Digital Input Capacitance | $\overline{\text{CS}}$, SDI, SCK, $\overline{\text{RESET}}$ | | 10 | | pF |
| | LOW Level Output Voltage (SDO, INTERRUPT) | $I_O = -800\mu\text{A}$ | ● | | 0.4 | V |
| | High Level Output Voltage (SDO, INTERRUPT) | $I_O = 1.6\text{mA}$ | ● | $V_{\text{DD}} - 0.5$ | | V |
| | Hi-Z Output Leakage (SDO) | | ● | -10 | 10 | μA |

Note 1: Stresses beyond those listed under Absolute Maximum Ratings may cause permanent damage to the device. Exposure to any Absolute Maximum Rating condition for extended periods may affect device reliability and lifetime.

Note 2: All voltage values are with respect to GND.

Note 3: Full scale ADC error. Measurements do not include reference error.

Note 4: Guaranteed by design, not subject to test.

Note 5: The output noise includes the contribution of internal calibration operations.

Note 6: MUX configuration delay = default 1ms

Note 7: Global configuration set to 60Hz rejection.

Note 8: Global configuration set to 50Hz rejection.

Note 9: Global configuration default 50Hz/60Hz rejection.

Note 10: The exact value of V_{REF} is stored in the LTC2983 and used for all measurement calculations. Temperature coefficient is measured by dividing the maximum change in output voltage by the specified temperature range.

Note 11: Analog power-up. Command status register inaccessible during this time.

Note 12: Digital initialization. Begins at the conclusion of Analog Power-Up. Command status register is 0×80 at the beginning of digital initialization and 0×40 at the conclusion.

Note 13: Long-term stability typically has a logarithmic characteristic and therefore, changes after 1000 hours tend to be much smaller than before that time. Total drift in the second thousand hours is normally less

than one third that of the first thousand hours with a continuing trend toward reduced drift with time. Long-term stability will also be affected by differential stresses between the IC and the board material created during board assembly.

Note 14: Hysteresis in output voltage is created by package stress that differs depending on whether the IC was previously at a higher or lower temperature. Output voltage is always measured at 25°C , but the IC is cycled to the hot or cold temperature limit before successive measurements. Hysteresis measures the maximum output change for the averages of three hot or cold temperature cycles. For instruments that are stored at well controlled temperatures (within 20 or 30 degrees of operational temperature), it is usually not a dominant error source. Typical hysteresis is the worst-case of 25°C to cold to 25°C or 25°C to hot to 25°C , preconditioned by one thermal cycle.

Note 15: Differential Input Range is $\pm V_{\text{REF}}/2$.

Note 16: RTD and thermistor measurements are made ratiometrically. As a result current source excitation variation does not affect absolute accuracy. Choose an excitation current such that largest sensor or R_{SENSE} resistance value, when driven by the nominal excitation current, will drop 1V or less. The extended ADC input range will accommodate variation in excitation current and the ratiometric calculation will negate the absolute value of the excitation current.

Note 17: Do not apply voltage or current sources to these pins. They must be connected to capacitive loads only, otherwise permanent damage may occur.

Note 18: Input leakage measured with $V_{\text{IN}} = -10\text{mV}$ and $V_{\text{IN}} = 2.5\text{V}$.

TYPICAL PERFORMANCE CHARACTERISTICS

Type J Thermocouple Error and RMS Noise vs Temperature

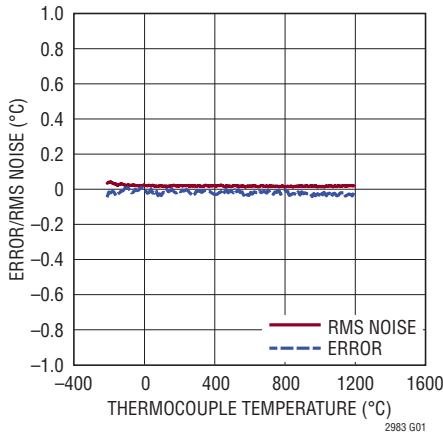

Type K Thermocouple Error and RMS Noise vs Temperature

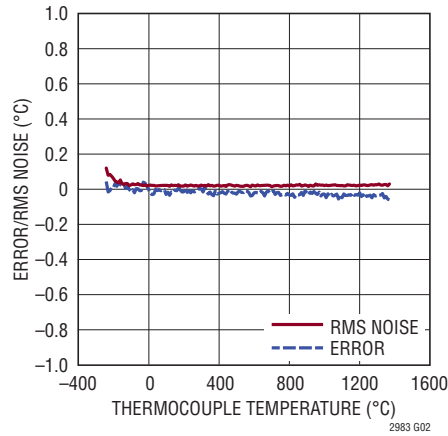

Type N Thermocouple Error and RMS Noise vs Temperature

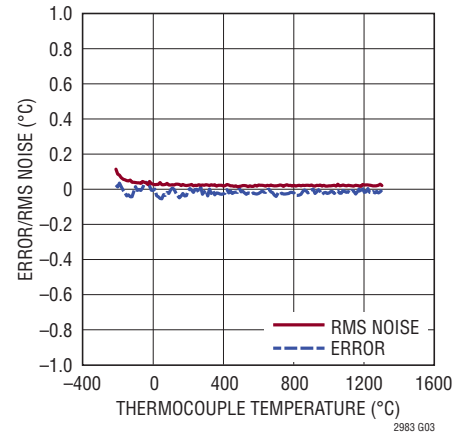

Type R Thermocouple Error and RMS Noise vs Temperature

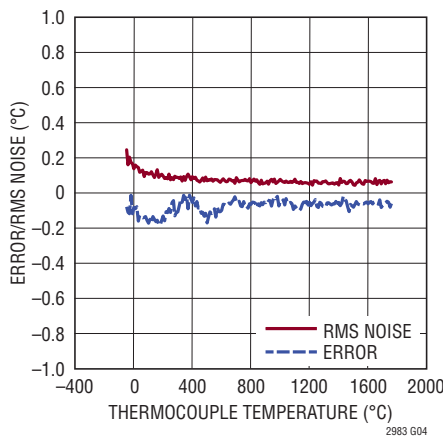

Type S Thermocouple Error and RMS Noise vs Temperature

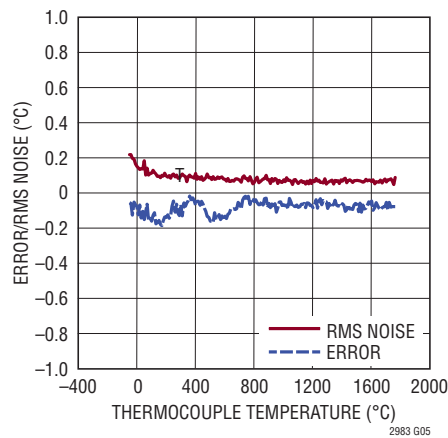

Type T Thermocouple Error and RMS Noise vs Temperature

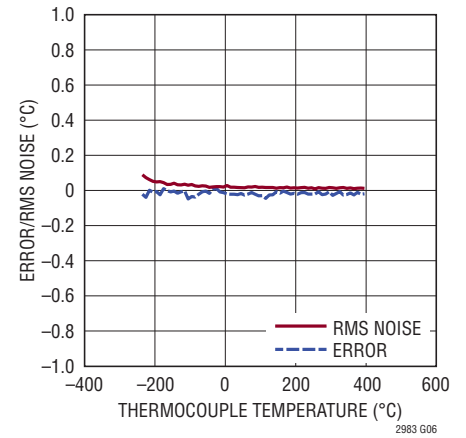

Type E Thermocouple Error and RMS Noise vs Temperature

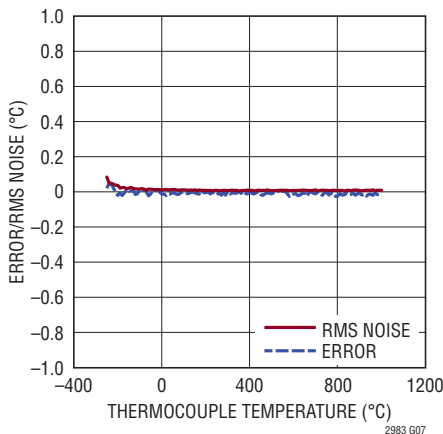

Type B Thermocouple Error and RMS Noise vs Temperature

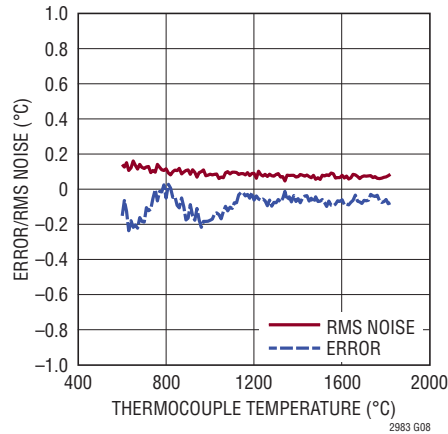

RTD PT-1000 Error and RMS Noise vs Temperature

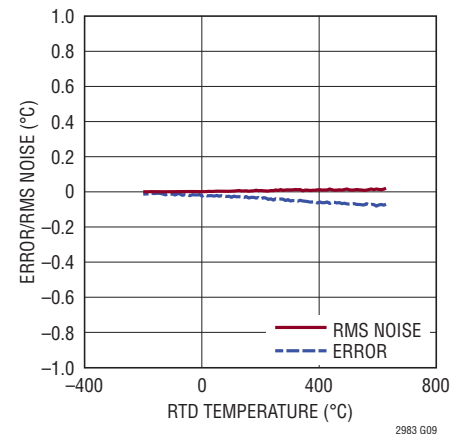

TYPICAL PERFORMANCE CHARACTERISTICS

RTD PT-200 Error and RMS Noise vs Temperature

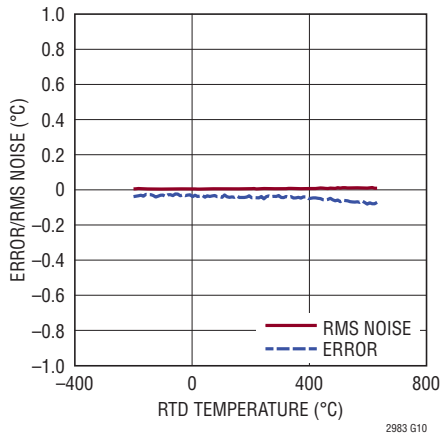

RTD PT-100 Error and RMS Noise vs Temperature

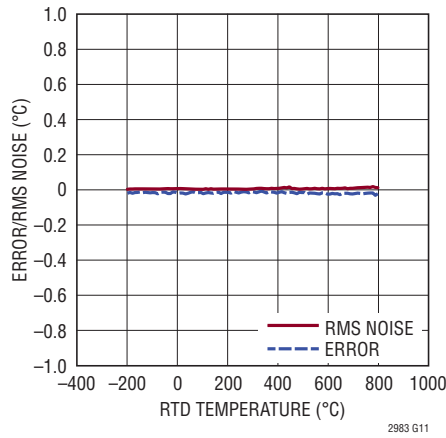

RTD NI-120 RTD Error and RMS Noise vs Temperature

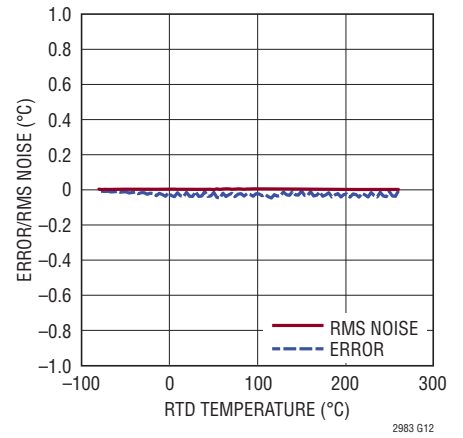

2.252k Thermistor Error vs Temperature

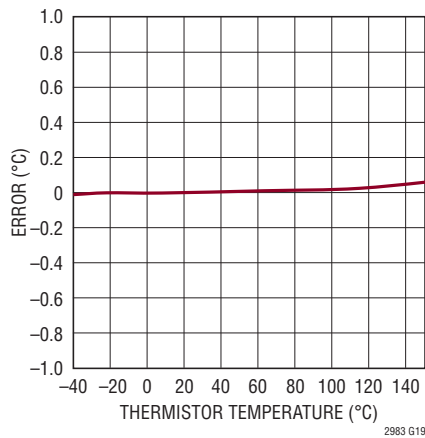

3k Thermistor Error vs Temperature

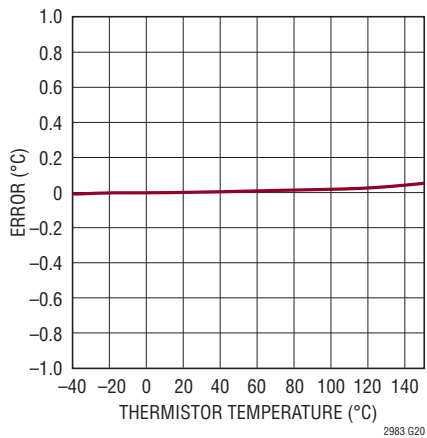

5k Thermistor Error vs Temperature

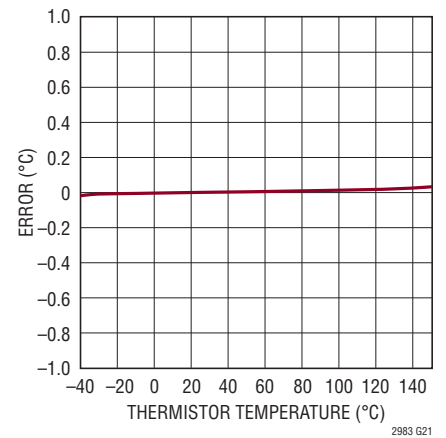

10k Thermistor Error vs Temperature

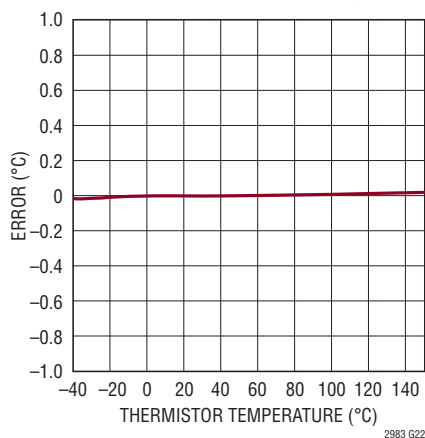

30k Thermistor Error vs Temperature

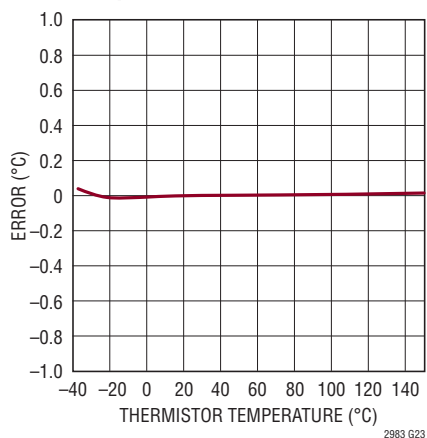

YSI-400 Thermistor Error vs Temperature

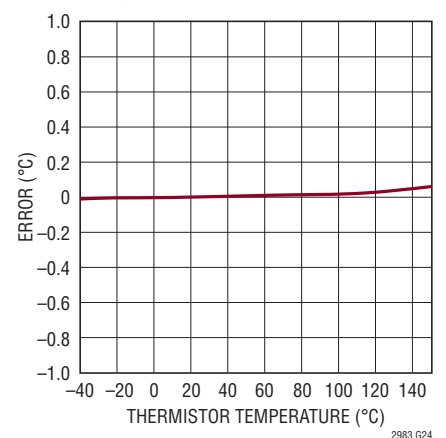

TYPICAL PERFORMANCE CHARACTERISTICS

Diode Error and Repeatability vs Temperature

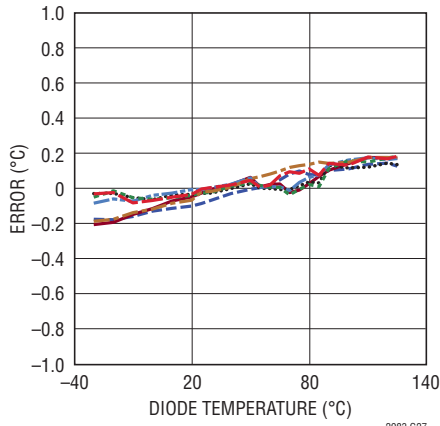

Offset vs Temperature

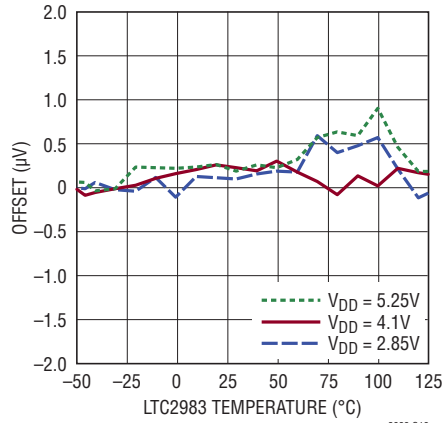

Noise vs Temperature

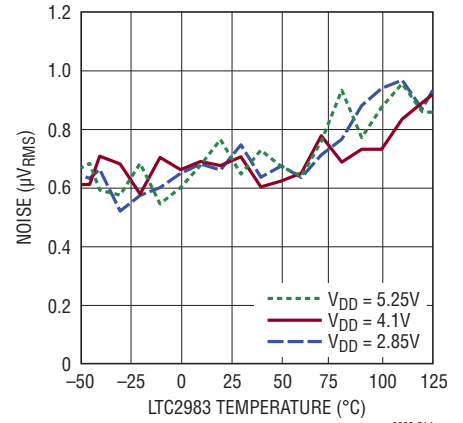

I_{SLEEP} vs Temperature

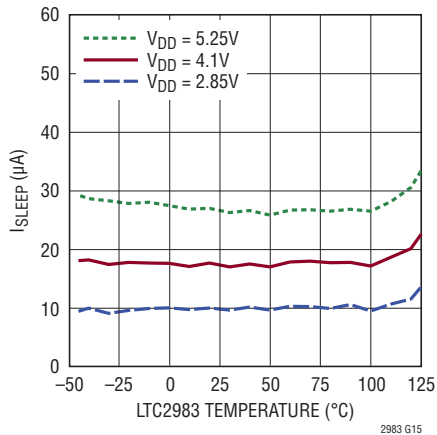

One Shot Conversion Current vs Temperature

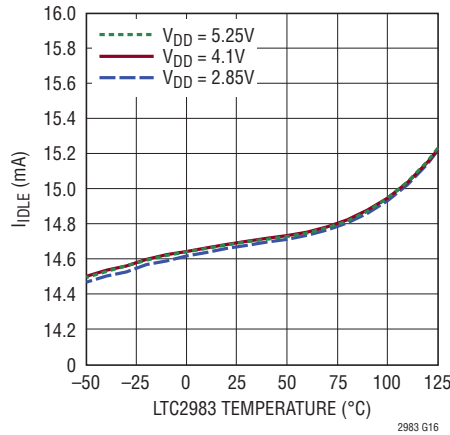

V_{REF(OUT)} vs Temperature

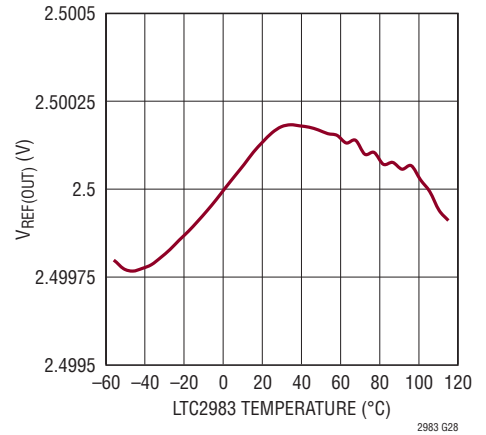

Channel Input Leakage Current vs Temperature

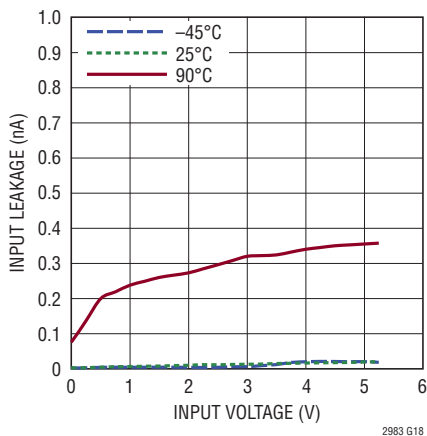

Adjacent Channel Offset Error vs Input Fault Voltage (V_{DD} = 5V)

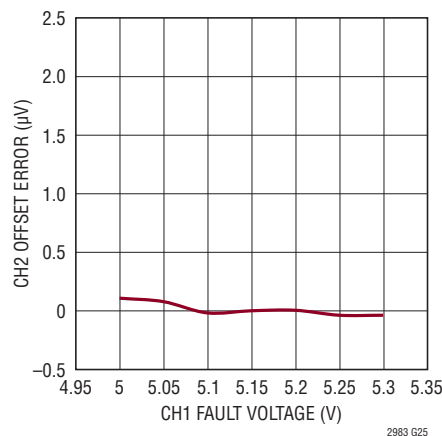

Adjacent Channel Offset Error vs Input Fault Voltage

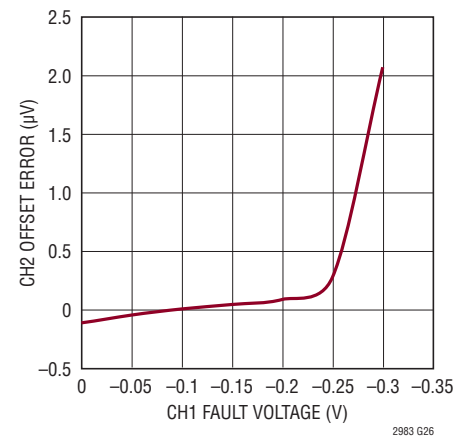

PIN FUNCTIONS

GND (Pins 1, 3, 5, 7, 9, 12, 15, 44): Ground. Connect each of these pins to a common ground plane through a low impedance connection. All eight pins must be grounded for proper operation.

V_{DD} (Pins 2, 4, 6, 8, 45): Analog Power Supply. Tie all five pins together and bypass as close as possible to the device, to ground with a 0.1 μ F capacitor.

V_{REF_BYP} (Pin 11): Internal Reference Power. This is an internal supply pin, do not load this pin with external circuitry. Decouple with a 0.1 μ F capacitor to GND.

V_{REFOUT} (Pin 13): Reference Output Voltage. Short to V_{REFP}. A minimum 1 μ F capacitor to ground is required. Do not load this pin with external circuitry.

V_{REFP} (Pin 14): Positive Reference Input. Tie to V_{REFOUT}.

CH1 to CH20 (Pin 16 to Pin 35): Analog Inputs. May be programmed for single-ended, differential, or ratiometric operation. The voltage on these pins can have any value between GND – 50mV and V_{DD} – 0.3V. Unused pins can be grounded or left floating.

COM (Pin 36): Analog Input. The common negative input for all single-ended configurations. The voltage on this pin can have any value between GND – 50mV and V_{DD} – 0.3V. This pin is typically tied to ground for temperature measurements.

INTERRUPT (Pin 37): This pin outputs a LOW when the device is busy either during start-up or while a conversion

cycle is in progress. This pin goes HIGH at the conclusion of the start-up state or conversion cycle.

SCK (Pin 38): Serial Clock Pin. Data is shifted out of the device on the falling edge of SCK and latched by the device on the rising edge.

SDO (Pin 39): Serial Data Out. During the data output state, this pin is used as the serial data output. When the chip select pin is HIGH, the SDO pin is in a high impedance state.

SDI (Pin 40): Serial Data Input. Used to program the device. Data is latched on the rising edge of SCK.

$\overline{\text{CS}}$ (Pin 41): Active Low Chip Select. A low on this pin enables the digital input/output. A HIGH on this pin places SDO in a high impedance state. A falling edge on $\overline{\text{CS}}$ marks the beginning of a SPI transaction and a rising edge marks the end.

RESET (Pin 42): Active Low Reset. While this pin is LOW, the device is forced into the reset state. Once this pin is returned HIGH, the device initiates its start-up sequence.

LDO (Pin 43): 2.5V LDO Output. Bypass with a 10 μ F capacitor to GND. This is an internal supply pin, do not load this pin with external circuitry.

Q3, Q2, Q1 (Pins 46, 47, 48): External Bypass Pins for –200mV integrated Charge Pump. Tie a 10 μ F X7R capacitor between Q1 and Q2 close to each pin. Tie a 10 μ F X5R capacitor from Q3 to Ground. These are internal supply pins, do not make additional connections.

BLOCK DIAGRAM

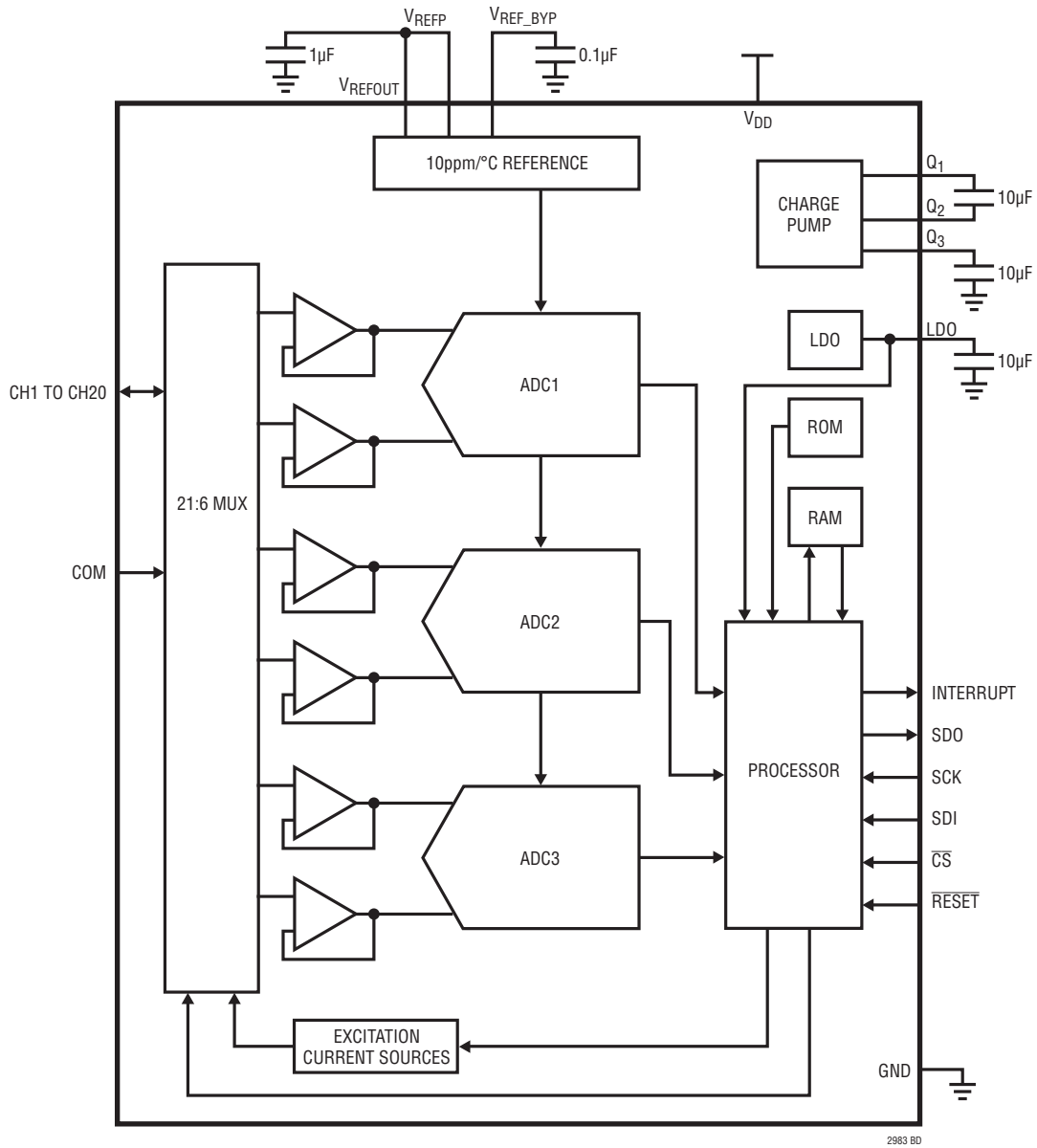

TEST CIRCUITS

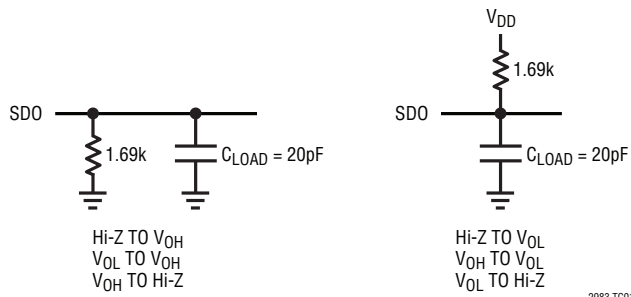

TIMING DIAGRAM

SPI Timing Diagram

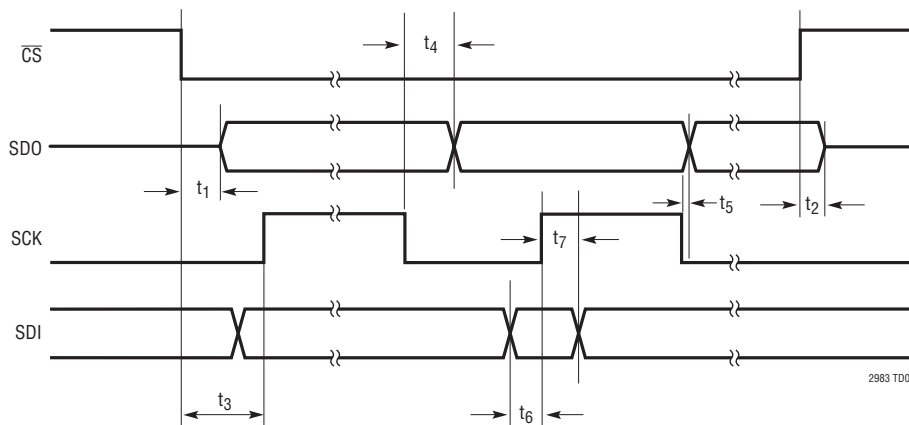

OVERVIEW

The LTC2983 measures temperature using the most common sensors (thermocouples, RTDs, thermistors, and diodes). It includes all necessary active circuitry, switches, measurement algorithms, and mathematical conversions to determine the temperature for each sensor type.

Thermocouples can measure temperatures from as low as -265°C to over 1800°C . Thermocouples generate a voltage as a function of the temperature difference between the tip (thermocouple temperature) and the electrical connection on the circuit board (cold junction temperature). In order to determine the thermocouple temperature, an accurate measurement of the cold junction temperature is required; this is known as cold junction compensation. The cold junction temperature is usually determined by placing a separate (non-thermocouple) temperature sensor at the cold junction. The LTC2983 allows diodes, RTDs, and thermistors to be used as cold junction sensors. In order to convert the voltage output from the thermocouple into a temperature result, a high order polynomial equation (up to 14th order) must be solved. The LTC2983 has these polynomials built in for virtually all standard thermocouples (J, K, N, E, R, S, T, and B). Additionally, inverse polynomials must be solved for the cold junction temperature. The LTC2983 simultaneously measures the thermocouple output and the cold junction temperature and performs all required calculations to report the thermocouple temperature in $^{\circ}\text{C}$ or $^{\circ}\text{F}$. It directly digitizes both positive and negative voltages (down to 50mV below ground) from a single ground referenced supply, includes sensor burn-out detection, and allows external protection/anti-aliasing circuits without the need of buffer circuits.

Diodes are convenient low cost sensor elements and are often used to measure cold junction temperatures in thermocouple applications. Diodes are typically used to measure temperatures from -60°C to 130°C , which is

suitable for most cold junction applications. Diodes generate an output voltage that is a function of temperature and excitation current. When the difference of two diode output voltages are taken at two different excitation current levels, the result (ΔV_{BE}) is proportional to temperature. The LTC2983 accurately generates excitation currents, measures the diode voltages, and calculates the temperature in $^{\circ}\text{C}$ or $^{\circ}\text{F}$.

RTDs and thermistors are resistors that change value as a function of temperature. RTDs can measure temperatures over a wide temperature range, from as low as -200°C to 850°C while thermistors typically operate from -40°C to 150°C . In order to measure one of these devices a precision sense resistor is tied in series with the sensor. An excitation current is applied to the network and a ratiometric measurement is made. The value, in Ω , of the RTD/thermistor can be determined from this ratio. This resistance is used to determine the temperature of the sensor element using a table lookup (RTDs) or solving Steinhart-Hart equations (thermistors). The LTC2983 automatically generates the excitation current, simultaneously measures the sense resistor and thermistor/RTD voltage, calculates the sensor resistance and reports the result in $^{\circ}\text{C}$. The LTC2983 can digitize most RTD types (PT-10, PT-50, PT-100, PT-200, PT-500, PT-1000, and NI-120), has built in coefficients for many standards (American, European, Japanese, and ITS-90), and accommodates 2-wire, 3-wire, and 4-wire configurations. It also includes coefficients for calculating the temperature of standard 2.252k, 3k, 5k, 10k, and 30k thermistors. It can be configured to share one sense resistor among multiple RTDs/thermistors and to rotate excitation current sources to remove parasitic thermal effects.

OVERVIEW

Table 1. LTC2983 Error Contribution and Peak Noise Errors

| SENSOR TYPE | TEMPERATURE RANGE | ERROR CONTRIBUTION | PEAK-TO-PEAK NOISE |
|--|--------------------------------|--|--------------------------|
| Type K Thermocouple | –200°C to 0°C 0°C to 1372°C | $\pm(\text{Temperature} \cdot 0.23\% + 0.05)^\circ\text{C}$ $\pm(\text{Temperature} \cdot 0.12\% + 0.05)^\circ\text{C}$ | $\pm 0.08^\circ\text{C}$ |
| Type J Thermocouple | –210°C to 0°C 0°C to 1200°C | $\pm(\text{Temperature} \cdot 0.23\% + 0.05)^\circ\text{C}$ $\pm(\text{Temperature} \cdot 0.10\% + 0.05)^\circ\text{C}$ | $\pm 0.07^\circ\text{C}$ |
| Type E Thermocouple | –200°C to 0°C 0°C to 1000°C | $\pm(\text{Temperature} \cdot 0.18\% + 0.05)^\circ\text{C}$ $\pm(\text{Temperature} \cdot 0.10\% + 0.05)^\circ\text{C}$ | $\pm 0.06^\circ\text{C}$ |
| Type N Thermocouple | –200°C to 0°C 0°C to 1300°C | $\pm(\text{Temperature} \cdot 0.27\% + 0.08)^\circ\text{C}$ $\pm(\text{Temperature} \cdot 0.10\% + 0.08)^\circ\text{C}$ | $\pm 0.13^\circ\text{C}$ |
| Type R Thermocouple | 0°C to 1768°C | $\pm(\text{Temperature} \cdot 0.10\% + 0.4)^\circ\text{C}$ | $\pm 0.62^\circ\text{C}$ |
| Type S Thermocouple | 0°C to 1768°C | $\pm(\text{Temperature} \cdot 0.10\% + 0.4)^\circ\text{C}$ | $\pm 0.62^\circ\text{C}$ |
| Type B Thermocouple | 400°C to 1820°C | $\pm(\text{Temperature} \cdot 0.10\%)^\circ\text{C}$ | $\pm 0.83^\circ\text{C}$ |
| Type T Thermocouple | –250°C to 0°C 0°C to 400°C | $\pm(\text{Temperature} \cdot 0.15\% + 0.05)^\circ\text{C}$ $\pm(\text{Temperature} \cdot 0.10\% + 0.05)^\circ\text{C}$ | $\pm 0.09^\circ\text{C}$ |
| External Diode (2 Reading) | –40°C to 85°C | $\pm 0.25^\circ\text{C}$ | $\pm 0.05^\circ\text{C}$ |
| External Diode (3 Reading) | –40°C to 85°C | $\pm 0.25^\circ\text{C}$ | $\pm 0.2^\circ\text{C}$ |
| Platinum RTD - PT-10, $R_{\text{SENSE}} = 1\text{k}\Omega$ | –200°C to 800°C | $\pm 0.1^\circ\text{C}$ | $\pm 0.05^\circ\text{C}$ |
| Platinum RTD - PT-100, $R_{\text{SENSE}} = 2\text{k}\Omega$ | –200°C to 800°C | $\pm 0.1^\circ\text{C}$ | $\pm 0.05^\circ\text{C}$ |
| Platinum RTD - PT-500, $R_{\text{SENSE}} = 2\text{k}\Omega$ | –200°C to 800°C | $\pm 0.1^\circ\text{C}$ | $\pm 0.02^\circ\text{C}$ |
| Platinum RTD - PT-1000, $R_{\text{SENSE}} = 2\text{k}\Omega$ | –200°C to 800°C | $\pm 0.1^\circ\text{C}$ | $\pm 0.01^\circ\text{C}$ |
| Thermistor, $R_{\text{SENSE}} = 10\text{k}\Omega$ | –40°C to 85°C | $\pm 0.1^\circ\text{C}$ | $\pm 0.01^\circ\text{C}$ |

Table 1 shows the estimated system accuracy and noise associated with specific temperature sensing devices. System accuracy and peak-to-peak noise include the effects of the ADC, internal amplifiers, excitation current sources, and integrated reference for I-grade parts. Accuracy and noise are the worst-case errors calculated from the guaranteed maximum ADC and reference specifications. Peak-to-peak noise values are calculated at 0°C (except type B was calculated at 400°C) and diode measurements use AVG = ON mode.

Thermocouple errors do not include the errors associated with the cold junction measurement. Errors associated with a specific cold junction sensor within the operating temperature range can be combined with the errors for a given thermocouple for total temperature measurement accuracy.

OVERVIEW

Memory Map

The LTC2983 channel assignment, configuration, conversion start, and results are all accessible via the RAM (see Table 2A). Table 2B details the valid SPI instruction bytes for accessing memory. The channel conversion results are mapped into memory locations 0x010 to 0x05F and can be read using the SPI interface as shown in Figure 1. A read is initiated by sending the read instruction byte = 0x03

followed by the address and then data. Channel assignment data resides in memory locations 0x200 to 0x24F and can be programmed via the SPI interface as shown in Figure 2. A write is initiated by sending the write instruction byte = 0x02 followed by the address and then data. Conversions are initiated by writing the conversion control byte (see Table 6) into memory location 0x000 (command status register).

Table 2A. Memory Map

| LTC2983 MEMORY MAP | | | | |
|--|---------------|-------------|--------------|---|
| SEGMENT | START ADDRESS | END ADDRESS | SIZE (BYTES) | DESCRIPTION |
| Command Status Register | 0x000 | 0x000 | 1 | See Table 6, Initiate Conversion, Sleep Command |
| Reserved | 0x001 | 0x00F | 15 | |
| Temperature Result Memory 20 Words - 80 Bytes | 0x010 | 0x05F | 80 | See Tables 8 to 10, Read Result |
| Reserved | 0x060 | 0x0EF | 144 | |
| Global Configuration Register | 0x0F0 | 0x0F0 | 1 | |
| Reserved | 0x0F1 | 0x0F3 | 3 | |
| Measure Multiple Channels Bit Mask | 0x0F4 | 0x0F7 | 4 | See Tables 65, 66, Run Multiple Conversions |
| Reserved | 0x0F8 | 0x0F8 | 1 | |
| Reserved | 0x0F9 | 0x0FE | 6 | |
| Mux Configuration Delay | 0x0FF | 0x0FF | 1 | See MUX Configuration Delay Section of Data Sheet |
| Reserved | 0x100 | 0x1FF | 256 | |
| Channel Assignment Data | 0x200 | 0x24F | 80 | See Tables 3, 4, Channel Assignment |
| Custom Sensor Table Data | 0x250 | 0x3CF | 384 | |
| Reserved | 0x3D0 | 0x3FF | 48 | |

Table 2B. SPI Instruction Byte

| INSTRUCTION | SPI INSTRUCTION BYTE | DESCRIPTION |
|-------------|----------------------|--------------|
| Read | 0b00000011 | See Figure 1 |
| Write | 0b00000010 | See Figure 2 |
| No Opp | 0bXXXXXX0X | |

OVERVIEW

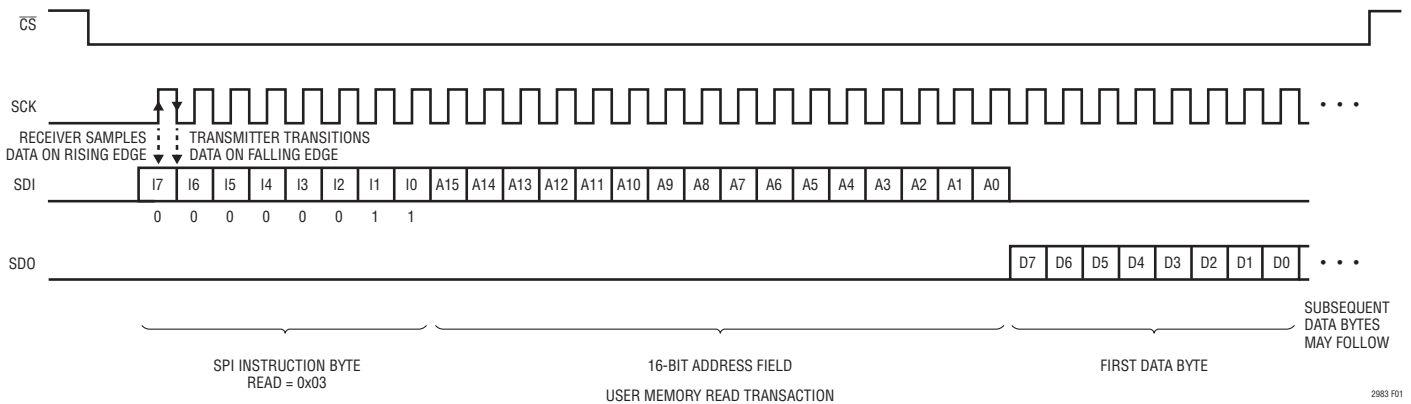

Figure 1. Memory Read Operation

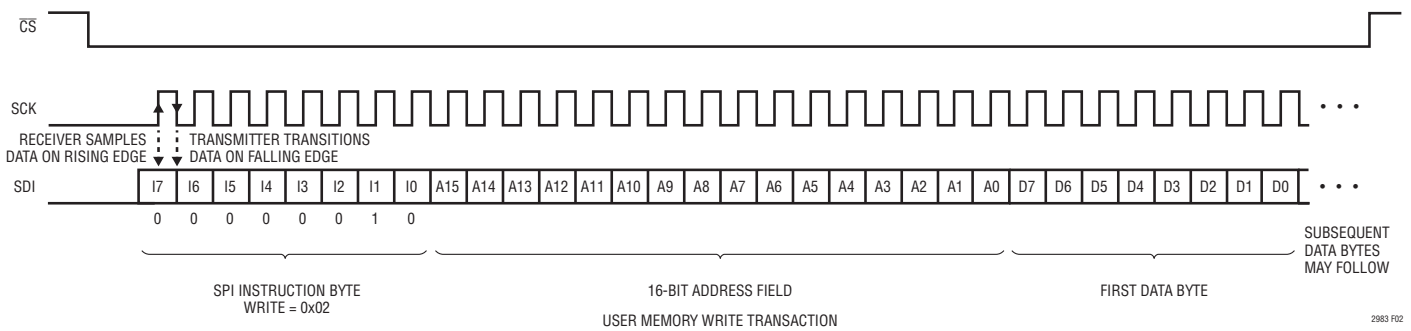

Figure 2. Memory Write Operation

APPLICATIONS INFORMATION

The LTC2983 combines high accuracy with ease of use. The basic operation is simple and is composed of five states (see Figure 3).

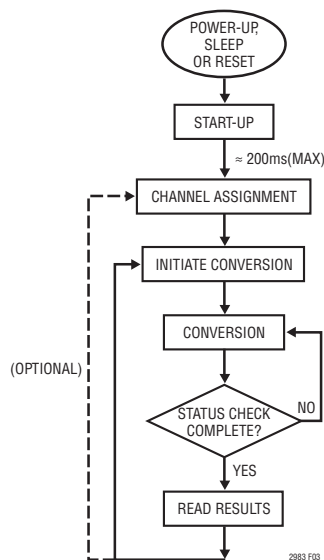

Figure 3. Basic Operation

Conversion States Overview

- 1. Start-Up.** After power is applied to the LTC2983 ($V_{DD} > 2.6V$), there is a 200ms wake up period. During this time, the LDO, charge pump, ADCs, and reference are powered up and the internal RAM is initialized. Once start-up is complete, the INTERRUPT pin goes HIGH and the command status register will return a value of 0x40 (Start bit = 0, Done bit = 1) when read.
- 2. Channel Assignment.** The device automatically enters the channel assignment state after start-up is complete. While in this state, the user writes sensor specific data for each input channel into RAM. The assignment data contains information about the sensor type, pointers to cold junction sensors or sense resistors, and sensor specific parameters.
- 3. Initiate Conversion.** A conversion is initiated by writing a measurement command into RAM memory location 0x000. This command is a pointer to the channel in which the conversion will be performed.
- 4. Conversion.** A new conversion begins automatically following an Initiate Conversion command. In this state, the ADC is running a conversion on the specified channel and associated cold junction or R_{SENSE} channel (if

applicable). The user is locked out of RAM access while in the state (except for reading status location 0x000). The end of conversion is indicated by both the INTERRUPT pin going HIGH and a status register START bit going LOW and DONE bit going HIGH.

- 5. Read Results.** In this state, the user has access to RAM and can read the completed conversion results and fault status bits. It is also possible for the user to modify/append the channel assignment data during the read results state.

Conversion State Details

State 1: Start-Up

The start-up state automatically occurs when power is applied to the LTC2983. If the power drops below a threshold of $\approx 2.6V$ and then returns to the normal operating voltage (2.85V to 5.25V), the LTC2983 resets and enters the power-up state. Note that the LTC2983 also enters the start-up state at the conclusion of the sleep state. The start-up state can also be entered at any time during normal operation by pulsing the RESET pin low.

In the first phase of the start-up state all critical analog circuits are powered up. This includes the LDO, reference, charge pump and ADCs. During this first phase, the command status register will be inaccessible to the user. This phase takes a maximum of 100mS to complete. Once this phase completes, the command status register will be accessible and return a value of 0x80 until the LTC2983 is completely initialized. Once the LTC2983 is initialized and ready to use, the interrupt pin will go high and the command status register will return a read value of 0x40 (Start bit = 0, Done bit = 1). At this point the LTC2983 is fully initialized and is ready to perform a conversion.

State 2: Channel Assignment

The LTC2983 RAM can be programmed with up to 20 sets of 32-bit (4-byte) channel assignment data. These reside sequentially in RAM with a one-to-one correspondence to each of the 20 analog input channels (see Table 3). Channels that are not used should have their channel assignment data set to all zeros (default at START-UP).

The channel assignment data contains all the necessary information associated with the specific sensor tied to that channel (see Table 4). The first five bits determine the sensor type (see Table 5). Associated with each sensor are sensor

2983fa

APPLICATIONS INFORMATION

Table 3. Channel Assignment Memory Map

| CHANNEL ASSIGNMENT NUMBER | CONFIGURATION DATA START ADDRESS | CONFIGURATION DATA ADDRESS + 1 | CONFIGURATION DATA ADDRESS + 2 | CONFIGURATION DATA END ADDRESS + 3 | SIZE (BYTES) |
|---------------------------|----------------------------------|--------------------------------|--------------------------------|------------------------------------|--------------|
| CH1 | 0x200 | 0x201 | 0x202 | 0x203 | 4 |
| CH2 | 0x204 | 0x205 | 0x206 | 0x207 | 4 |
| CH3 | 0x208 | 0x209 | 0x20A | 0x20B | 4 |
| CH4 | 0x20C | 0x20D | 0x20E | 0x20F | 4 |
| CH5 | 0x210 | 0x211 | 0x212 | 0x213 | 4 |
| CH6 | 0x214 | 0x215 | 0x216 | 0x217 | 4 |
| CH7 | 0x218 | 0x219 | 0x21A | 0x21B | 4 |
| CH8 | 0x21C | 0x21D | 0x21E | 0x21F | 4 |
| CH9 | 0x220 | 0x221 | 0x222 | 0x223 | 4 |
| CH10 | 0x224 | 0x225 | 0x226 | 0x227 | 4 |
| CH11 | 0x228 | 0x229 | 0x22A | 0x22B | 4 |
| CH12 | 0x22C | 0x22D | 0x22E | 0x22F | 4 |
| CH13 | 0x230 | 0x231 | 0x232 | 0x233 | 4 |
| CH14 | 0x234 | 0x235 | 0x236 | 0x237 | 4 |
| CH15 | 0x238 | 0x239 | 0x23A | 0x23B | 4 |
| CH16 | 0x23C | 0x23D | 0x23E | 0x23F | 4 |
| CH17 | 0x240 | 0x241 | 0x242 | 0x243 | 4 |
| CH18 | 0x244 | 0x245 | 0x246 | 0x247 | 4 |
| CH19 | 0x248 | 0x249 | 0x24A | 0x24B | 4 |
| CH20 | 0x24C | 0x24D | 0x24E | 0x24F | 4 |

Table 4. Channel Assignment Data

| Channel Assignment Memory Location | SENSOR TYPE | | SENSOR SPECIFIC CONFIGURATION | | | | | | | | | | | | | | | | | | | | | | | | | | | | | | | | | | | | | |
|------------------------------------|----------------------------------|----|-------------------------------|----|----|--|----|----|----|-------------------|-----------------|------------------|---|--------------------------------------|----|----|----------------|----|----------------------|----------------------|--------------------------------------|----|----------------------|-------------------------|-------------------------|---|---|-------------------------|---|---|---|---|--|--|--|--|--|--|--|--|
| | Configuration Data Start Address | | | | | Configuration Data Start Address + 1 | | | | | | | | Configuration Data Start Address + 2 | | | | | | | Configuration Data Start Address + 3 | | | | | | | | | | | | | | | | | | | |
| | 31 | 30 | 29 | 28 | 27 | 26 | 25 | 24 | 23 | 22 | 21 | 20 | 19 | 18 | 17 | 16 | 15 | 14 | 13 | 12 | 11 | 10 | 9 | 8 | 7 | 6 | 5 | 4 | 3 | 2 | 1 | 0 | | | | | | | | |
| Unassigned (Default) | Type = 0 | | | | | Channel Disabled | | | | | | | | | | | | | | | | | | | | | | | | | | | | | | | | | | |
| Thermocouple | Type = 1 to 9 | | | | | Cold Junction Channel Assignment [4:0] | | | | SGL=1 DIFF=0 | OC Check | OC Current [1:0] | | 0 | 0 | 0 | 0 | 0 | 0 | Standard [1:0] | | | Custom Address [5:0] | | | | | Custom Length - 1 [5:0] | | | | | | | | | | | | |
| RTD | Type = 10 to 18 | | | | | R _{SENSE} Channel Assignment [4:0] | | | | 2, 3, 4 Wire | | Excitation Mode | | Excitation Current [3:0] | | | Standard [1:0] | | | Custom Address [5:0] | | | | | Custom Length - 1 [5:0] | | | | | | | | | | | | | | | |
| Thermistor | Type = 19 to 27 | | | | | R _{SENSE} Channel Assignment [4:0] | | | | SGL=1 DIFF=0 | Excitation Mode | | Excitation Current [3:0] | | | 0 | 0 | 0 | Custom Address [5:0] | | | | | Custom Length - 1 [5:0] | | | | | | | | | | | | | | | | |
| Diode | Type = 28 | | | | | SGL=1 DIFF=0 | | | | 2 to 3 Reading | Avg on | Current [1:0] | Ideality Factor (2, 20) Value from 0 to 4 with 1/1048576 Resolution All Zeros Use Factory Set Default in ROM | | | | | | | | | | | | | | | | | | | | | | | | | | | |
| Sense Resistor | Type = 29 | | | | | Sense Resistor Value (17, 10) Up to 131,072Ω with 1/1024Ω Resolution | | | | | | | | | | | | | | | | | | | | | | | | | | | | | | | | | | |
| Direct ADC | Type = 30 | | | | | SGL=1 DIFF=0 | | | | Not Used | | | | | | | | | | | | | | | | | | | | | | | | | | | | | | |
| Reserved | Type = 31 | | | | | Not Used | | | | | | | | | | | | | | | | | | | | | | | | | | | | | | | | | | |

APPLICATIONS INFORMATION

Table 5. Sensor Type Selection

| 31 | 30 | 29 | 28 | 27 | SENSOR TYPE |
|----|----|----|----|----|---|
| 0 | 0 | 0 | 0 | 0 | Unassigned |
| 0 | 0 | 0 | 0 | 1 | Type J Thermocouple |
| 0 | 0 | 0 | 1 | 0 | Type K Thermocouple |
| 0 | 0 | 0 | 1 | 1 | Type E Thermocouple |
| 0 | 0 | 1 | 0 | 0 | Type N Thermocouple |
| 0 | 0 | 1 | 0 | 1 | Type R Thermocouple |
| 0 | 0 | 1 | 1 | 0 | Type S Thermocouple |
| 0 | 0 | 1 | 1 | 1 | Type T Thermocouple |
| 0 | 1 | 0 | 0 | 0 | Type B Thermocouple |
| 0 | 1 | 0 | 0 | 1 | Custom Thermocouple |
| 0 | 1 | 0 | 1 | 0 | RTD PT-10 |
| 0 | 1 | 0 | 1 | 1 | RTD PT-50 |
| 0 | 1 | 1 | 0 | 0 | RTD PT-100 |
| 0 | 1 | 1 | 0 | 1 | RTD PT-200 |
| 0 | 1 | 1 | 1 | 0 | RTD PT-500 |
| 0 | 1 | 1 | 1 | 1 | RTD PT-1000 |
| 1 | 0 | 0 | 0 | 0 | RTD 1000 (0.00375) |
| 1 | 0 | 0 | 0 | 1 | RTD NI-120 |
| 1 | 0 | 0 | 1 | 0 | RTD Custom |
| 1 | 0 | 0 | 1 | 1 | Thermistor 44004/44033 2.252k Ω at 25 $^{\circ}$ C |
| 1 | 0 | 1 | 0 | 0 | Thermistor 44005/44030 3k Ω at 25 $^{\circ}$ C |
| 1 | 0 | 1 | 0 | 1 | Thermistor 44007/44034 5k Ω at 25 $^{\circ}$ C |
| 1 | 0 | 1 | 1 | 0 | Thermistor 44006/44031 10k Ω at 25 $^{\circ}$ C |
| 1 | 0 | 1 | 1 | 1 | Thermistor 44008/44032 30k Ω at 25 $^{\circ}$ C |
| 1 | 1 | 0 | 0 | 0 | Thermistor YSI 400 2.252k Ω at 25 $^{\circ}$ C |
| 1 | 1 | 0 | 0 | 1 | Thermistor Spectrum 1003k 1k Ω |
| 1 | 1 | 0 | 1 | 0 | Thermistor Custom Steinhart-Hart |
| 1 | 1 | 0 | 1 | 1 | Thermistor Custom Table |
| 1 | 1 | 1 | 0 | 0 | Diode |
| 1 | 1 | 1 | 0 | 1 | Sense Resistor |
| 1 | 1 | 1 | 1 | 0 | Direct ADC |
| 1 | 1 | 1 | 1 | 1 | Reserved |

specific configurations. These include pointers to cold junction or sense resistor channels, pointers to memory locations of custom linearization data, sense resistor values and diode ideality factors. Also included in this data are, if applicable, the excitation current level, single-ended/differential input mode, as well as sensor specific controls. Separate detailed operation sections for thermocouples, RTDs, diodes, thermistors, and sense resistors describe the assignment data associated with each sensor type in more detail. The LTC2983 demonstration

software includes a utility for checking configuration data and generating annotated C-code for programming the channel assignment data.

State 3: Initiate Conversion

Once the channel assignment is complete, the device is ready to begin a conversion. A conversion is initiated by writing Start (B7 = 1) and Done (B6 = 0) followed by the desired input channel (B4 – B0) into RAM memory location 0x000 (see Tables 6 and 7). It is possible to initiate a measurement cycle on multiple channels by setting the channel selection bits (B4 to B0) to 00000; see the Running Conversions Consecutively on Multiple Channels section of the data sheet.

Table 6. Command Status Register

| B7 | B6 | B5 | B4 | B3 | B2 | B1 | B0 | |
|---------|--------|----|---------------------------|----|----|----|------------------|----------------|
| Start=1 | Done=0 | 0 | Channel Selection 1 to 20 | | | | Start Conversion | |
| 1 | 0 | 0 | 1 | 0 | 1 | 1 | 1 | Initiate Sleep |

Table 7. Input Channel Mapping

| B7 | B6 | B5 | B4 | B3 | B2 | B1 | B0 | CHANNEL SELECTED |
|------------------------|----|----|----|----|----|----|----|-------------------|
| 1 | 0 | 0 | 0 | 0 | 0 | 0 | 0 | Multiple Channels |
| 1 | 0 | 0 | 0 | 0 | 0 | 0 | 1 | CH1 |
| 1 | 0 | 0 | 0 | 0 | 0 | 1 | 0 | CH2 |
| 1 | 0 | 0 | 0 | 0 | 0 | 1 | 1 | CH3 |
| 1 | 0 | 0 | 0 | 0 | 1 | 0 | 0 | CH4 |
| 1 | 0 | 0 | 0 | 0 | 1 | 0 | 1 | CH5 |
| 1 | 0 | 0 | 0 | 0 | 1 | 1 | 0 | CH6 |
| 1 | 0 | 0 | 0 | 0 | 1 | 1 | 1 | CH7 |
| 1 | 0 | 0 | 0 | 1 | 0 | 0 | 0 | CH8 |
| 1 | 0 | 0 | 0 | 1 | 0 | 0 | 1 | CH9 |
| 1 | 0 | 0 | 0 | 1 | 0 | 1 | 0 | CH10 |
| 1 | 0 | 0 | 0 | 1 | 0 | 1 | 1 | CH11 |
| 1 | 0 | 0 | 0 | 1 | 1 | 0 | 0 | CH12 |
| 1 | 0 | 0 | 0 | 1 | 1 | 0 | 1 | CH13 |
| 1 | 0 | 0 | 0 | 1 | 1 | 1 | 0 | CH14 |
| 1 | 0 | 0 | 0 | 1 | 1 | 1 | 1 | CH15 |
| 1 | 0 | 0 | 1 | 0 | 0 | 0 | 0 | CH16 |
| 1 | 0 | 0 | 1 | 0 | 0 | 0 | 1 | CH17 |
| 1 | 0 | 0 | 1 | 0 | 0 | 1 | 0 | CH18 |
| 1 | 0 | 0 | 1 | 0 | 0 | 1 | 1 | CH19 |
| 1 | 0 | 0 | 1 | 0 | 1 | 0 | 0 | CH20 |
| 1 | 0 | 0 | 1 | 0 | 1 | 1 | 1 | Sleep |
| All Other Combinations | | | | | | | | Reserved |

APPLICATIONS INFORMATION

Bits B4 to B0 determine which input channel the conversion is performed upon and are simply the binary equivalent of the channel number (see Table 7).

Bit B5 should be set to 0.

Bits B7 and B6 serve as start/done bits. In order to start a conversion, these bits must be set to “10” (B7=1 and B6=0). When the conversion begins, the INTERRUPT pin goes LOW. Once the conversion is complete, bits B7 and B6 will toggle to “01” (B7=0 and B6=1) (Address = 0x000) and the INTERRUPT pin will go HIGH, indicating the conversion is complete and the result is available.

State 4: Conversion

The measurement cycle starts after the initiate conversion command is written into RAM location 0x000 (Table 6). The LTC2983 simultaneously measures the selected input sensor, sense resistors (RTDs and thermistors), and cold junction temperatures if applicable (thermocouples).

Once the conversion is started, the user is locked out of the RAM, with the exception of reading status data stored in RAM memory location 0x000.

Once the conversion is started the INTERRUPT pin goes low. Depending on the sensor configuration, two or three 82ms cycles are required per temperature result. These correspond to conversion rates of 167ms and 251ms, respectively. Details describing these modes are described in the 2- and 3-cycle Conversion Modes section of the data sheet.

The end of conversion can be monitored either through the interrupt pin (LOW to HIGH transition), or by reading the command status register in RAM memory location 0x000 (start bit, B7, toggles from 1 to 0 and DONE bit, B6, toggles from 0 to 1).

State 5: Read Results

Once the conversion is complete, the conversion results can be read from RAM memory locations corresponding to the input channel (see Table 8).

The conversion result is 32 bits long and contains both the sensor temperature (D23 to D0) and sensor fault data (D31 to D24) (see Tables 9A and 9B).

Table 8. Conversion Result Memory Map

| CONVERSION CHANNEL | START ADDRESS | END ADDRESS | SIZE (BYTES) |
|--------------------|---------------|-------------|--------------|
| CH1 | 0x010 | 0x013 | 4 |
| CH2 | 0x014 | 0x017 | 4 |
| CH3 | 0x018 | 0x01B | 4 |
| CH4 | 0x01C | 0x01F | 4 |
| CH5 | 0x020 | 0x023 | 4 |
| CH6 | 0x024 | 0x027 | 4 |
| CH7 | 0x028 | 0x02B | 4 |
| CH8 | 0x02C | 0x02F | 4 |
| CH9 | 0x030 | 0x033 | 4 |
| CH10 | 0x034 | 0x037 | 4 |
| CH11 | 0x038 | 0x03B | 4 |
| CH12 | 0x03C | 0x03F | 4 |
| CH13 | 0x040 | 0x043 | 4 |
| CH14 | 0x044 | 0x047 | 4 |
| CH15 | 0x048 | 0x04B | 4 |
| CH16 | 0x04C | 0x04F | 4 |
| CH17 | 0x050 | 0x053 | 4 |
| CH18 | 0x054 | 0x057 | 4 |
| CH19 | 0x058 | 0x05B | 4 |
| CH20 | 0x05C | 0x05F | 4 |

The result is reported in °C for all temperature sensors with a range of –273.16°C to 8192°C and 1/1024°C resolution or in °F with a range of –459.67°F to 8192°F with 1/1024°F resolution. Included with the conversion result are seven sensor fault bits and a valid bit. These bits are set to a 1 if there was a problem associated with the corresponding conversion result (see Table 10). Two types of errors are reported: hard errors and soft errors. Hard errors indicate the reading is invalid and the resulting temperature reported is –999°C or °F. Soft errors indicate operation beyond the normal temperature range of the sensor or the input range of the ADC. In this case, the calculated temperature is reported but the accuracy may be compromised. Details relating to each fault type are sensor specific and are described in detail in the sensor specific sections of this data sheet. Bit D24 is the valid bit and will be set to a 1 for valid data.

Once the data read is complete, the device is ready for a new initiate conversion command. In cases where new channel configuration data is required, the user has access to the RAM in order to modify existing channel assignment data.

2983fa

APPLICATIONS INFORMATION

Table 9A. Example Data Output Words (°C)

| | START ADDRESS | | | | | | | | START ADDRESS + 1 | | | | | | | | START ADDRESS + 2 | | | | | | | | START ADDRESS + 3 (END ADDRESS) | | | | | | | | | | | | | | |
|-------------|-------------------|----------------|---------------|---------------|-------------------------|--------------------------|------------------------|------------|-------------------|-----|-----|-----|-----|-----|-----|-----|-------------------|-----|-----|-----|-----|-----|----|----|---------------------------------|----|----|----|----|----|----|----|-----|--|--|--|--|--|--|
| | D31 | D30 | D29 | D28 | D27 | D26 | D25 | D24 | D23 | D22 | D21 | D20 | D19 | D18 | D17 | D16 | D15 | D14 | D13 | D12 | D11 | D10 | D9 | D8 | D7 | D6 | D5 | D4 | D3 | D2 | D1 | D0 | | | | | | | |
| | Fault Data | | | | | | | | SIGN MSB | | | | | | | | | | | | | | | | | | | | | | | | LSB | | | | | | |
| Temperature | Sensor Hard Fault | ADC Hard Fault | CJ Hard Fault | CJ Soft Fault | Sensor Over Range Fault | Sensor Under Range Fault | ADC Out of Range Fault | Valid If 1 | 4096°C | | | | | | | | 1°C | | | | | | | | 1/1024°C | | | | | | | | | | | | | | |
| 8191.999°C | | | | | | | | 1 | 0 | 1 | 1 | 1 | 1 | 1 | 1 | 1 | 1 | 1 | 1 | 1 | 1 | 1 | 1 | 1 | 1 | 1 | 1 | 1 | 1 | 1 | 1 | | | | | | | | |
| 1024°C | | | | | | | | 1 | 0 | 0 | 0 | 0 | 1 | 0 | 0 | 0 | 0 | 0 | 0 | 0 | 0 | 0 | 0 | 0 | 0 | 0 | 0 | 0 | 0 | 0 | 0 | 0 | | | | | | | |
| 1°C | | | | | | | | 1 | 0 | 0 | 0 | 0 | 0 | 0 | 0 | 0 | 0 | 0 | 0 | 0 | 0 | 0 | 1 | 0 | 0 | 0 | 0 | 0 | 0 | 0 | 0 | 0 | | | | | | | |
| 1/1024°C | | | | | | | | 1 | 0 | 0 | 0 | 0 | 0 | 0 | 0 | 0 | 0 | 0 | 0 | 0 | 0 | 0 | 0 | 0 | 0 | 0 | 0 | 0 | 0 | 0 | 0 | 1 | | | | | | | |
| 0°C | | | | | | | | 1 | 0 | 0 | 0 | 0 | 0 | 0 | 0 | 0 | 0 | 0 | 0 | 0 | 0 | 0 | 0 | 0 | 0 | 0 | 0 | 0 | 0 | 0 | 0 | 0 | | | | | | | |
| -1/1024°C | | | | | | | | 1 | 1 | 1 | 1 | 1 | 1 | 1 | 1 | 1 | 1 | 1 | 1 | 1 | 1 | 1 | 1 | 1 | 1 | 1 | 1 | 1 | 1 | 1 | 1 | | | | | | | | |
| -1°C | | | | | | | | 1 | 1 | 1 | 1 | 1 | 1 | 1 | 1 | 1 | 1 | 1 | 1 | 1 | 1 | 1 | 0 | 0 | 0 | 0 | 0 | 0 | 0 | 0 | 0 | | | | | | | | |
| -273.15°C | | | | | | | | 1 | 1 | 1 | 1 | 1 | 1 | 0 | 1 | 1 | 1 | 0 | 1 | 1 | 1 | 0 | 1 | 1 | 0 | 1 | 1 | 0 | 0 | 1 | 1 | | | | | | | | |

Table 9B. Example Data Output Words (°F)

| | START ADDRESS | | | | | | | | START ADDRESS + 1 | | | | | | | | START ADDRESS + 2 | | | | | | | | START ADDRESS + 3 (END ADDRESS) | | | | | | | | | | | | | | |
|-------------|-------------------|----------------|---------------|---------------|-------------------------|--------------------------|------------------------|------------|-------------------|-----|-----|-----|-----|-----|-----|-----|-------------------|-----|-----|-----|-----|-----|----|----|---------------------------------|----|----|----|----|----|----|----|-----|--|--|--|--|--|--|
| | D31 | D30 | D29 | D28 | D27 | D26 | D25 | D24 | D23 | D22 | D21 | D20 | D19 | D18 | D17 | D16 | D15 | D14 | D13 | D12 | D11 | D10 | D9 | D8 | D7 | D6 | D5 | D4 | D3 | D2 | D1 | D0 | | | | | | | |
| | Fault Data | | | | | | | | SIGN MSB | | | | | | | | | | | | | | | | | | | | | | | | LSB | | | | | | |
| Temperature | Sensor Hard Fault | ADC Hard Fault | CJ Hard Fault | CJ Soft Fault | Sensor Over Range Fault | Sensor Under Range Fault | ADC Out of Range Fault | Valid If 1 | 4096°F | | | | | | | | 1°F | | | | | | | | 1/1024°F | | | | | | | | | | | | | | |
| 8191.999°F | | | | | | | | 1 | 0 | 1 | 1 | 1 | 1 | 1 | 1 | 1 | 1 | 1 | 1 | 1 | 1 | 1 | 1 | 1 | 1 | 1 | 1 | 1 | 1 | 1 | | | | | | | | | |
| 1024°F | | | | | | | | 1 | 0 | 0 | 0 | 0 | 1 | 0 | 0 | 0 | 0 | 0 | 0 | 0 | 0 | 0 | 0 | 0 | 0 | 0 | 0 | 0 | 0 | 0 | 0 | | | | | | | | |
| 1°F | | | | | | | | 1 | 0 | 0 | 0 | 0 | 0 | 0 | 0 | 0 | 0 | 0 | 0 | 0 | 0 | 0 | 1 | 0 | 0 | 0 | 0 | 0 | 0 | 0 | 0 | | | | | | | | |
| 1/1024°F | | | | | | | | 1 | 0 | 0 | 0 | 0 | 0 | 0 | 0 | 0 | 0 | 0 | 0 | 0 | 0 | 0 | 0 | 0 | 0 | 0 | 0 | 0 | 0 | 0 | 1 | | | | | | | | |
| 0°F | | | | | | | | 1 | 0 | 0 | 0 | 0 | 0 | 0 | 0 | 0 | 0 | 0 | 0 | 0 | 0 | 0 | 0 | 0 | 0 | 0 | 0 | 0 | 0 | 0 | 0 | | | | | | | | |
| -1/1024°F | | | | | | | | 1 | 1 | 1 | 1 | 1 | 1 | 1 | 1 | 1 | 1 | 1 | 1 | 1 | 1 | 1 | 1 | 1 | 1 | 1 | 1 | 1 | 1 | 1 | | | | | | | | | |
| -1°F | | | | | | | | 1 | 1 | 1 | 1 | 1 | 1 | 1 | 1 | 1 | 1 | 1 | 1 | 1 | 1 | 1 | 0 | 0 | 0 | 0 | 0 | 0 | 0 | 0 | 0 | | | | | | | | |
| -459.67°F | | | | | | | | 1 | 1 | 1 | 1 | 1 | 1 | 0 | 0 | 0 | 1 | 1 | 0 | 1 | 0 | 0 | 0 | 1 | 0 | 1 | 0 | 0 | 1 | 0 | | | | | | | | | |

Table 10. Sensor Fault Reporting

| BIT | FAULT | ERROR TYPE | DESCRIPTION | OUTPUT RESULT |
|-----|-----------------------|------------|--|-----------------|
| D31 | Sensor Hard Fault | Hard | Bad Sensor Reading | -999°C or °F |
| D30 | Hard ADC-Out-of-Range | Hard | Bad ADC Reading (Could Be Large External Noise Event) | -999°C or °F |
| D29 | CJ Hard Fault | Hard | Cold Junction Sensor Has a Hard Fault Error | -999°C or °F |
| D28 | CJ Soft Fault | Soft | Cold Junction Sensor Result Is Beyond Normal Range | Suspect Reading |
| D27 | Sensor Over Range | Soft | Sensor Reading Is Above Normal Range | Suspect Reading |
| D26 | Sensor Under Range | Soft | Sensor Reading Is Below Normal Range | Suspect Reading |
| D25 | ADC Out-of-Range | Soft | ADC Absolute Input Voltage Is Beyond $\pm 1.125 \cdot V_{REF}/2$ | Suspect Reading |
| D24 | Valid | NA | Result Valid (Should Be 1) Discard Results if 0 | Suspect Reading |

2983fa

APPLICATIONS INFORMATION

THERMOCOUPLE MEASUREMENTS

Table 11. Thermocouple Channel Assignment Word

| | (1) THERMOCOUPLE TYPE | | | | | (2) COLD JUNCTION CHANNEL POINTER | | | | | (3) SENSOR CONFIGURATION | | | | (4) CUSTOM THERMOCOUPLE DATA POINTER | | | | | | | | | | | | | | | | | |
|------------------|-----------------------|----|----|----|----|--|----|----|----|----|--------------------------|----------|------------------|----|--------------------------------------|----|----|----|----|----|----------------------|----|---|---|---|---|------------------------|---|---|---|---|---|
| | TABLES 4, 12 | | | | | TABLE 13 | | | | | TABLE 14 | | | | TABLES 67 TO 69 | | | | | | | | | | | | | | | | | |
| Measurement Type | 31 | 30 | 29 | 28 | 27 | 26 | 25 | 24 | 23 | 22 | 21 | 20 | 19 | 18 | 17 | 16 | 15 | 14 | 13 | 12 | 11 | 10 | 9 | 8 | 7 | 6 | 5 | 4 | 3 | 2 | 1 | 0 |
| Thermocouple | Types 1 to 9 | | | | | Cold Junction Channel Assignment [4:0] | | | | | SGL=1 DIFF=0 | OC Check | OC Current [1:0] | | 0 | 0 | 0 | 0 | 0 | 0 | Custom Address [5:0] | | | | | | Custom Length –1 [5:0] | | | | | |

Channel Assignment – Thermocouples

For each thermocouple tied to the LTC2983, a 32-bit channel assignment word is programmed into a memory location corresponding to the channel the sensor is tied to (see Table 11). This word includes (1) thermocouple type, (2) cold junction channel pointer, (3) sensor configuration, and (4) custom thermocouple data pointer.

(1) Thermocouple Type

The thermocouple type is determined by the first five input bits B31 to B27 as shown in Table 12. Standard NIST coefficients for types J,K,E,N,R,S,T and B thermocouples are stored in the device ROM. If custom thermocouples are used, the custom thermocouple sensor type can be selected. In this case, user-specific data can be stored in the on-chip RAM starting at the address defined in the custom thermocouple data pointer.

(2) Cold Junction Channel Pointer

The cold junction compensation can be a diode, RTD, or thermistor. The cold junction channel pointer tells the LTC2983 which channel (1 to 20) the cold junction

sensor is assigned to (see Table 13). When a conversion is performed on a channel tied to a thermocouple, the cold junction sensor is simultaneously and automatically measured. The final output data uses the embedded coefficients stored in ROM to automatically compensate the cold junction temperature and output the thermocouple sensor temperature.

Table 13. Cold Junction Channel Pointer

| (2) COLD JUNCTION CHANNEL POINTER | | | | | COLD JUNCTION CHANNEL |
|-----------------------------------|-----|-----|-----|-----|--|
| B26 | B25 | B24 | B23 | B22 | |
| 0 | 0 | 0 | 0 | 0 | No Cold Junction Compensation, 0°C Used for Calculations |
| 0 | 0 | 0 | 0 | 1 | CH1 |
| 0 | 0 | 0 | 1 | 0 | CH2 |
| 0 | 0 | 0 | 1 | 1 | CH3 |
| 0 | 0 | 1 | 0 | 0 | CH4 |
| 0 | 0 | 1 | 0 | 1 | CH5 |
| 0 | 0 | 1 | 1 | 0 | CH6 |
| 0 | 0 | 1 | 1 | 1 | CH7 |
| 0 | 1 | 0 | 0 | 0 | CH8 |
| 0 | 1 | 0 | 0 | 1 | CH9 |
| 0 | 1 | 0 | 1 | 0 | CH10 |
| 0 | 1 | 0 | 1 | 1 | CH11 |
| 0 | 1 | 1 | 0 | 0 | CH12 |
| 0 | 1 | 1 | 0 | 1 | CH13 |
| 0 | 1 | 1 | 1 | 0 | CH14 |
| 0 | 1 | 1 | 1 | 1 | CH15 |
| 1 | 0 | 0 | 0 | 0 | CH16 |
| 1 | 0 | 0 | 0 | 1 | CH17 |
| 1 | 0 | 0 | 1 | 0 | CH18 |
| 1 | 0 | 0 | 1 | 1 | CH19 |
| 1 | 0 | 1 | 0 | 0 | CH20 |
| All Other Combinations | | | | | Invalid |

Table 12. Thermocouple Type

| (1) THERMOCOUPLE TYPE | | | | | THERMOCOUPLE TYPES |
|-----------------------|-----|-----|-----|-----|---------------------|
| B31 | B30 | B29 | B28 | B27 | |
| 0 | 0 | 0 | 0 | 1 | Type J Thermocouple |
| 0 | 0 | 0 | 1 | 0 | Type K Thermocouple |
| 0 | 0 | 0 | 1 | 1 | Type E Thermocouple |
| 0 | 0 | 1 | 0 | 0 | Type N Thermocouple |
| 0 | 0 | 1 | 0 | 1 | Type R Thermocouple |
| 0 | 0 | 1 | 1 | 0 | Type S Thermocouple |
| 0 | 0 | 1 | 1 | 1 | Type T Thermocouple |
| 0 | 1 | 0 | 0 | 0 | Type B Thermocouple |
| 0 | 1 | 0 | 0 | 1 | Custom Thermocouple |

APPLICATIONS INFORMATION

(3) Sensor Configuration

The sensor configuration field (see Table 14) is used to select single-ended (B21=1) or differential (B21=0) input and allows selection of open circuit current if internal open-circuit detect is enabled (bit B20). Single-ended readings are measured relative to the COM pin and differential are measured between the selected CH_{TC} and adjacent CH_{TC-1} (see Figure 4). If open-circuit detection is enabled, B20=1, then the user can select the pulsed current value applied during open-circuit detect using bits B18 and B19. The user determines the value of the open circuit current based on the size of the external protection resistor and filter capacitor (typically $10\mu A$). This network needs to settle within 50ms to $1\mu V$ or less. The duration of the current pulse is approximately 8ms and occurs 50ms before the normal conversion cycle.

Thermocouple channel assignments follow the general convention shown in Figure 4. The thermocouple positive terminal ties to CH_{TC} (where TC is the selected channel number) for both the single-ended and differential modes of operation. For single-ended measurements the thermocouple negative terminal and the COM pin are grounded. The thermocouple negative terminal is tied to CH_{TC-1} for differential measurements. This node can either be grounded or tied to a bias voltage.

(4) Custom Thermocouple Data Pointer

See Custom Thermocouples section near the end of this data sheet for more information.

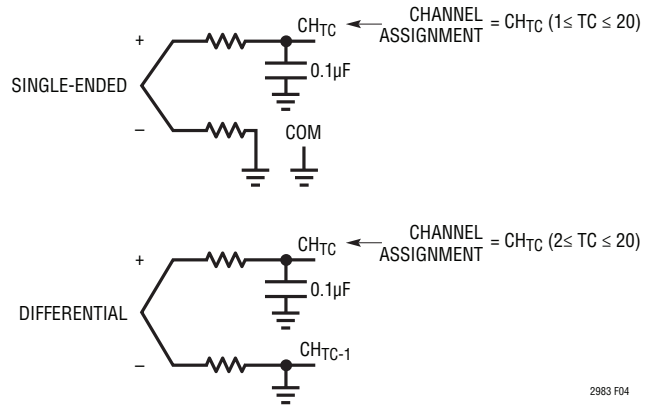

Figure 4. Thermocouple Channel Assignment Convention

Table 14. Sensor Configuration

| (3) SENSOR CONFIGURATION | | | | SINGLE-ENDED/ DIFFERENTIAL | OPEN-CIRCUIT CURRENT |
|--------------------------|-------------|------------|-----|-------------------------------|-------------------------|
| SGL | OC CHECK | OC CURRENT | | | |
| B21 | B20 | B19 | B18 | | |
| 0 | 0 | X | X | Differential | External |
| 0 | 1 | 0 | 0 | Differential | $10\mu A$ |
| 0 | 1 | 0 | 1 | Differential | $100\mu A$ |
| 0 | 1 | 1 | 0 | Differential | $500\mu A$ |
| 0 | 1 | 1 | 1 | Differential | 1mA |
| 1 | 0 | X | X | Single-Ended | External |
| 1 | 1 | 0 | 0 | Single-Ended | $10\mu A$ |
| 1 | 1 | 0 | 1 | Single-Ended | $100\mu A$ |
| 1 | 1 | 1 | 0 | Single-Ended | $500\mu A$ |
| 1 | 1 | 1 | 1 | Single-Ended | 1mA |

APPLICATIONS INFORMATION

Fault Reporting – Thermocouple

Each sensor type has a unique fault reporting mechanism indicated in the upper byte of the data output word. Table 15 shows faults reported in the measurement of thermocouples.

Bit D31 indicates the thermocouple sensor is open (broken or not plugged in), the cold junction sensor has a hard fault, or the ADC is out of range. This is indicated by a reading well beyond the normal operating range. Bit D30 indicates a bad ADC reading. This can be a result of either a broken (open) sensor or an excessive noise event (ESD or static discharge into the sensor path). Either of these are a hard error and -999°C or $^{\circ}\text{F}$ is reported. In the case of an excessive noise event, the device should recover and the following conversions will be valid if the noise event was a random, infrequent event. Bit D29 indicates a hard fault occurred at the cold junction sensor and -999°C or $^{\circ}\text{F}$ is reported. Refer to the specific sensor (diode, thermistor, or RTD) used for cold junction compensation. Bit D28 indicates a soft fault occurred at the cold junction

sensor. A valid temperature is reported, but the accuracy may be compromised since the cold junction sensor is operating outside its normal temperature range. Bits D27 and D26 indicate over or under temperature limits have been exceeded for specific thermocouple types, as defined in Table 16. Bit D25 indicates the absolute voltage measured by the ADC is beyond its normal operating range. This fault reflects a reading that is well beyond the normal range of a thermocouple.

Table 16. Thermocouple Temperature Limits

| THERMOCOUPLE TYPE | LOW TEMP LIMIT $^{\circ}\text{C}$ | HIGH TEMP LIMIT $^{\circ}\text{C}$ |
|-------------------|-----------------------------------|------------------------------------|
| J-Type | -210 | 1200 |
| K-Type | -265 | 1372 |
| E-Type | -265 | 1000 |
| N-Type | -265 | 1300 |
| R-type | -50 | 1768 |
| S-Type | -50 | 1768 |
| T-Type | -265 | 400 |
| B-Type | 40 | 1820 |
| Custom | Lowest Table Entry | Highest Table Entry |

Table 15. Thermocouple Fault Reporting

| BIT | FAULT | ERROR TYPE | DESCRIPTION | OUTPUT RESULT |
|-----|-----------------------|------------|---|--|
| D31 | Sensor Hard Fault | Hard | Open Circuit or Hard ADC or Hard CJ | -999°C or $^{\circ}\text{F}$ |
| D30 | Hard ADC-Out-of-Range | Hard | Bad ADC Reading (Could Be Large External Noise Event) | -999°C or $^{\circ}\text{F}$ |
| D29 | CJ Hard Fault | Hard | Cold Junction Sensor Has a Hard Fault Error | -999°C or $^{\circ}\text{F}$ |
| D28 | CJ Soft Fault | Soft | Cold Junction Sensor Result Is Beyond Normal Range | Suspect Reading |
| D27 | Sensor Over Range | Soft | Thermocouple Reading Greater Than High Limit | Suspect Reading |
| D26 | Sensor Under Range | Soft | Thermocouple Reading Less Than Low Limit | Suspect Reading |
| D25 | ADC Out-of-Range | Soft | ADC Absolute Input Voltage Is Beyond $\pm 1.125 \cdot V_{\text{REF}}/2$ | Suspect Reading |
| D24 | Valid | NA | Result Valid (Should Be 1) Discard Results if 0 | Valid Reading |

APPLICATIONS INFORMATION

DIODE MEASUREMENTS

Table 17. Diode Channel Assignment Word

| | (1) SENSOR TYPE | | | | | (2) SENSOR CONFIGURATION | | | (3) EXCITATION CURRENT | | (4) DIODE IDEALITY FACTOR VALUE | | | | | | | | | | | | | | | | | | | | | |
|-------------------|-----------------|----|----|----|----|--------------------------|--------------------|-----------|------------------------|----|--|----|----|----|----|----|----|----|----|----|----|----|---|---|---|---|---|---|---|---|---|---|
| | TABLE 18 | | | | | | | | TABLE 19 | | TABLE 20 | | | | | | | | | | | | | | | | | | | | | |
| Measurement Class | 31 | 30 | 29 | 28 | 27 | 26 | 25 | 24 | 23 | 22 | 21 | 20 | 19 | 18 | 17 | 16 | 15 | 14 | 13 | 12 | 11 | 10 | 9 | 8 | 7 | 6 | 5 | 4 | 3 | 2 | 1 | 0 |
| Diode | Type = 28 | | | | | SGL=1 DIFF=0 | 2 or 3 Readings | Avg on | Current [1:0] | | Non-Ideality Factor (2, 20) Value from 0 to 4 with 1/1048576 Resolution All Zeros Uses a Factory Set Default of 1.003 | | | | | | | | | | | | | | | | | | | | | |

Channel Assignment – Diode

For each diode tied to the LTC2983, a 32-bit channel assignment word is programmed into a memory location corresponding to the channel the sensor is tied to (see Table 17). This word includes (1) diode sensor selection, (2) sensor configuration, (3) excitation current, and (4) diode ideality factor.

1) Sensor Type

The diode is selected by the first five input bits B31 to B27 (see Table 18).

Table 18. Diode Sensor Selection

| (1) SENSOR TYPE | | | | | SENSOR TYPE |
|-----------------|-----|-----|-----|-----|-------------|
| B31 | B30 | B29 | B28 | B27 | |
| 1 | 1 | 1 | 0 | 0 | Diode |

(2) Sensor Configuration

The sensor configuration field (bits B26 to B24) is used to define various diode measurement properties. Configuration bit B26 is set high for single-ended (measurement relative to COM) and low for differential.

Bit B25 sets the measurement algorithm. If B25 is low, two conversion cycles (one at **1I** and one at **8I** current excitation) are used to measure the diode. This is used in applications where parasitic resistance between the LTC2983 and the diode is small. Parasitic resistance effects can be removed by setting bit B25 high, enabling three conversion cycles (one at **1I**, one at **4I** and one at **8I**).

Table 20. Programming Diode Ideality Factor

| | (4) DIODE IDEALITY FACTOR VALUE | | | | | | | | | | | | | | | | | | | | | |
|-----------------|---------------------------------|----------------|-----------------|-----------------|-----------------|-----------------|-----------------|-----------------|-----------------|-----------------|-----------------|------------------|------------------|------------------|------------------|------------------|------------------|------------------|------------------|------------------|------------------|------------------|
| | B21 | B20 | B19 | B18 | B17 | B16 | B15 | B14 | B13 | B12 | B11 | B10 | B9 | B8 | B7 | B6 | B5 | B4 | B3 | B2 | B1 | B0 |
| Example η | 2 ¹ | 2 ⁰ | 2 ⁻¹ | 2 ⁻² | 2 ⁻³ | 2 ⁻⁴ | 2 ⁻⁵ | 2 ⁻⁶ | 2 ⁻⁷ | 2 ⁻⁸ | 2 ⁻⁹ | 2 ⁻¹⁰ | 2 ⁻¹¹ | 2 ⁻¹² | 2 ⁻¹³ | 2 ⁻¹⁴ | 2 ⁻¹⁵ | 2 ⁻¹⁶ | 2 ⁻¹⁷ | 2 ⁻¹⁸ | 2 ⁻¹⁹ | 2 ⁻²⁰ |
| 1.25 | 0 | 1 | 0 | 1 | 0 | 0 | 0 | 0 | 0 | 0 | 0 | 0 | 0 | 0 | 0 | 0 | 0 | 0 | 0 | 0 | 0 | 0 |
| 1.003 (Default) | 0 | 0 | 0 | 0 | 0 | 0 | 0 | 0 | 0 | 0 | 0 | 0 | 0 | 0 | 0 | 0 | 0 | 0 | 0 | 0 | 0 | 0 |
| 1.006 | 0 | 1 | 0 | 0 | 0 | 0 | 0 | 0 | 0 | 1 | 1 | 0 | 0 | 0 | 1 | 0 | 0 | 1 | 0 | 0 | 1 | 1 |

Bit B24 enables a running average of the diode temperature reading. This reduces the noise when the diode is used as a cold junction temperature element on an isothermal block where temperatures change slowly.

The algorithm used for diode averaging is a simple recursive running average. The new value is equal to the average of the current reading plus the previous value.

$$NEW\ VALUE = \frac{CURRENT\ READING}{2} + \frac{PREVIOUS\ VALUE}{2}$$

If the current reading is 2°C above or below the previous value, the new value is reset to the current reading.

(3) Excitation Current

The next field in the channel assignment word (B23 to B22) controls the magnitude of the excitation current applied to the diode (see Table 19). In the two conversion cycle mode, the device performs the first conversion at a current equal to 8x the excitation current **1I**. The second conversion occurs at **1I**. Alternatively, in the three conversion cycle mode the first conversion excitation current is **8I**, the second is **4I** and the 3rd is **1I**.

Table 19. Diode Excitation Current Selection

| (3) EXCITATION CURRENT | | 1I | 4I | 8I |
|------------------------|-----|------|-------|-------|
| B23 | B22 | | | |
| 0 | 0 | 10µA | 40µA | 80µA |
| 0 | 1 | 20µA | 80µA | 160µA |
| 1 | 0 | 40µA | 160µA | 320µA |
| 1 | 1 | 80µA | 320µA | 640µA |

APPLICATIONS INFORMATION

(4) Diode Ideality Factor

The last field in the channel assignment word (B21 to B0) sets the diode ideality factor within the range 0 to 4 with $1/1048576$ (2^{-20}) resolution. The top two bits (B21 to B20) are the integer part and bits B19 to B0 are the fractional part of the ideality factor (see Table 20).

Diode channel assignments follow the general convention shown in Figure 5. The anode ties to CH_D (where D is the selected channel number) for both the single-ended and differential modes of operation, and the cathode is grounded. For differential diode measurements, the cathode is also tied to CH_{D-1} .

Fault Reporting - Diode

Each sensor type has unique fault reporting mechanism indicated in the upper byte of the data output word. Table 21 shows faults reported in the measurement of diodes.

Bit D31 indicates the diode is open, shorted, not plugged in, wired backwards, or the ADC reading is bad. Any of these are hard faults and -999°C or $^{\circ}\text{F}$ is reported. Bit D30 indicates a bad ADC reading. This can be a result of either a broken (open) sensor or an excessive noise event (ESD or static discharge into the sensor path). This is a

hard error and -999°C or $^{\circ}\text{F}$ is reported. In the case of an excessive noise event, the device should recover and the following conversions will be valid if the noise event was a random, infrequent event. Bits D29 and D28 are not used for diodes. Bits D27 and D26 indicate over or under temperature limits (defined as $T > 130^{\circ}\text{C}$ or $T < -60^{\circ}\text{C}$). The calculated temperature is reported, but the accuracy may be compromised. Bit D25 indicates the absolute voltage measured by the ADC is beyond its normal operating range. If a diode is used as the cold junction element, any hard or soft error is flagged in the corresponding thermocouple result (bits D28 and D29 in Table 15).

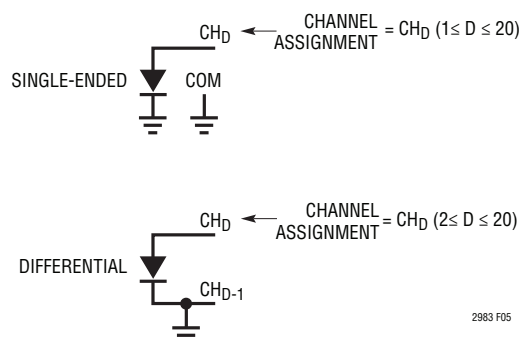

Figure 5. Diode Channel Assignment Convention

Table 21. Diode Fault Reporting

| BIT | FAULT | ERROR TYPE | DESCRIPTION | OUTPUT RESULT |
|-----|-----------------------|------------|---|--|
| D31 | Sensor Hard Fault | Hard | Open, Short, Reversed, or Hard ADC | -999°C or $^{\circ}\text{F}$ |
| D30 | Hard ADC-Out-of-Range | Hard | Bad ADC Reading (Could Be Large External Noise Event) | -999°C or $^{\circ}\text{F}$ |
| D29 | Not Used for Diodes | N/A | Always 0 | |
| D28 | Not Used for Diodes | N/A | Always 0 | |
| D27 | Sensor Over Range | Soft | $T > 130^{\circ}\text{C}$ | Suspect Reading |
| D26 | Sensor Under Range | Soft | $T < -60^{\circ}\text{C}$ | Suspect Reading |
| D25 | ADC Out-of-Range | Soft | ADC Absolute Input Voltage Is Beyond $\pm 1.125 \cdot V_{\text{REF}}/2$ | Suspect Reading |
| D24 | Valid | NA | Result Valid (Should Be 1) Discard Results if 0 | Valid Reading |

APPLICATIONS INFORMATION

Example: Single-Ended Type K and Differential Type T Thermocouples with Shared Diode Cold Junction Compensation

Figure 6 shows a typical temperature measurement system where two thermocouples share a single cold junction diode. In this example, a Type K thermocouple is tied to CH1 and a Type T thermocouple is tied to CH3 and CH4. They both share a single cold junction diode with ideality factor of $\eta=1.003$ tied to CH2. Channel assignment data for both thermocouples and the diode are

shown in Tables 22 to 24. Thermocouple #1 (Type K) sensor type and configuration data are assigned to CH1. 32-bits of binary configuration data are mapped directly into memory locations 0x200 to 0x203 (see Table 22). The cold junction diode sensor type and configuration data are assigned to CH2. 32-bits of binary configuration data are mapped directly into memory locations 0x204 to 0x207 (see Table 23). Thermocouple #2 (Type T) sensor type and configuration data are assigned to CH4. 32-bits of binary configuration data are mapped directly

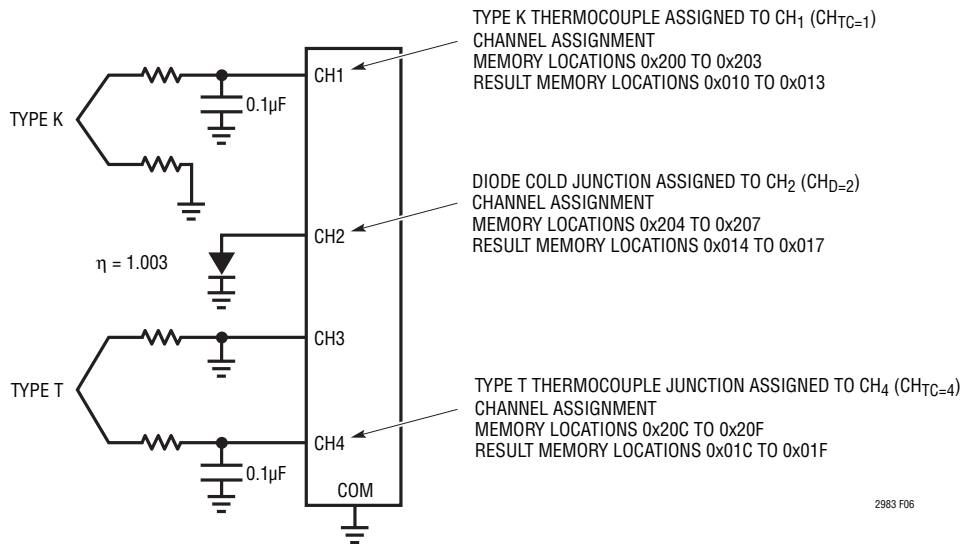

Figure 6. Dual Thermocouple with Diode Cold Junction Example

APPLICATIONS INFORMATION

into memory locations 0x20C to 0x20F (see Table 24). A conversion is initiated on CH1 by writing 10000001 into memory location 0x000. Both the Type K thermocouple and the diode are measured simultaneously. The LTC2983 calculates the cold junction compensation and determines the temperature of the Type K thermocouple. Once the

conversion is complete, the INTERRUPT pin goes HIGH and memory location 0x000 becomes 01000001. Similarly, a conversion can be initiated on CH4 by writing 10000100 into memory location 0x000. The results (in °C) can be read from memory locations 0x010 to 0x013 for CH1 and 0x01C to 0x01F for CH4.

Table 22. Thermocouple #1 Channel Assignment (Type K, Cold Junction CH₂, Single-Ended, 10μA Open-Circuit Detect)

| CONFIGURATION FIELD | DESCRIPTION | # BITS | BINARY DATA | MEMORY ADDRESS 0x200 | MEMORY ADDRESS 0x201 | MEMORY ADDRESS 0x202 | MEMORY ADDRESS 0x203 |
|--------------------------------------|---------------------------------|--------|--------------|----------------------|----------------------|----------------------|-------------------------|
| (1) Thermocouple Type | Type K | 5 | 00010 | 0 0 0 1 0 | | | |
| (2) Cold Junction Channel Pointer | CH ₂ | 5 | 00010 | | 0 0 0 1 0 | | |
| (3) Sensor Configuration | Single-Ended, 10μA Open-Circuit | 4 | 1100 | | 1 1 0 0 | | |
| Not Used | Set These Bits to 0 | 6 | 000000 | | | 0 0 0 0 0 0 | |
| (4) Custom Thermocouple Data Pointer | Not Custom | 12 | 000000000000 | | | | 0 0 0 0 0 0 0 0 0 0 0 0 |

Table 23. Diode Channel Assignment (Single-Ended 3-Reading, Averaging On, 20μA/80μA Excitation, Ideality Factor = 1.003)

| CONFIGURATION FIELD | DESCRIPTION | # BITS | BINARY DATA | MEMORY ADDRESS 0x204 | MEMORY ADDRESS 0x205 | MEMORY ADDRESS 0x206 | MEMORY ADDRESS 0x207 |
|--------------------------|-------------------------------------|--------|-----------------------|----------------------|----------------------|---|----------------------|
| (1) Sensor Type | Diode | 5 | 11100 | 1 1 1 0 0 | | | |
| (2) Sensor Configuration | Single-Ended, 3-Reading, Average On | 3 | 111 | | 1 1 1 | | |
| (3) Excitation Current | 20μA, 80μA, 160μA | 2 | 01 | | 0 1 | | |
| (4) Ideality Factor | 1.003 | 22 | 010000000110001001001 | | | 0 1 0 0 0 0 0 0 0 0 0 1 1 0 0 0 1 0 0 1 0 0 1 | |

Table 24. Thermocouple #2 Channel Assignment (Type T, Cold Junction CH₂, Differential, 100μA Open-Circuit Detect)

| CONFIGURATION FIELD | DESCRIPTION | # BITS | BINARY DATA | MEMORY ADDRESS 0x20C | MEMORY ADDRESS 0x20D | MEMORY ADDRESS 0x20E | MEMORY ADDRESS 0x20F |
|--------------------------------------|--|--------|--------------|----------------------|----------------------|----------------------|-------------------------|
| (1) Thermocouple Type | Type T | 5 | 00111 | 0 0 1 1 1 | | | |
| (2) Cold Junction Channel Pointer | CH ₂ | 5 | 00010 | | 0 0 0 1 0 | | |
| (3) Sensor Configuration | Differential, 100μA Open-Circuit Current | 4 | 0101 | | 0 1 0 1 | | |
| Not Used | Set These Bits to 0 | 6 | 000000 | | | 0 0 0 0 0 0 | |
| (4) Custom Thermocouple Data Pointer | Not Custom | 12 | 000000000000 | | | | 0 0 0 0 0 0 0 0 0 0 0 0 |

APPLICATIONS INFORMATION

RTD MEASUREMENTS

Table 25. RTD Channel Assignment Word

| | (1) RTD TYPE | | | | | (2) SENSE RESISTOR CHANNEL POINTER | | | | | (3) SENSOR CONFIGURATION | | | | (4) EXCITATION CURRENT | | | | (5) RTD STANDARD | | (6) CUSTOM RTD DATA POINTER | | | | | | | | | | | |
|-------------------|-----------------|----|----|----|----|---|----|----|----|----|--------------------------|----|-----------------|----|--------------------------|----|----|----|------------------|----|-----------------------------|----|---|---|---|-------------------------|---|---|---|---|---|---|
| | TABLE 26 | | | | | TABLE 27 | | | | | TABLE 28 | | | | TABLE 29 | | | | TABLE 30 | | TABLES 72 TO 74 | | | | | | | | | | | |
| Measurement Class | 31 | 30 | 29 | 28 | 27 | 26 | 25 | 24 | 23 | 22 | 21 | 20 | 19 | 18 | 17 | 16 | 15 | 14 | 13 | 12 | 11 | 10 | 9 | 8 | 7 | 6 | 5 | 4 | 3 | 2 | 1 | 0 |
| RTD | Type = 10 to 18 | | | | | R _{SENSE} Channel Assignment [4:0] | | | | | 2, 3, 4 Wire | | Excitation Mode | | Excitation Current [3:0] | | | | Standard [1:0] | | Custom Address [5:0] | | | | | Custom Length – 1 [5:0] | | | | | | |

Channel Assignment – RTD

For each RTD tied to the LTC2983, a 32-bit channel assignment word is programmed into a memory location corresponding to the channel the sensor is tied to (see Table 25). This word includes (1) RTD type, (2) sense resistor channel pointer, (3) sensor configuration, (4) excitation current, (5) RTD standard, and (6) custom RTD data pointer.

(1) RTD Type

The RTD type is determined by the first five input bits B31 to B27 as shown in Table 26. Linearization coefficients for RTD types PT-10, PT-50, PT-100, PT-200, PT-500, PT-1000, and NI-120 with selectable common standards ($\alpha = 0.003850$, $\alpha = 0.003911$, $\alpha = 0.003916$, and $\alpha = 0.003926$) are built into the device. If custom RTDs are used, RTD Custom can be selected. In this case, user specific data can be stored in the on-chip RAM starting at the address defined by the custom RTD data pointers.

Table 26. RTD Type

| (1) RTD TYPE | | | | | RTD TYPE |
|--------------|-----|-----|-----|-----|-------------------------------|
| B31 | B30 | B29 | B28 | B27 | |
| 0 | 1 | 0 | 1 | 0 | RTD PT-10 |
| 0 | 1 | 0 | 1 | 1 | RTD PT-50 |
| 0 | 1 | 1 | 0 | 0 | RTD PT-100 |
| 0 | 1 | 1 | 0 | 1 | RTD PT-200 |
| 0 | 1 | 1 | 1 | 0 | RTD PT-500 |
| 0 | 1 | 1 | 1 | 1 | RTD PT-1000 |
| 1 | 0 | 0 | 0 | 0 | RTD 1000 ($\alpha=0.00375$) |
| 1 | 0 | 0 | 0 | 1 | RTD NI-120 |
| 1 | 0 | 0 | 1 | 0 | RTD Custom |

(2) Sense Resistor Channel Pointer

RTD measurements are performed ratiometrically relative to a known R_{SENSE} resistor. The sense resistor channel pointer field indicates the differential channel the sense resistor is tied to for the RTD (see Table 27). Sense resistors are always measured differentially.

Table 27. Sense Resistor Channel Pointer

| (2) SENSE RESISTOR CHANNEL POINTER | | | | | SENSE RESISTOR CHANNEL |
|------------------------------------|-----|-----|-----|-----|------------------------|
| B26 | B25 | B24 | B23 | B22 | |
| 0 | 0 | 0 | 0 | 0 | Invalid |
| 0 | 0 | 0 | 0 | 1 | Invalid |
| 0 | 0 | 0 | 1 | 0 | CH2-CH1 |
| 0 | 0 | 0 | 1 | 1 | CH3-CH2 |
| 0 | 0 | 1 | 0 | 0 | CH4-CH3 |
| 0 | 0 | 1 | 0 | 1 | CH5-CH4 |
| 0 | 0 | 1 | 1 | 0 | CH6-CH5 |
| 0 | 0 | 1 | 1 | 1 | CH7-CH6 |
| 0 | 1 | 0 | 0 | 0 | CH8-CH7 |
| 0 | 1 | 0 | 0 | 1 | CH9-CH8 |
| 0 | 1 | 0 | 1 | 0 | CH10-CH9 |
| 0 | 1 | 0 | 1 | 1 | CH11-CH10 |
| 0 | 1 | 1 | 0 | 0 | CH12-CH11 |
| 0 | 1 | 1 | 0 | 1 | CH13-CH12 |
| 0 | 1 | 1 | 1 | 0 | CH14-CH13 |
| 0 | 1 | 1 | 1 | 1 | CH15-CH14 |
| 1 | 0 | 0 | 0 | 0 | CH16-CH15 |
| 1 | 0 | 0 | 0 | 1 | CH17-CH16 |
| 1 | 0 | 0 | 1 | 0 | CH18-CH17 |
| 1 | 0 | 0 | 1 | 1 | CH19-CH18 |
| 1 | 0 | 1 | 0 | 0 | CH20-CH19 |
| All Other Combinations | | | | | Invalid |

APPLICATIONS INFORMATION

(3) Sensor Configuration

The sensor configuration field is used to define various RTD properties. Configuration bits B20 and B21 determine if the RTD is a 2, 3, or 4 wire type (see Table 28).

The simplest configuration is the 2-wire configuration. While this setup is simple, parasitic errors due to IR drops in the leads result in systematic temperature errors. The 3-wire configuration cancels RTD lead resistance errors (if the lines are equal resistance) by applying two matched current sources to the RTD, one per lead. Mismatches in the two current sources are removed through transparent background calibration. 4-wire RTDs remove unbalanced RTD lead resistance by measuring directly across the

sensor using a high impedance Kelvin sensing. 4-wire measurements with Kelvin R_{SENSE} are useful in applications where sense resistor wiring parasitics can lead to errors; this is especially useful for low resistance PT-10 type RTDs. In this case, both the RTD and sense resistor have Kelvin sensing connections.

The next sensor configuration bits (B18 and B19) determine the excitation current mode. These bits are used to enable R_{SENSE} sharing, where one sense resistor is used for multiple 2-, 3-, and/or 4-wire RTDs. In this case, the RTD ground connection is internal and each RTD points to the same R_{SENSE} channel.

Table 28. RTD Sensor Configuration Selection

| (3) SENSE CONFIGURATION | | | | MEASUREMENT MODE | | | | | BENEFITS | | | |
|-------------------------|-----|-----------------|-----|----------------------------|-------------------|-------------------------|------------------------|--------------------------|-------------------------------------|--------------------------------------|--|-------------------------------------|
| NUMBER OF WIRES | | EXCITATION MODE | | NUMBER OF WIRES | GROUND CONNECTION | CURRENT SOURCE ROTATION | SENSE RESISTOR SHARING | RTDs POSSIBLE PER DEVICE | CANCELS RTD MATCHED LEAD RESISTANCE | CANCELS RTD MISMATCH LEAD RESISTANCE | CANCELS PARASITIC THERMOCOUPLE EFFECTS | CANCELS R_{SENSE} LEAD RESISTANCE |
| B21 | B20 | B19 | B18 | | | | | | | | | |
| 0 | 0 | 0 | 0 | 2-Wire | External | No | No | 5 | | | | |
| 0 | 0 | 0 | 1 | 2-Wire | Internal | No | Yes | 9 | | | | |
| 0 | 1 | 0 | 0 | 3-Wire | External | No | No | 5 | • | | | |
| 0 | 1 | 0 | 1 | 3-Wire | Internal | No | Yes | 9 | • | | | |
| 0 | 1 | 1 | X | Reserved | | | | | | | | |
| 1 | 0 | 0 | 0 | 4-Wire | External | No | No | 4 | • | • | | |
| 1 | 0 | 0 | 1 | 4-Wire | Internal | No | Yes | 6 | • | • | | |
| 1 | 0 | 1 | 0 | 4-Wire | Internal | Yes | Yes | 6 | • | • | • | |
| 1 | 0 | 1 | 1 | Reserved | | | | | | | | |
| 1 | 1 | 0 | 0 | 4-Wire, Kelvin R_{SENSE} | External | No | No | 4 | • | • | | • |
| 1 | 1 | 0 | 1 | 4-Wire, Kelvin R_{SENSE} | Internal | No | Yes | 5 | • | • | | • |
| 1 | 1 | 1 | 0 | 4-Wire, Kelvin R_{SENSE} | Internal | Yes | Yes | 5 | • | • | • | • |
| 1 | 1 | 1 | 1 | Reserved | | | | | | | | |

APPLICATIONS INFORMATION

Bits B18 and B19 are also used to enable excitation current rotation to automatically remove parasitic thermocouple effects. Parasitic thermocouple effects may arise from the physical connected between the RTD and the measurement instrument. This mode is available for all 4-wire configurations using internal current source excitation.

(4) Excitation Current

The next field in the channel assignment word (B17 to B14) controls the magnitude of the excitation current applied to the RTD (see Table 29). The current selected is the total current flowing through the RTD independent of the wiring configuration. The R_{SENSE} current is 2x the sensor excitation current for 3-wire RTDs.

In order to prevent soft or hard faults, select a current such that the maximum voltage drop across the sensor or sense resistor is nominally 1.0V. For example, if R_{SENSE} is 10k Ω and the RTD is a PT-100, select an excitation current of 100 μ A for 2-wire and 4-wire RTDs and select 50 μ A for a 3-wire RTD. Alternatively, using a 1k Ω sense resistor with a PT-100 RTD allows 500 μ A excitation for any wiring configuration.

Table 29. Total Excitation Current for All RTD Wire Types

| (4) EXCITATION CURRENT | | | | |
|------------------------|-----|-----|-----|-------------|
| B17 | B16 | B15 | B14 | CURRENT |
| 0 | 0 | 0 | 0 | External |
| 0 | 0 | 0 | 1 | 5 μ A |
| 0 | 0 | 1 | 0 | 10 μ A |
| 0 | 0 | 1 | 1 | 25 μ A |
| 0 | 1 | 0 | 0 | 50 μ A |
| 0 | 1 | 0 | 1 | 100 μ A |
| 0 | 1 | 1 | 0 | 250 μ A |
| 0 | 1 | 1 | 1 | 500 μ A |
| 1 | 0 | 0 | 0 | 1mA |

(5) RTD Standard

Bits B13 and B12 set the RTD standard used and the corresponding Callendar-Van Dusen constants (shown in Table 30).

(6) Custom RTD Data Pointer

In the case where an RTD not listed in Table 30 is used, a custom RTD table may be entered into the LTC2983.

See Custom RTD section near the end of this data sheet for more information.

Table 30. RTD Standards: $RT = R0 \cdot (1 + a \cdot T + b \cdot T^2 + (T - 100^\circ\text{C}) \cdot c \cdot T^3)$ for $T < 0^\circ\text{C}$, $RT = R0 \cdot (1 + a \cdot T + b \cdot T^2)$ for $T > 0^\circ\text{C}$

| (5) STANDARD | | STANDARD | ALPHA | a | b | c |
|--------------|-----|-------------------|----------|--------------|---------------|---------------|
| B13 | B12 | | | | | |
| 0 | 0 | European Standard | 0.00385 | 3.908300E-03 | -5.775000E-07 | -4.183000E-12 |
| 0 | 1 | American | 0.003911 | 3.969200E-03 | -5.849500E-07 | -4.232500E-12 |
| 1 | 0 | Japanese | 0.003916 | 3.973900E-03 | -5.870000E-07 | -4.400000E-12 |
| 1 | 1 | ITS-90 | 0.003926 | 3.984800E-03 | -5.870000E-07 | -4.000000E-12 |
| X | X | RTD1000-375 | 0.00375 | 3.810200E-03 | -6.018880E-07 | -6.000000E-12 |
| X | X | *NI-120 | N/A | N/A | N/A | N/A |

*NI-120 uses table based data.

APPLICATIONS INFORMATION

Fault Reporting – RTD

Each sensor type has unique fault reporting mechanism indicated in the most significant byte of the data output word. Table 31 shows faults reported in the measurement of RTDs.

Bit D31 indicates the RTD or R_{SENSE} is open, shorted, or not plugged in. This is a hard fault and -999°C or $^{\circ}\text{F}$ is reported. Bit D30 indicates a bad ADC reading. This can be a result of either a broken (open) sensor or an excessive noise event (ESD or static discharge into the sensor path). This

is a hard error and -999°C or $^{\circ}\text{F}$ is reported. In the case of an excessive noise event, the device should recover and the following conversions will be valid if the noise was a random infrequent event. Bits D29 and D28 are not used for RTDs. Bits D27 and D26 indicate over or under temperature limits (see Table 32). The calculated temperature is reported, but the accuracy may be compromised. Bit D25 indicates the absolute voltage measured by the ADC is beyond its normal operating range. If an RTD is used as the cold junction element, any hard or soft error is also flagged in the thermocouple result.

Table 31. RTD Fault Reporting

| BIT | FAULT | ERROR TYPE | DESCRIPTION | OUTPUT RESULT |
|-----|-----------------------|------------|--|--|
| D31 | Sensor Hard Fault | Hard | Open or Short RTD or R_{SENSE} | -999°C or $^{\circ}\text{F}$ |
| D30 | Hard ADC-Out-of-Range | Hard | Bad ADC Reading (Could Be Large External Noise Event) | -999°C or $^{\circ}\text{F}$ |
| D29 | Not Used for RTDs | N/A | Always 0 | Valid Reading |
| D28 | Not Used for RTDs | N/A | Always 0 | Valid Reading |
| D27 | Sensor Over Range | Soft | $T >$ High Temp Limit (See Table 32) | Suspect Reading |
| D26 | Sensor Under Range | Soft | $T <$ Low Temp Limit (See Table 32) | Suspect Reading |
| D25 | ADC Out-of-Range | Soft | ADC Absolute Input Voltage Is Beyond $\pm 1.125 \cdot V_{REF}/2$ | Suspect Reading |
| D24 | Valid | N/A | Result Valid (Should Be 1) Discard Results if 0 | Valid Reading |

Table 32. Voltage and Resistance Ranges

| RTD TYPE | MIN Ω | MAX Ω | LOW TEMP LIMIT $^{\circ}\text{C}$ | HIGH TEMP LIMIT $^{\circ}\text{C}$ |
|--------------|--------------------|---------------------|-----------------------------------|------------------------------------|
| PT-10 | 1.95 | 34.5 | -200 | 850 |
| PT-50 | 9.75 | 172.5 | -200 | 850 |
| PT-100 | 19.5 | 345 | -200 | 850 |
| PT-200 | 39 | 690 | -200 | 850 |
| PT-500 | 97.5 | 1725 | -200 | 850 |
| PT-1000 | 195 | 3450 | -200 | 850 |
| NI-120 | 66.6 | 380.3 | -80 | 260 |
| Custom Table | Lowest Table Entry | Highest Table Entry | Lowest Table Entry | Highest Table Entry |

APPLICATIONS INFORMATION

Sense Resistor

Table 33. Sense Resistor Channel Assignment Word

| | (1) SENSOR TYPE | | | | | (2) SENSE RESISTOR VALUE (Ω) | | | | | | | | | | | | | | | | | | | | | | | | | | |
|-------------------|-----------------|----|----|----|----|--|----|----|----|----|----|----|----|----|----|----|----|----|----|----|----|----|---|---|---|---|---|---|---|---|---|---|
| | FIGURE 36 | | | | | FIGURE 40 | | | | | | | | | | | | | | | | | | | | | | | | | | |
| Measurement Class | 31 | 30 | 29 | 28 | 27 | 26 | 25 | 24 | 23 | 22 | 21 | 20 | 19 | 18 | 17 | 16 | 15 | 14 | 13 | 12 | 11 | 10 | 9 | 8 | 7 | 6 | 5 | 4 | 3 | 2 | 1 | 0 |
| Sense Resistor | Type = 29 | | | | | Sense Resistor Value (17, 10) Up to $\approx 131,072\Omega$ with $1/1024\Omega$ Resolution | | | | | | | | | | | | | | | | | | | | | | | | | | |

Channel Assignment

For each sense resistor tied to the LTC2983, a 32-bit channel assignment word is programmed into a memory location corresponding to the channel the sensor is tied to (see Table 33). This word includes (1) sense resistor selection and (2) sense resistor value.

(1) Sensor Type

The sense resistor is selected by setting the first 5 input bits, B31 to B27, to 11101 (see Table 34).

Table 34. Sense Resistor Selection

| (1) SENSOR TYPE | | | | | SENSOR TYPE |
|-----------------|-----|-----|-----|-----|----------------|
| B31 | B30 | B29 | B28 | B27 | |
| 1 | 1 | 1 | 0 | 1 | Sense Resistor |

(2) Sense Resistor Value

The last field in the channel assignment word (B26 to B0) sets the value of the sense resistor within the range 0 to $131,072\Omega$ with $1/1024\Omega$ precision (see Table 35). The top 17 bits (B26 to B10) create the integer and bits B9 to B0 create the fraction of the sense resistor value.

Example: 2-Wire RTD

The simplest RTD configuration is the 2-wire configuration, 2-wire RTDs follow the general convention shown in Figure 7. They require only two connections per RTD and

can be tied directly to 2-lead RTD elements. The disadvantages of this topology are errors due to parasitic lead resistance. If sharing is not selected (1 R_{SENSE} per RTD), then CH_{RTD} should be grounded. The ground connection should be removed if sharing is enabled (1 R_{SENSE} for multiple RTDs).

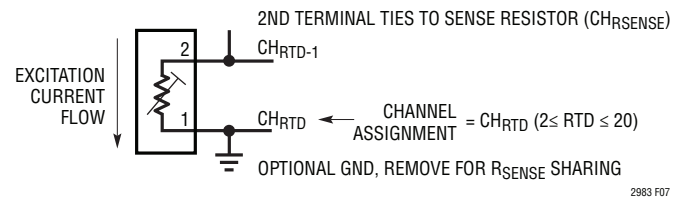

2983 F07

Figure 7. 2-Wire RTD Channel Assignment Convention

Sense resistor channel assignments follow the general convention shown in Figure 8. The sense resistor is tied between CH_{RSNSE} and $CH_{RSNSE-1}$, where CH_{RSNSE} is tied to the 2nd terminal of the RTD. Channel assignment data (see Table 33) is mapped into a memory location corresponding to CH_{RSNSE} .

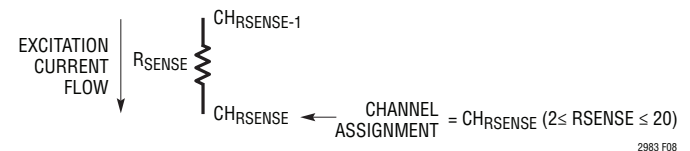

2983 F08

Figure 8. Sense Resistor Channel Assignment Convention for 2-Wire RTDs

Table 35. Example Sense Resistor Values

| | (2) SENSE RESISTOR VALUE (Ω) | | | | | | | | | | | | | | | | | | | | | | | | | | | | | | | |
|--------------------|---------------------------------------|----------|----------|----------|----------|----------|----------|-------|-------|-------|-------|-------|-------|-------|-------|-------|-------|----------|----------|----------|----------|----------|----------|----------|----------|----------|-----------|--|--|--|--|--|
| | B26 | B25 | B24 | B23 | B22 | B21 | B20 | B19 | B18 | B17 | B16 | B15 | B14 | B13 | B12 | B11 | B10 | B9 | B8 | B7 | B6 | B5 | B4 | B3 | B2 | B1 | B0 | | | | | |
| Example R | 2^{16} | 2^{15} | 2^{14} | 2^{13} | 2^{12} | 2^{11} | 2^{10} | 2^9 | 2^8 | 2^7 | 2^6 | 2^5 | 2^4 | 2^3 | 2^2 | 2^1 | 2^0 | 2^{-1} | 2^{-2} | 2^{-3} | 2^{-4} | 2^{-5} | 2^{-6} | 2^{-7} | 2^{-8} | 2^{-9} | 2^{-10} | | | | | |
| 10,000.2 Ω | 0 | 0 | 0 | 1 | 0 | 0 | 1 | 1 | 1 | 0 | 0 | 0 | 1 | 0 | 0 | 0 | 0 | 0 | 0 | 1 | 1 | 0 | 0 | 1 | 1 | 0 | 1 | | | | | |
| 99.99521k Ω | 1 | 1 | 0 | 0 | 0 | 0 | 1 | 1 | 0 | 1 | 0 | 0 | 1 | 1 | 0 | 1 | 1 | 0 | 0 | 1 | 1 | 0 | 1 | 0 | 1 | 1 | 1 | | | | | |
| 1.0023k Ω | 0 | 0 | 0 | 0 | 0 | 0 | 0 | 1 | 1 | 1 | 1 | 1 | 0 | 1 | 0 | 1 | 0 | 0 | 1 | 0 | 0 | 1 | 1 | 0 | 0 | 1 | 1 | | | | | |

2983fa

APPLICATIONS INFORMATION

Example: 2-Wire RTDs with Shared R_{SENSE}

Figure 9 shows a typical temperature measurement system using multiple 2-wire RTDs. In this example, a PT-1000 RTD ties to CH17 and CH18 and an NI-120 RTD ties to CH19 and CH20. Using this configuration, the LTC2983 can digitize up to nine 2-wire RTDs with a single sense resistor.

RTD #1 sensor type and configuration data are assigned to CH₁₈. 32 bits of binary configuration data are mapped directly into memory locations 0x244 to 0x247 (see Table 36). RTD #2 sensor type and configuration data are assigned to CH₂₀. 32-bits of binary configuration data

are mapped directly into memory locations 0x24C to 0x24F (see Table 37). The sense resistor is assigned to CH₁₆. The user-programmable value of this resistor is 5001.5Ω. 32 bits of binary configuration data are mapped directly into memory locations 0x23C to 0x23F (see Table 38).

A conversion is initiated on CH₁₈ by writing 10010010 into memory location 0x000. Once the conversion is complete, the INTERRUPT pin goes HIGH and memory location 0x000 becomes 01010010. The resulting temperature in °C can be read from memory locations 0x054 to 0x057 (corresponding to CH₁₈). A conversion can be initiated and read from CH₂₀ in a similar fashion.

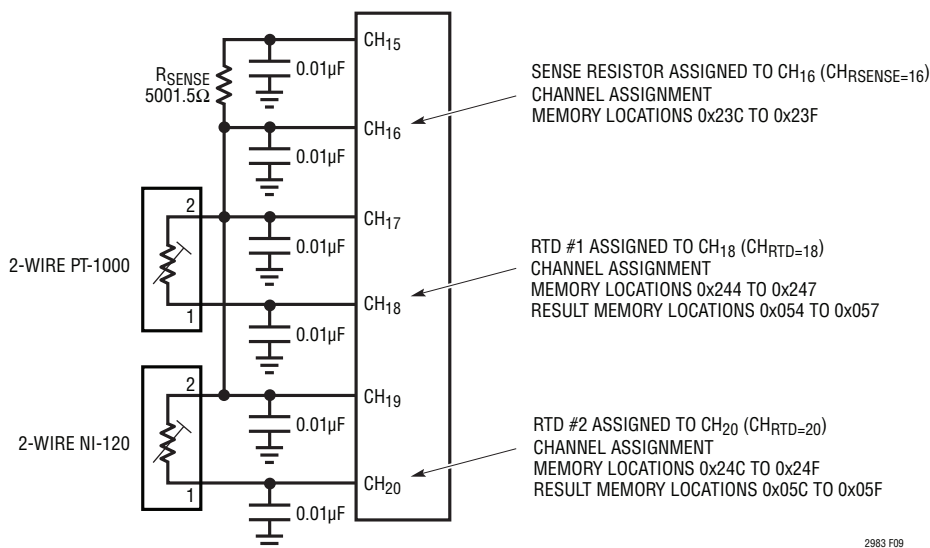

Figure 9. Shared 2-Wire RTD Example

Table 36. Channel Assignment Data for 2-Wire RTD #1 (PT-1000, R_{SENSE} on CH₁₆, 2-Wire, Shared R_{SENSE}, 10μA Excitation Current, α = 0.003916 Standard)

| CONFIGURATION FIELD | DESCRIPTION | # BITS | BINARY DATA | MEMORY ADDRESS 0x244 | MEMORY ADDRESS 0x245 | MEMORY ADDRESS 0x246 | MEMORY ADDRESS 0x247 |
|------------------------------------|---------------------------------------|--------|--------------|----------------------|----------------------|----------------------|-------------------------|
| (1) RTD TYPE | PT-1000 | 5 | 01111 | 0 1 1 1 1 | | | |
| (2) Sense Resistor Channel Pointer | CH ₁₆ | 5 | 10000 | | 1 0 0 0 0 | | |
| (3) Sensor Configuration | 2-Wire with Shared R _{SENSE} | 4 | 0001 | | | 0 0 0 1 | |
| (4) Excitation Current | 10μA | 4 | 0010 | | | 0 0 1 0 | |
| (5) Standard | Japanese, α = 0.003916 | 2 | 10 | | | 1 0 | |
| (6) Custom RTD Data Pointer | Not Custom | 12 | 000000000000 | | | | 0 0 0 0 0 0 0 0 0 0 0 0 |

2983fa

APPLICATIONS INFORMATION

Table 37. Channel Assignment Data for 2-Wire RTD #2 (NI-120, R_{SENSE} on CH₁₆, 2-Wire, Shared R_{SENSE}, 100µA Excitation Current)

| CONFIGURATION FIELD | DESCRIPTION | # BITS | BINARY DATA | MEMORY ADDRESS 0x24C | MEMORY ADDRESS 0x24D | MEMORY ADDRESS 0x24E | MEMORY ADDRESS 0x24F |
|------------------------------------|---------------------------------------|--------|--------------|----------------------|----------------------|----------------------|-------------------------|
| (1) RTD TYPE | NI-120 | 5 | 10001 | 1 0 0 0 1 | | | |
| (2) Sense Resistor Channel Pointer | CH ₁₆ | 5 | 10000 | | 1 0 0 0 0 | | |
| (3) Sensor Configuration | 2-Wire with Shared R _{SENSE} | 4 | 0001 | | | 0 0 0 1 | |
| (4) Excitation Current | 100µA | 4 | 0101 | | | | 0 1 0 1 |
| (5) Standard | European α = 0.00385 | 2 | 00 | | | | 0 0 |
| (6) Custom RTD Data Pointer | Not Custom | 12 | 000000000000 | | | | 0 0 0 0 0 0 0 0 0 0 0 0 |

Table 38. Channel Assignment Data for Sense Resistor (Value = 5001.5Ω)

| CONFIGURATION FIELD | DESCRIPTION | # BITS | BINARY DATA | MEMORY ADDRESS 0x23C | MEMORY ADDRESS 0x23D | MEMORY ADDRESS 0x23E | MEMORY ADDRESS 0x23F |
|--------------------------|----------------|--------|-----------------------------|----------------------|---|----------------------|----------------------|
| (1) Sensor Type | Sense Resistor | 5 | 11101 | 1 1 1 0 1 | | | |
| (2) Sense Resistor Value | 5001.5Ω | 27 | 000010011100010011000000000 | | 0 0 0 0 1 0 0 1 1 1 0 0 0 1 0 0 1 1 0 0 0 0 0 0 0 0 0 0 | | |

Example: 3-Wire RTD

3-wire RTD channel assignments follow the general convention shown in Figure 10. Terminals 1 and 2 tie to the input/excitation current sources and terminal 3 connects to the sense resistor. Channel assignment data is mapped to memory locations corresponding to CH_{RTD}.

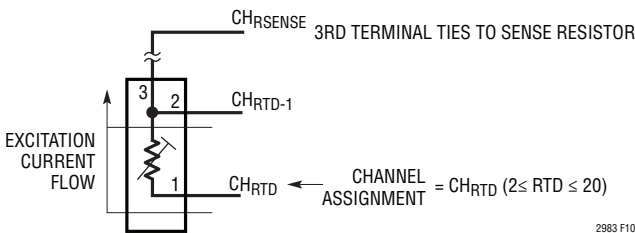

Figure 10. 3-Wire RTD Channel Assignment Convention

Sense resistor channel assignments follow the general convention shown in Figure 11. The sense resistor is tied between CH_{RSENSE} and CH_{RSENSE-1}, where CH_{RSENSE} is tied to the 3rd terminal of the RTD and CH_{RSENSE-1} is tied to ground (or left floating for R_{SENSE} sharing). Channel assignment data (see Table 33) is mapped into the memory location corresponding to CH_{RSENSE}.

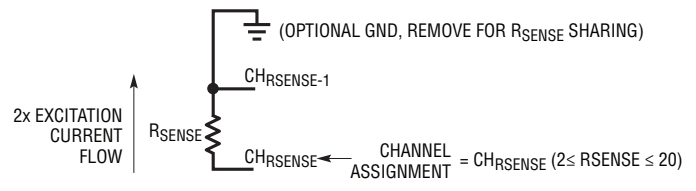

Figure 11. 3-Wire Sense Resistor Channel Assignment Convention for 3-Wire RTDs

APPLICATIONS INFORMATION

Figure 12 shows a typical temperature measurement system using a 3-wire RTD. In this example, a 3-wire RTD's terminals tie to CH₉, CH₈, and CH₇. The sense resistor ties to CH₇ and CH₆. The sense resistor and RTD connect together at CH₇.

The 3-wire RTD reduces the errors associated with parasitic lead resistance by applying excitation current to each RTD input. This first order cancellation removes matched lead resistance errors. This cancellation does not remove

errors due to thermocouple effects or mismatched lead resistances. The RTD sensor type and configuration data are assigned to CH₉. 32 bits of binary configuration data are mapped directly into memory locations 0x220 to 0x223 (see Table 39). The sense resistor is assigned to CH₇. The user-programmable value of this resistor is 12150.39Ω. 32 bits of binary configuration data are mapped directly into memory locations 0x218 to 0x21B (see Table 40).

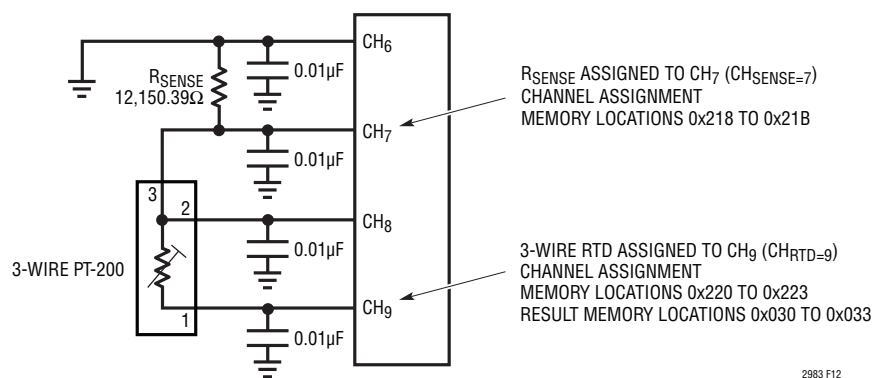

Figure 12. 3-Wire RTD Example

Table 39. Channel Assignment Data for 3-Wire RTD (PT-200, R_{SENSE} on CH₇, 3-Wire, 50μA Excitation Current, α = 0.003911 Standard)

| CONFIGURATION FIELD | DESCRIPTION | # BITS | BINARY DATA | MEMORY ADDRESS 0x220 | MEMORY ADDRESS 0x221 | MEMORY ADDRESS 0x222 | MEMORY ADDRESS 0x223 |
|------------------------------------|------------------------|--------|--------------|----------------------|----------------------|----------------------|-------------------------|
| (1) RTD TYPE | PT-200 | 5 | 01101 | 0 1 1 0 1 | | | |
| (2) Sense Resistor Channel Pointer | CH ₇ | 5 | 00111 | | 0 0 1 1 1 | | |
| (3) Sensor Configuration | 3-Wire | 4 | 0100 | | 0 1 0 0 | | |
| (4) Excitation Current | 50μA | 4 | 0100 | | 0 1 0 0 | | |
| (5) Standard | American, α = 0.003911 | 2 | 01 | | | 0 1 | |
| (6) Custom RTD Data Pointer | Not Custom | 12 | 000000000000 | | | | 0 0 0 0 0 0 0 0 0 0 0 0 |

Table 40. Channel Assignment Data for Sense Resistor (Value = 12150.39Ω)

| CONFIGURATION FIELD | DESCRIPTION | # BITS | BINARY DATA | MEMORY ADDRESS 0x218 | MEMORY ADDRESS 0x219 | MEMORY ADDRESS 0x21A | MEMORY ADDRESS 0x21B |
|--------------------------|----------------|--------|-----------------------------|---|----------------------|----------------------|----------------------|
| (1) Sensor Type | Sense Resistor | 5 | 11101 | 1 1 1 0 1 | | | |
| (2) Sense Resistor Value | 12150.39Ω | 27 | 000101111011101100110001111 | 0 0 0 1 0 1 1 1 1 0 1 1 1 0 1 1 0 0 1 1 0 0 1 1 1 0 | | | |

APPLICATIONS INFORMATION

A conversion is initiated on CH₉ by writing 10001001 into memory location 0x000. Once the conversion is complete, the INTERRUPT pin goes HIGH and memory location 0x000 becomes 01001001. The resulting temperature in °C can be read from memory locations 0x030 to 0x033 (corresponding to CH₉).

Example: Standard 4-Wire RTD (No Rotation or R_{SENSE} Sharing)

Standard 4-wire RTD channel assignments follow the general convention shown in Figure 13. Terminal 1 is tied to ground, terminals 2 and 3 (Kelvin sensed signal) tie to CH_{RTD} and CH_{RTD-1}, and the 4th terminal ties to the sense resistor. Channel assignment data (see Table 25) is mapped to memory locations corresponding to CH_{RTD}.

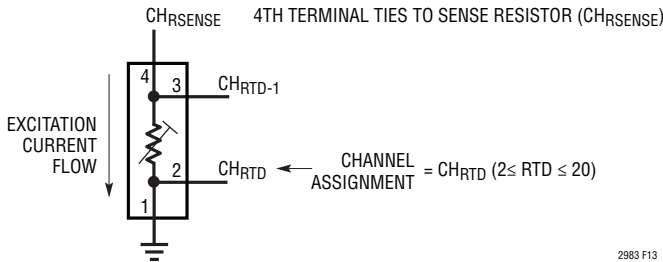

Figure 13. 4-Wire RTD Channel Assignment Convention

Sense resistor channel assignments follow the general convention shown in Figure 14. The sense resistor is tied between CH_{RSENSE} and CH_{SENSE-1}, where CH_{RSENSE} is tied to the 4th terminal of the RTD. Channel assignment data (see Table 33) is mapped into a memory location corresponding to CH_{RSENSE}.

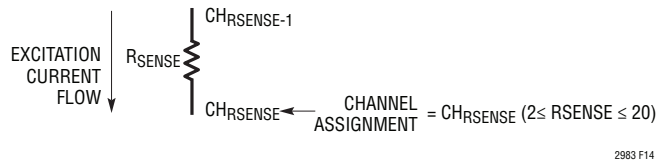

Figure 14. Sense Resistor Channel Assignment Convention for 4-Wire RTDs

APPLICATIONS INFORMATION

Figure 15 shows a typical temperature measurement system using a 4-wire RTD. In this example, a 4-wire RTD's terminals tie to GND, CH₁₃, CH₁₂, and CH₁₁. The sense resistor ties to CH₁₁ and CH₁₀. The sense resistor and RTD share a common connection at CH₁₁. The RTD sensor type and configuration data are assigned to CH₁₃. 32 bits of binary configuration data are mapped directly into memory locations 0x230 to 0x233 (see Table 41). The sense resistor is assigned to CH₁₁. The user programmable value of this resistor is 5000.2Ω.

32 bits of binary configuration data are mapped directly into memory locations 0x228 to 0x22B (see Table 42).

A conversion is initiated on CH₁₃ by writing 10001101 into the data byte at memory location 0x000. Once the conversion is complete, the INTERRUPT pin goes HIGH and memory location 0x000 becomes 01001101. The resulting temperature in °C can be read from memory locations 0x040 to 0x043 (corresponding to CH₁₃).

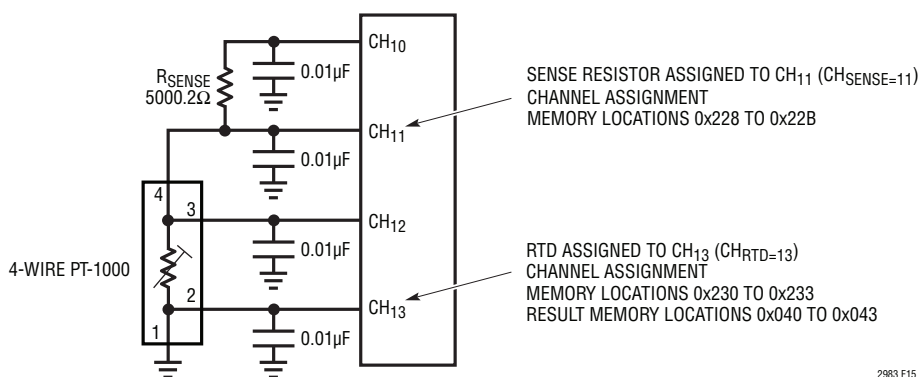

Figure 15. Standard 4-Wire RTD Example

Table 41. Channel Assignment Data for 4-Wire RTD (PT-1000, R_{SENSE} on CH₁₁, Standard 4-Wire, 25μA Excitation Current, α = 0.00385 Standard)

| CONFIGURATION FIELD | DESCRIPTION | # BITS | BINARY DATA | MEMORY ADDRESS 0x230 | MEMORY ADDRESS 0x231 | MEMORY ADDRESS 0x232 | MEMORY ADDRESS 0x233 |
|------------------------------------|-----------------------------|--------|--------------|----------------------|----------------------|----------------------|-------------------------|
| (1) RTD TYPE | PT-1000 | 5 | 01111 | 0 1 1 1 1 | | | |
| (2) Sense Resistor Channel Pointer | CH ₁₁ | 5 | 01011 | | 0 1 0 1 1 | | |
| (3) Sensor Configuration | 4-Wire, No Rotate, No Share | 4 | 1000 | | | 1 0 0 0 | |
| (4) Excitation Current | 25μA | 4 | 0011 | | | 0 0 1 1 | |
| (5) Standard | European, α=0.00385 | 2 | 00 | | | 0 0 | |
| (6) Custom RTD Data Pointer | Not Custom | 12 | 000000000000 | | | | 0 0 0 0 0 0 0 0 0 0 0 0 |

Table 42. Channel Assignment Data for Sense Resistor (Value = 5000.2Ω)

| CONFIGURATION FIELD | DESCRIPTION | # BITS | BINARY DATA | MEMORY ADDRESS 0x228 | MEMORY ADDRESS 0x229 | MEMORY ADDRESS 0x22A | MEMORY ADDRESS 0x22B |
|--------------------------|----------------|--------|-----------------------------|----------------------|---|----------------------|----------------------|
| (1) Sensor Type | Sense Resistor | 5 | 11101 | 1 1 1 0 1 | | | |
| (2) Sense Resistor Value | 5000.2Ω | 27 | 000010011100010000011001100 | | 0 0 0 0 1 0 0 1 1 1 0 0 0 1 0 0 0 0 0 0 1 1 0 0 1 1 0 0 | | |

2983fa

APPLICATIONS INFORMATION

Example: 4-Wire RTD with Rotation

One method to improve the accuracy of an RTD over the standard 4-wire implementation is by rotating the excitation current source. Parasitic thermocouple effects are automatically removed through autorotation. In order to perform autorotation, the 1st terminal of the RTD ties to CH_{RTD+1} instead of GND, as in the standard case. This allows the LTC2983 to automatically change the direction of the current source without the need for additional external components.

4-wire RTD with rotation channel assignments follow the general convention shown in Figure 16. Terminal 1 is tied to CH_{RTD+1} , terminals 2 and 3 (Kelvin sensed signal) tie to CH_{RTD} and CH_{RTD-1} , and the 4th terminal ties to the

sense resistor. Channel assignment data (see Table 25) is mapped to memory locations corresponding to CH_{RTD} .

Sense resistor channel assignments follow the general convention shown in Figure 17. The sense resistor is tied between CH_{RSENSE} and $CH_{RSENSE-1}$, where CH_{RSENSE} is tied to the 4th terminal of the RTD. Channel assignment data is mapped into a memory location corresponding to CH_{RSENSE} .

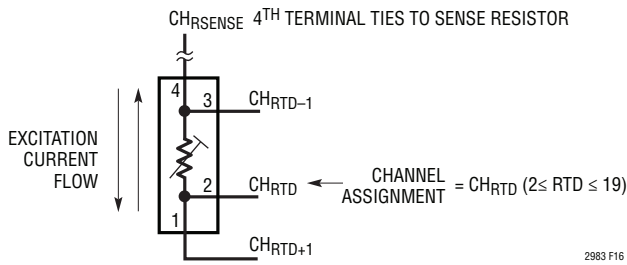

Figure 16. 4-Wire RTD Channel Assignment Convention

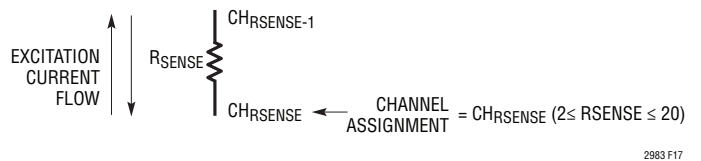

Figure 17. Sense Resistor Channel Assignment Convention for 4-Wire RTDs with Rotation

APPLICATIONS INFORMATION

Figure 18 shows a typical temperature measurement system using a rotating 4-wire RTD. In this example a 4-wire RTD's terminals tie to CH₁₇, CH₁₆, CH₁₅, and CH₆. The sense resistor is tied to CH₆ and CH₅. The sense resistor and RTD connect together at CH₆. The RTD sensor type and configuration data are assigned to CH₁₆. 32 bits of binary configuration data are mapped directly into memory locations 0x23C to 0x23F (see Table 43). The sense resistor is assigned to CH₆.

The user programmable value of this resistor is 10.0102k Ω . 32 bits of binary configuration data are mapped directly into memory locations 0x214 to 0x217 (see Table 44).

A conversion is initiated on CH₁₆ by writing 10010000 into memory location 0x000. Once the conversion is complete, the INTERRUPT pin goes HIGH and memory location 0x000 becomes 01010000. The resulting temperature in $^{\circ}\text{C}$ can be read from memory locations 0x04C to 0x04F (corresponding to CH₁₆).

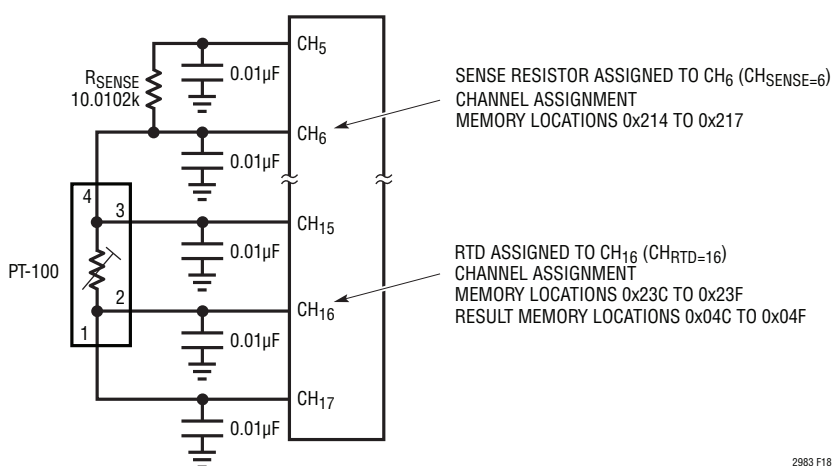

Figure 18. Rotating 4-Wire RTD Example

Table 43. Channel Assignment Data for Rotating 4-Wire RTD (PT-100, R_{SENSE} on CH₆, Rotating 4-Wire, 100 μA Excitation Current, $\alpha = 0.003911$ Standard)

| CONFIGURATION FIELD | DESCRIPTION | # BITS | BINARY DATA | MEMORY ADDRESS 0x23C | MEMORY ADDRESS 0x23D | MEMORY ADDRESS 0x23E | MEMORY ADDRESS 0x23F |
|------------------------------------|-----------------------------|--------|--------------|----------------------|----------------------|----------------------|-------------------------|
| (1) RTD TYPE | PT-100 | 5 | 01100 | 0 1 1 0 0 | | | |
| (2) Sense Resistor Channel Pointer | CH ₆ | 5 | 00110 | | 0 0 1 1 0 | | |
| (3) Sensor Configuration | 4-Wire with Rotation | 4 | 1010 | | 1 0 1 0 | | |
| (4) Excitation Current | 100 μA | 4 | 0101 | | | 0 1 0 1 | |
| (5) Standard | American, $\alpha=0.003911$ | 2 | 01 | | | 0 1 | |
| (6) Custom RTD Data Pointer | Not Custom | 12 | 000000000000 | | | | 0 0 0 0 0 0 0 0 0 0 0 0 |

Table 44. Channel Assignment Data for Sense Resistor (Value = 10.0102k Ω)

| CONFIGURATION FIELD | DESCRIPTION | # BITS | BINARY DATA | MEMORY ADDRESS 0x214 | MEMORY ADDRESS 0x215 | MEMORY ADDRESS 0x216 | MEMORY ADDRESS 0x217 |
|--------------------------|-------------------|--------|-----------------------------|----------------------|---|----------------------|----------------------|
| (1) Sensor Type | Sense Resistor | 5 | 11101 | 1 1 1 0 1 | | | |
| (2) Sense Resistor Value | 10.0102k Ω | 27 | 000100111000110100011001100 | | 0 0 0 1 0 0 1 1 1 0 0 0 1 1 0 1 0 0 0 1 1 0 0 1 1 0 0 | | |

2983fa

APPLICATIONS INFORMATION

Example: Multiple 4-Wire RTDs with Shared R_{SENSE}

Figure 19 shows a typical temperature measurement system using two 4-wire RTDs with a shared R_{SENSE}. The LTC2983 can support up to six 4-wire RTDs with a single sense resistor. In this example, the first 4-wire RTD's terminals tie to CH₁₇, CH₁₆, CH₁₅, and CH₆ and the 2nd ties to CH₂₀, CH₁₉, CH₁₈, and CH₆. The sense resistor ties to CH₅ and CH₆. The sense resistor and both RTDs connect together at CH₆. This channel assignment convention is identical to that of the rotating RTD. This

topology supports both rotated and non-rotated RTD excitations. Channel assignment data for each sensor is shown in Tables 45 to 47.

A conversion is initiated on CH₁₆ by writing 10010000 into memory location 0x000. Once the conversion is complete, the INTERRUPT pin goes HIGH and memory location 0x000 becomes 01010000. The resulting temperature in °C can be read from memory locations 0x04C to 0x04F (corresponding to CH₁₆). A conversion can be initiated and read from CH₁₉ in a similar fashion.

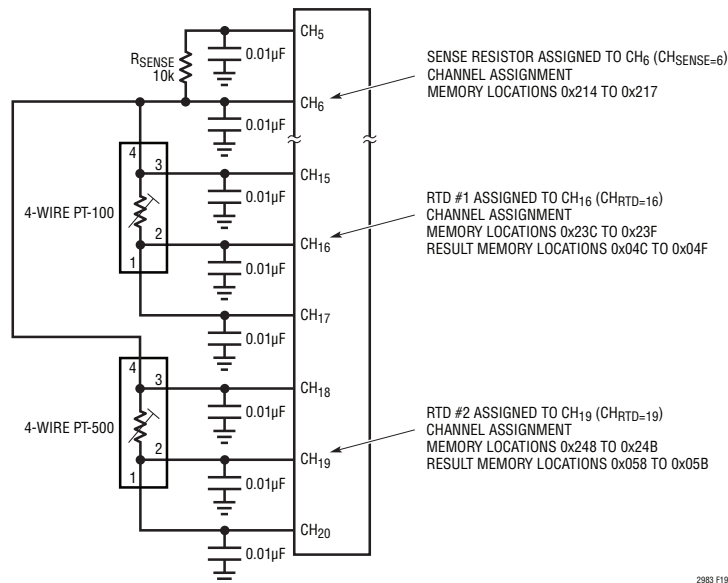

Figure 19. Shared R_{SENSE} 4-Wire RTD Example

Table 45. Channel Assignment Data for 4-Wire RTD #1 (PT-100, R_{SENSE} on CH₆, 4-Wire, Shared R_{SENSE}, Rotated 100µA Excitation Current, α = 0.003926 Standard)

| CONFIGURATION FIELD | DESCRIPTION | # BITS | BINARY DATA | MEMORY ADDRESS 0x23C | MEMORY ADDRESS 0x23D | MEMORY ADDRESS 0x23E | MEMORY ADDRESS 0x23F |
|------------------------------------|--------------------|--------|--------------|----------------------|----------------------|----------------------|-------------------------|
| (1) RTD TYPE | PT-100 | 5 | 01100 | 0 1 1 0 0 | | | |
| (2) Sense Resistor Channel Pointer | CH ₆ | 5 | 00110 | | 0 0 1 1 0 | | |
| (3) Sensor Configuration | 4-Wire Rotated | 4 | 1010 | | 1 0 1 0 | | |
| (4) Excitation Current | 100µA | 4 | 0101 | | | 0 1 0 1 | |
| (5) Standard | ITS-90, α=0.003926 | 2 | 11 | | | 1 1 | |
| (6) Custom RTD Data Pointer | Not Custom | 12 | 000000000000 | | | | 0 0 0 0 0 0 0 0 0 0 0 0 |

APPLICATIONS INFORMATION

Table 46. Channel Assignment Data for 4-Wire RTD #2 (PT-500, R_{SENSE} on CH_6 , 4-Wire, Rotated $50\mu A$ Excitation Current, $\alpha = 0.003911$ Standard)

| CONFIGURATION FIELD | DESCRIPTION | # BITS | BINARY DATA | MEMORY ADDRESS 0x248 | MEMORY ADDRESS 0x249 | MEMORY ADDRESS 0x24A | MEMORY ADDRESS 0x24B |
|------------------------------------|-----------------------------|--------|--------------|----------------------|----------------------|----------------------|-------------------------|
| (1) RTD TYPE | PT-500 | 5 | 01110 | 0 1 1 1 0 | | | |
| (2) Sense Resistor Channel Pointer | CH_6 | 5 | 00110 | | 0 0 1 1 0 | | |
| (3) Sensor Configuration | 4-Wire Shared, No Rotation | 4 | 1001 | | 1 0 0 1 | | |
| (4) Excitation Current | $50\mu A$ | 4 | 0100 | | | 0 1 0 0 | |
| (5) Standard | American, $\alpha=0.003911$ | 2 | 01 | | | 0 1 | |
| (6) Custom RTD Data Pointer | Not Custom | 12 | 000000000000 | | | | 0 0 0 0 0 0 0 0 0 0 0 0 |

Table 47. Channel Assignment Data for Sense Resistor (Value = $10.000k\Omega$)

| CONFIGURATION FIELD | DESCRIPTION | # BITS | BINARY DATA | MEMORY ADDRESS 0x214 | MEMORY ADDRESS 0x215 | MEMORY ADDRESS 0x216 | MEMORY ADDRESS 0x217 |
|--------------------------|-----------------|--------|------------------------------|----------------------|---|----------------------|----------------------|
| (1) Sensor Type | Sense Resistor | 5 | 11101 | 1 1 1 0 1 | | | |
| (2) Sense Resistor Value | $10.000k\Omega$ | 27 | 0001001110001000000000000000 | | 0 0 0 1 0 0 1 1 1 0 0 0 1 0 0 0 0 0 0 0 0 0 0 0 0 0 0 | | |

Example: 4-Wire RTD with Kelvin R_{SENSE}

It is possible to cancel the parasitic lead resistance in the sense resistors by configuring the 4-wire RTD with a 4-wire (Kelvin connected) sense resistor. This is useful when using a PT-10 or PT-50 with a small valued R_{SENSE} or when the sense resistor is remotely located or in applications requiring extreme precision.

The 4-wire RTD channel assignments follow the general conventions previously defined (Figures 14 and 16) for a standard 4-wire RTD. The sense resistor follows the convention shown in Figure 20.

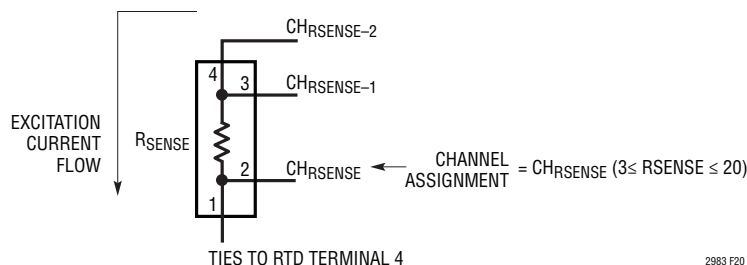

Figure 20. Sense Resistor with Kelvin Connections Channel Assignment Convention

APPLICATIONS INFORMATION

Figure 21 shows a typical temperature measurement system using a 4-wire RTD with a Kelvin connected R_{SENSE} . In this example, the 4-wire RTD's terminals tie to CH₁₇, CH₁₆, CH₁₅, and CH₆. The sense resistor ties to CH₆, CH₅, and CH₄ and excitation current is applied to CH₄ and CH₁₇. The sense resistor's nominal value is 1k Ω in order to accommodate a 1mA excitation current. The sense resistor and RTD connect together at CH₆. This topology supports both rotated, shared and standard 4-wire RTD topologies. If rotated or shared

configuration are not used then terminal 1 of the RTD is tied to ground instead of CH₁₇, freeing up one input channel. Channel assignment data is shown in Tables 48 and 49.

A conversion is initiated on CH₁₆ by writing 10010000 into memory location 0x000. Once the conversion is complete, the INTERRUPT pin goes HIGH and memory location 0x000 becomes 01010000 (see Table 6). The resulting temperature in $^{\circ}\text{C}$ can be read from memory locations 0x04C to 0x04F (corresponding to CH₁₆).

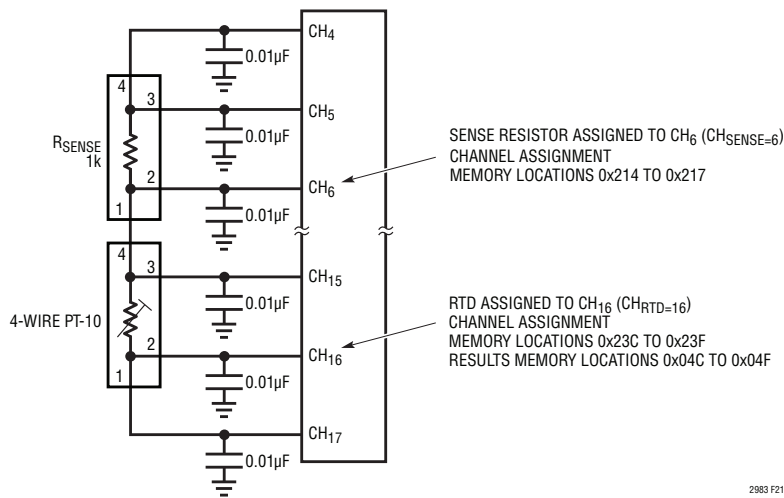

Figure 21. Sense Resistor with Kelvin Connections Example

Table 48. Channel Assignment Data for 4-Wire RTD with Kelvin Connected R_{SENSE} (PT-10, R_{SENSE} on CH₆, 4-Wire, Kelvin R_{SENSE} with Rotated 1mA Excitation Current, $\alpha = 0.003916$ Standard)

| CONFIGURATION FIELD | DESCRIPTION | # BITS | BINARY DATA | MEMORY ADDRESS 0x23C | MEMORY ADDRESS 0x23D | MEMORY ADDRESS 0x23E | MEMORY ADDRESS 0x23F |
|------------------------------------|--|--------|--------------|----------------------|----------------------|----------------------|-------------------------|
| (1) RTD TYPE | PT-10 | 5 | 01010 | 0 1 0 1 0 | | | |
| (2) Sense Resistor Channel Pointer | CH ₆ | 5 | 00110 | | 0 0 1 1 0 | | |
| (3) Sensor Configuration | 4-Wire Kelvin R_{SENSE} and Rotation | 4 | 1110 | | | 1 1 1 0 | |
| (4) Excitation Current | 1mA | 4 | 1000 | | | | 1 0 0 0 |
| (5) Standard | Japanese, $\alpha=0.003916$ | 2 | 10 | | | | 1 0 |
| (6) Custom RTD Data Pointer | Not Custom | 12 | 000000000000 | | | | 0 0 0 0 0 0 0 0 0 0 0 0 |

Table 49. Channel Assignment Data for Sense Resistor (Value = 1000 Ω)

| CONFIGURATION FIELD | DESCRIPTION | # BITS | BINARY DATA | MEMORY ADDRESS 0x214 | MEMORY ADDRESS 0x215 | MEMORY ADDRESS 0x216 | MEMORY ADDRESS 0x217 |
|--------------------------|----------------|--------|------------------------------|----------------------|---|----------------------|----------------------|
| (1) Sensor Type | Sense Resistor | 5 | 11101 | 1 1 1 0 1 | | | |
| (2) Sense Resistor Value | 1000 Ω | 27 | 0000000111110100000000000000 | | 0 0 0 0 0 0 0 0 1 1 1 1 1 0 1 0 0 0 0 0 0 0 0 0 0 0 0 | | |

APPLICATIONS INFORMATION

THERMISTOR MEASUREMENTS

Channel Assignment – Thermistor

For each thermistor tied to the LTC2983, a 32-bit channel assignment word is programmed into a memory location corresponding to the channel the sensor is tied to (see Table 50). This data includes (1) thermistor type, (2) sense resistor channel pointer, (3) sensor configuration, (4) excitation current, (5) Steinhart-Hart address pointer or custom table address pointer.

(1) Thermistor Type

The thermistor type is determined by the first five input bits (B31 to B27) as shown in Table 51. Linearization coefficients based on Steinhart-Hart equation for commonly used Thermistor types 44004/44033, 44005/44030, 44006/44031, 44007/44034, 44008/44032 and YSI-400 are built into the device. If other custom thermistors are used, Thermistor Custom Steinhart-Hart or Thermistor Custom Table (temperature vs resistance) can be selected. In this case, user specific data can be stored in the on-chip RAM starting at the address defined in Thermistor Custom Steinhart-Hart or Thermistor Custom Table address pointers.

Table 50. Thermistor Channel Assignment Word

| | (1) THERMISTOR TYPE | | | | | (2) SENSE RESISTOR CHANNEL POINTER | | | | | (3) SENSOR CONFIGURATION | | | (4) EXCITATION CURRENT | | | | (5) CUSTOM THERMISTOR DATA POINTER | | | | | | | | | | | | | | | | |
|-------------------|---------------------|----|----|----|----|--|----|----|----|----|--------------------------|----|----|------------------------|----|----|----|------------------------------------|----|----|----|-------------------|---|---|----------------------|---|---|---|---|-------------------------|---|---|--|--|
| | TABLE 51 | | | | | TABLE 27 | | | | | TABLE 52 | | | TABLE 53 | | | | TABLES 76, 77, 78, 80, 81 | | | | | | | | | | | | | | | | |
| Measurement Class | 31 | 30 | 29 | 28 | 27 | 26 | 25 | 24 | 23 | 22 | 21 | 20 | 19 | 18 | 17 | 16 | 15 | 14 | 13 | 12 | 11 | 10 | 9 | 8 | 7 | 6 | 5 | 4 | 3 | 2 | 1 | 0 | | |
| Thermistor | Type = 19 to 27 | | | | | R _{SENSE} Channel Pointer [4:0] | | | | | SGL = 1 DIFF = 0 | | | Excitation Mode | | | | Excitation Current [3:0] | | | | Not Used 0 0 0 | | | Custom Address [5:0] | | | | | Custom Length – 1 [5:0] | | | | |

Table 51. Thermistor Type: $1/T = A + B \cdot \ln(R) + C \cdot \ln(R)^2 + D \cdot \ln(R)^3 + E \cdot \ln(R)^4 + F \cdot \ln(R)^5$

| B31 | B30 | B29 | B28 | B27 | THERMISTOR TYPE | A | B | C | D | E | F |
|-----|-----|-----|-----|-----|---|-------------|-------------|------------|-------------|------------|------------|
| 1 | 0 | 0 | 1 | 1 | Thermistor 44004/44033 2.252kΩ at 25°C | 1.46800E-03 | 2.38300E-04 | 0 | 1.00700E-07 | 0 | 0 |
| 1 | 0 | 1 | 0 | 0 | Thermistor 44005/44030 3kΩ at 25°C | 1.40300E-03 | 2.37300E-04 | 0 | 9.82700E-08 | 0 | 0 |
| 1 | 0 | 1 | 0 | 1 | Thermistor 44007/44034 5kΩ at 25°C | 1.28500E-03 | 2.36200E-04 | 0 | 9.28500E-08 | 0 | 0 |
| 1 | 0 | 1 | 1 | 0 | Thermistor 44006/44031 10kΩ at 25°C | 1.03200E-03 | 2.38700E-04 | 0 | 1.58000E-07 | 0 | 0 |
| 1 | 0 | 1 | 1 | 1 | Thermistor 44008/44032 30kΩ at 25°C | 9.37600E-04 | 2.20800E-04 | 0 | 1.27600E-07 | 0 | 0 |
| 1 | 1 | 0 | 0 | 0 | Thermistor YSI-400 2.252kΩ at 25°C | 1.47134E-03 | 2.37624E-04 | 0 | 1.05034E-07 | 0 | 0 |
| 1 | 1 | 0 | 0 | 1 | Spectrum 1003k 1kΩ at 25°C | 1.445904E-3 | 2.68399E-04 | 0 | 1.64066E-07 | 0 | 0 |
| 1 | 1 | 0 | 1 | 0 | Thermistor Custom Steinhart-Hart | user input | user input | user input | user input | user input | user input |
| 1 | 1 | 0 | 1 | 1 | Thermistor Custom Table | not used | not used | not used | not used | not used | not used |

APPLICATIONS INFORMATION

(2) Sense Resistor Channel Pointer

Thermistor measurements are performed ratiometrically relative to a known R_{SENSE} resistor. The sense resistor channel pointer field indicates the differential channel the sense resistor is tied to for the current thermistor (see Table 27).

(3) Sensor Configuration

The sensor configuration field is used to define various thermistor properties. Configuration bit B21 is set high for single-ended (measurement relative to COM) and low for differential (see Table 52).

The next sensor configuration bits (B19 and B20) determine the excitation current mode. These bits are used to enable R_{SENSE} sharing, where one sense resistor is used for multiple thermistors. In this case, the thermistor ground connection is internal and each thermistor points to the same R_{SENSE} channel.

Bits B19 and B20 are also used to enable excitation current rotation to automatically remove parasitic thermocouple effects. Parasitic thermocouple effects may arise from the physical connected between the thermistor and the measurement instrument. This mode is available for differential thermistor configurations using internal current source excitation.

Table 52. Sensor Configuration Data

| (3) SENSOR CONFIGURATION | | | SINGLE-ENDED/ DIFFERENTIAL | SHARE R_{SENSE} | ROTATE |
|--------------------------|-----------------|-----|-------------------------------|----------------------|--------|
| SGL | EXCITATION MODE | | | | |
| B21 | B20 | B19 | | | |
| 0 | 0 | 0 | Differential | No | No |
| 0 | 0 | 1 | Differential | Yes | Yes |
| 0 | 1 | 0 | Differential | Yes | No |
| 0 | 1 | 1 | | Reserved | |
| 1 | 0 | 0 | Single-Ended | No | No |
| 1 | 0 | 1 | | Reserved | |
| 1 | 1 | 0 | | Reserved | |
| 1 | 1 | 1 | | Reserved | |

(4) Excitation Current

The next field in the channel assignment word (B18 to B15) controls the magnitude of the excitation current applied to the thermistor (see Table 53). In order to prevent hard or soft faults, select a current such that the maximum voltage drop across the sensor or sense resistor is nominally 1.0V. The LTC2983 has no special requirements related to the ratio between the voltage drop across the sense resistor and the sensor. Consequently, it is possible to have a sense resistor several orders of magnitude smaller than the maximum sensor value. For optimal performance over the full thermistor temperature range, auto ranged current can be selected. In this case, the LTC2983 conversion is performed in three cycles (instead of the standard two cycles) (see Table 64). The first cycle determines the optimal excitation current for the sensor resistance value and R_{SENSE} value. The following two cycles use that current to measure the thermistor temperature.

Table 53. Excitation Current for Thermistors

| (4) EXCITATION CURRENT | | | | CURRENT |
|------------------------|-----|-----|-----|-------------|
| B18 | B17 | B16 | B15 | |
| 0 | 0 | 0 | 0 | Reserved |
| 0 | 0 | 0 | 1 | 250nA |
| 0 | 0 | 1 | 0 | 500nA |
| 0 | 0 | 1 | 1 | 1 μ A |
| 0 | 1 | 0 | 0 | 5 μ A |
| 0 | 1 | 0 | 1 | 10 μ A |
| 0 | 1 | 1 | 0 | 25 μ A |
| 0 | 1 | 1 | 1 | 50 μ A |
| 1 | 0 | 0 | 0 | 100 μ A |
| 1 | 0 | 0 | 1 | 250 μ A |
| 1 | 0 | 1 | 0 | 500 μ A |
| 1 | 0 | 1 | 1 | 1mA |
| 1 | 1 | 0 | 0 | Auto Range* |
| 1 | 1 | 0 | 1 | Invalid |
| 1 | 1 | 1 | 0 | Invalid |
| 1 | 1 | 1 | 1 | External |

*Auto Range not allowed for custom sensors

(5) Steinhart-Hart Address/Custom Table Address

See Custom Thermistors section near the end of this data sheet for more information.

APPLICATIONS INFORMATION

Fault Reporting – Thermistor

Each sensor type has unique fault reporting mechanism indicated in the upper byte of the data output word. Table 54 shows faults reported during the measurement of thermistors.

Bit D31 indicates the thermistor or R_{SENSE} is open, shorted, or not plugged in. This is a hard fault and -999°C is reported. Bit D30 indicates a bad ADC reading. This could be a result of either a broken (open) sensor or an excessive noise event (ESD or static discharge into the sensor path).

This is a hard error and -999°C is output. In the case of an excessive noise event, the device should recover and the following conversions will be valid if the noise event was a random infrequent event. Bits D29 and D28 are not used for thermistors. Bits D27 and D26 indicate the reading is over or under temperature limits (see Table 55). The calculated temperature is reported, but the accuracy may be compromised. Bit D25 indicates the absolute voltage measured by the ADC is beyond its normal operating range. If a thermistor is used as the cold junction element, any hard or soft error is flagged in the thermocouple result.

Table 54. Thermistor Fault Reporting

| BIT | FAULT | ERROR TYPE | DESCRIPTION | OUTPUT RESULT |
|-----|--------------------------|------------|--|------------------------|
| D31 | Sensor Hard Fault | Hard | Open or Short Thermistor or R_{SENSE} | -999°C |
| D30 | Hard ADC-Out-of-Range | Hard | Bad ADC Reading (Could Be Large External Noise Event) | -999°C |
| D29 | Not Used for Thermistors | N/A | Always 0 | Valid Reading |
| D28 | Not Used for Thermistors | N/A | Always 0 | Valid Reading |
| D27 | Sensor Over Range* | Soft | $T > \text{High Temp Limit}$ | Suspect Reading |
| D26 | Sensor Under Range* | Soft | $T < \text{Low Temp Limit}$ | Suspect Reading |
| D25 | ADC Out-of-Range | Soft | ADC Absolute Input Voltage Is Beyond $\pm 1.125 \cdot V_{REF}/2$ | Suspect Reading |
| D24 | Valid | N/A | Result Valid (Should Be 1) Discard Results if 0 | Valid Reading |

*Do not apply to custom Steinhart-Hart sensor type.

APPLICATIONS INFORMATION

Table 55. Thermistor Temperature/Resistance Range

| THERMISTOR TYPE | MIN (Ω) | MAX (Ω) | LOW Temp Limit ($^{\circ}\text{C}$) | HIGH Temp Limit ($^{\circ}\text{C}$) |
|---|--------------------|------------------|---------------------------------------|--|
| Thermistor 44004/44033 2.252k Ω at 25 $^{\circ}\text{C}$ | 41.9 | 75.79k | -40 | 150 |
| Thermistor 44005/44030 3k Ω at 25 $^{\circ}\text{C}$ | 55.6 | 101.0k | -40 | 150 |
| Thermistor 44007/44034 5k Ω at 25 $^{\circ}\text{C}$ | 92.7 | 168.3k | -40 | 150 |
| Thermistor 44006/44031 10k Ω at 25 $^{\circ}\text{C}$ | 237.0 | 239.8k | -40 | 150 |
| Thermistor 44008/44032 30k Ω at 25 $^{\circ}\text{C}$ | 550.2 | 884.6k | -40 | 150 |
| Thermistor YSI 400 2.252k Ω at 25 $^{\circ}\text{C}$ | 6.4 | 1.66M | -80 | 250 |
| Spectrum 1003K 1k Ω at 25 $^{\circ}\text{C}$ | 51.1 | 39.51k | -50 | 125 |
| Thermistor Custom Steinhart-Hart | N/A | N/A | N/A | N/A |
| Thermistor Custom Table | Second Table Entry | Last Table Entry | | |

Example: Single-Ended Thermistor

The simplest thermistor configuration is the single-ended configuration. Thermistors using this configuration share a common ground (COM) between all sensors and are each tied to a unique sense resistor (R_{SENSE} sharing is not allowed for single-ended thermistors). Single-ended thermistors follow the convention shown in Figure 22. Terminal 1 ties to ground (COM) and terminal 2 ties to CH_{THERM} and the sense resistor. Channel assignment data (see Table 50) is mapped to memory locations corresponding to CH_{THERM} .

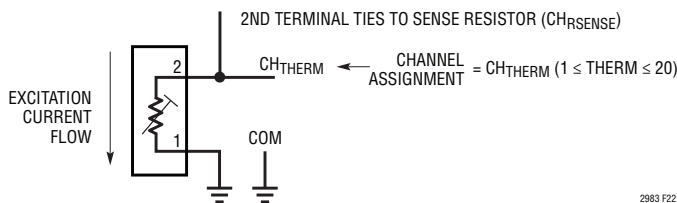

Figure 22. Single-Ended Thermistor Channel Assignment Convention

Sense resistor channel assignments follow the general convention shown in Figure 23. The sense resistor is tied between $\text{CH}_{\text{RSENSE}}$ and $\text{CH}_{\text{RSENSE}-1}$, where $\text{CH}_{\text{RSENSE}}$ is tied to the 2nd terminal of the thermistor. Channel assignment data (see Table 33) is mapped into the memory location corresponding to $\text{CH}_{\text{RSENSE}}$.

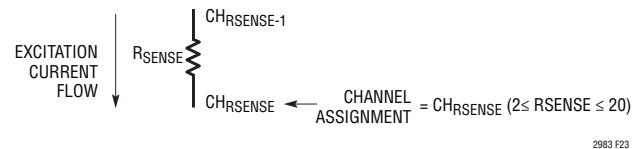

Figure 23. Sense Resistor Channel Assignment Convention

APPLICATIONS INFORMATION

Figure 24 shows a typical temperature measurement system using a single-ended thermistor. In this example a 10kΩ (44031 type) thermistor is tied to a 10.1kΩ sense resistor. The thermistor is assigned channel CH5 (memory locations 0x210 to 0x213) and the sense resistor to CH4 (memory locations 0x20C to 0x20F). Channel assignment data are shown in Tables 56 and 57.

A conversion is initiated on CH5 by writing 10000101 into memory location 0x000. Once the conversion is complete, the INTERRUPT pin goes HIGH and memory location 0x000 becomes 01000101. The resulting temperature in °C can be read from memory locations 0x020 to 0x023 (corresponding to CH5).

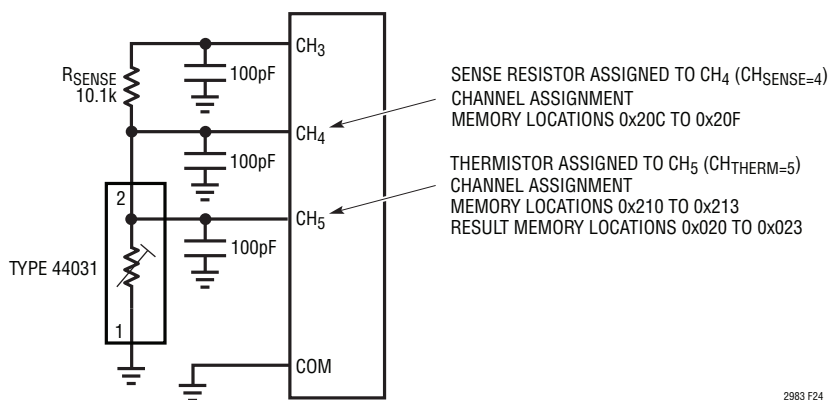

Figure 24. Single-Ended Thermistor Example

Table 56. Channel Assignment Data for Single-Ended Thermistor (44006/44031 10kΩ at 25°C Type Thermistor, Single-Ended Configuration, R_SENSE on CH4, 1μA Excitation Current)

| CONFIGURATION FIELD | DESCRIPTION | # BITS | BINARY DATA | MEMORY ADDRESS 0x210 | MEMORY ADDRESS 0x211 | MEMORY ADDRESS 0x212 | MEMORY ADDRESS 0x213 |
|------------------------------------|--------------------------|--------|--------------|----------------------|----------------------|-------------------------|----------------------|
| (1) Thermistor Type | 44006/44031 10kΩ at 25°C | 5 | 10110 | 1 0 1 1 0 | | | |
| (2) Sense Resistor Channel Pointer | CH4 | 5 | 00100 | | 0 0 1 0 0 | | |
| (3) Sensor Configuration | Single-Ended | 3 | 100 | | 1 0 0 | | |
| (4) Excitation Current | 1μA | 4 | 0011 | | 0 0 1 1 | | |
| Not Used | Set These Bits to 0 | 3 | 000 | | | 0 0 0 | |
| (5) Custom RTD Data Pointer | Not Custom | 12 | 000000000000 | | | 0 0 0 0 0 0 0 0 0 0 0 0 | |

Table 57. Channel Assignment Data for Sense Resistor (Value = 10.1kΩ)

| CONFIGURATION FIELD | DESCRIPTION | # BITS | BINARY DATA | MEMORY ADDRESS 0x20C | MEMORY ADDRESS 0x20D | MEMORY ADDRESS 0x20E | MEMORY ADDRESS 0x20F |
|--------------------------|----------------|--------|----------------------------|----------------------|---|----------------------|----------------------|
| (1) Sensor Type | Sense Resistor | 5 | 11101 | 1 1 1 0 1 | | | |
| (2) Sense Resistor Value | 10.1kΩ | 27 | 00010011101110100000000000 | | 0 0 0 1 0 0 1 1 1 0 1 1 1 0 1 0 0 0 0 0 0 0 0 0 0 0 | | |

2983fa

APPLICATIONS INFORMATION

Example: Differential Thermistor

The differential thermistor configuration allows separate ground sensing for each sensor. In this standard differential configuration, one sense resistor is used for each thermistor. Differential thermistors follow the convention shown in Figure 25. Terminal 1 ties to CH_{THERM} and is shorted to ground and terminal 2 ties $CH_{THERM-1}$ to and the sense resistor. Channel assignment data (see Table 50) is mapped to memory locations corresponding to CH_{THERM} .

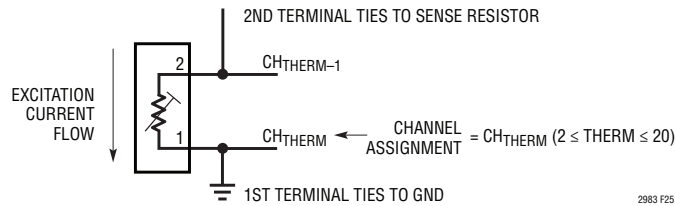

Figure 25. Differential Thermistor Channel Assignment Convention

Sense resistor channel assignments follow the general convention shown in Figure 26. The sense resistor is tied between CH_{RSENSE} and $CH_{RSENSE-1}$, where CH_{RSENSE} is tied to the 2nd terminal of the thermistor. Channel assignment data (see Table 33) is mapped into a memory location corresponding to CH_{RSENSE} .

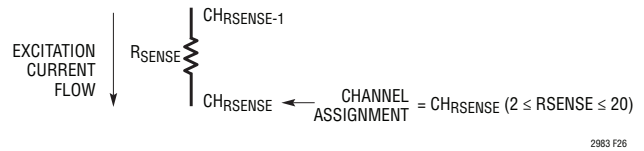

Figure 26. Sense Resistor Channel Assignment Convention

APPLICATIONS INFORMATION

Figure 27 shows a typical temperature measurement system using a differential thermistor. In this example a 30kΩ (44032 type) thermistor is tied to a 9.99kΩ sense resistor. The thermistor is assigned channel CH13 (memory locations 0x230 to 0x233) and the sense resistor to CH11 (memory locations 0x228 to 0x22B). Channel assignment data is shown in Tables 58 and 59).

A conversion is initiated on CH₁₃ by writing 10001101 into memory location 0x000. Once the conversion is complete, the INTERRUPT pin goes HIGH and memory location 0x000 becomes 01001101. The resulting temperature in °C can be read from memory locations 0x040 to 0x043 (Corresponding to CH₁₃).

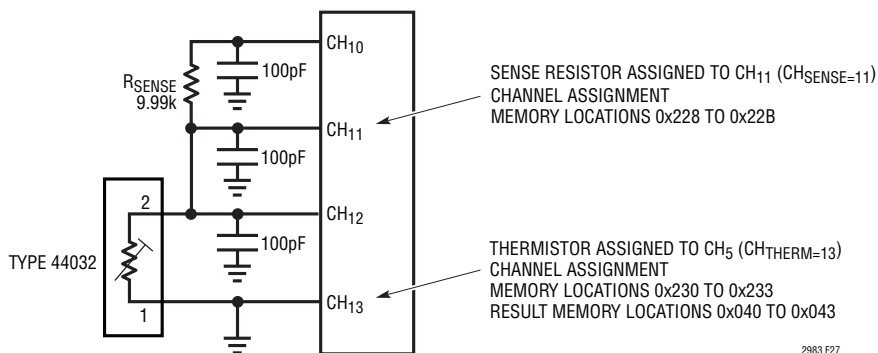

Figure 27. Differential Thermistor Example

Table 58. Channel Assignment Data for Differential Thermistor (44008/44032 30kΩ at 25°C Type Thermistor, Differential Configuration, R_{SENSE} on CH₁₁, Auto Range Excitation)

| CONFIGURATION FIELD | DESCRIPTION | # BITS | BINARY DATA | MEMORY ADDRESS 0x230 | MEMORY ADDRESS 0x231 | MEMORY ADDRESS 0x232 | MEMORY ADDRESS 0x233 |
|------------------------------------|-----------------------------------|--------|--------------|----------------------|----------------------|----------------------|-------------------------|
| (1) Thermistor Type | 44008/44032 30kΩ at 25°C | 5 | 10111 | 1 0 1 1 1 | | | |
| (2) Sense Resistor Channel Pointer | CH ₁₁ | 5 | 01011 | | 0 1 0 1 1 | | |
| (3) Sensor Configuration | Differential, No Share, No Rotate | 3 | 000 | | 0 0 0 | | |
| (4) Excitation Current | Auto Range | 4 | 1100 | | 1 1 0 0 | | |
| Not Used | Set These Bits to 0 | 2 | 000 | | | 0 0 0 | |
| (5) Custom RTD Data Pointer | Not Custom | 12 | 000000000000 | | | | 0 0 0 0 0 0 0 0 0 0 0 0 |

Table 59. Channel Assignment Data for Sense Resistor (Value = 9.99kΩ)

| CONFIGURATION FIELD | DESCRIPTION | # BITS | BINARY DATA | MEMORY ADDRESS 0x228 | MEMORY ADDRESS 0x229 | MEMORY ADDRESS 0x22A | MEMORY ADDRESS 0x22B |
|--------------------------|----------------|--------|----------------------------|----------------------|---|----------------------|----------------------|
| (1) Sensor Type | Sense Resistor | 5 | 11101 | 1 1 1 0 1 | | | |
| (2) Sense Resistor Value | 9.99kΩ | 27 | 00010011100000110000000000 | | 0 0 0 1 0 0 1 1 1 0 0 0 0 0 0 1 1 0 0 0 0 0 0 0 0 0 0 | | |

2983fa

APPLICATIONS INFORMATION

Example: Shared/Rotated Differential Thermistor

The differential thermistor configuration allows separate internal ground sensing for each sensor. In this configuration, one sense resistor can be used for multiple thermistors. Differential thermistors follow the convention shown in Figure 28. Terminal 1 ties to CH_{THERM} and terminal 2 ties to $CH_{THERM-1}$ and the sense resistor. Channel assignment data (see Table 50) is mapped to memory locations corresponding to CH_{THERM} .

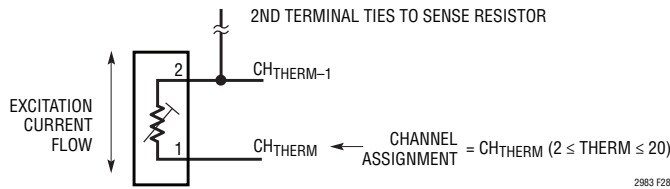

Figure 28. Thermistor with Shared R_{SENSE} Channel Assignment Convention

Sense resistor channel assignments follow the general convention shown in Figure 29. The sense resistor is tied between CH_{RSENSE} and $CH_{RSENSE-1}$, where CH_{SENSE} is tied to the 2nd terminal of the thermistor. Channel assignment data (see Table 33) is mapped into a memory location corresponding to CH_{THERM} .

Figure 30 shows a typical temperature measurement system using a shared sense resistor and one rotated/one non-rotated differential thermistors. In this example

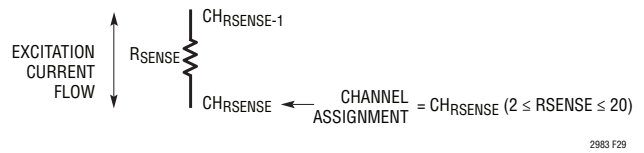

Figure 29. Sense Resistor Channel Assignment Convention for Thermistors

APPLICATIONS INFORMATION

a 30kΩ (44032 Type) thermistor is tied to a 10.0kΩ sense resistor and configured as rotated/shared. The second thermistor a 2.25kΩ (44004 Type) is configured as a non-rotated/shared. Channel assignment data are shown in Tables 60 to 62.

A conversion is initiated on CH₁₈ by writing 10010010 into memory location 0x000. Once the conversion is complete, the INTERRUPT pin goes HIGH and memory location 0x000 becomes 01010010. The resulting temperature in °C can be read from memory locations 0x054 to 0x057 (corresponding to CH₁₆). A conversion can be initiated and read from CH₂₀ in a similar fashion.

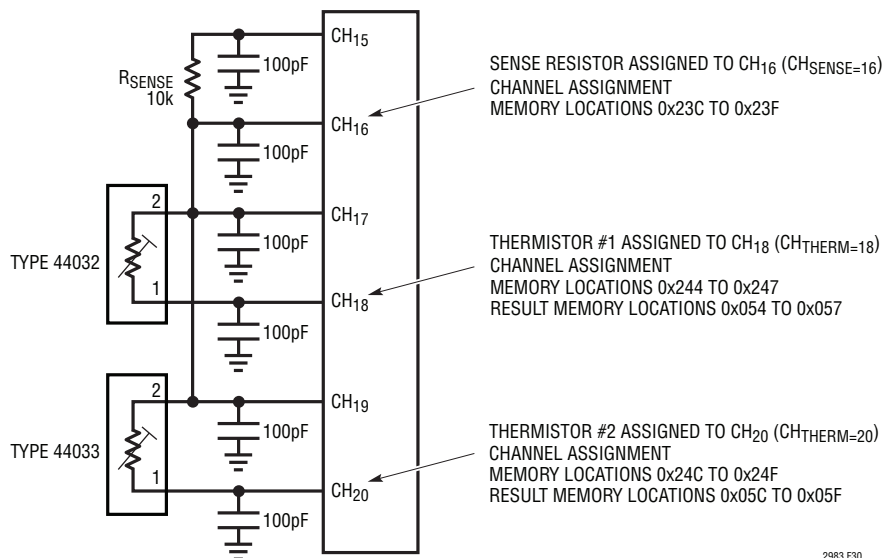

Figure 30. Rotated and Shared Thermistor Example

Table 60. Channel Assignment Data Differential Thermistor (44008/44032 30kΩ at 25°C Type Thermistor, Differential Configuration with Sharing and Rotation, R_{SENSE} on CH₁₆, 250nA Excitation Current)

| CONFIGURATION FIELD | DESCRIPTION | # BITS | BINARY DATA | MEMORY ADDRESS 0x244 | MEMORY ADDRESS 0x245 | MEMORY ADDRESS 0x246 | MEMORY ADDRESS 0x247 |
|------------------------------------|---------------------------------|--------|--------------|----------------------|----------------------|----------------------|-------------------------|
| (1) Thermistor Type | 44008/44032 30kΩ at 25°C | 5 | 10111 | 1 0 1 1 1 | | | |
| (2) Sense Resistor Channel Pointer | CH ₁₆ | 5 | 10000 | | 1 0 0 0 0 | | |
| (3) Sensor Configuration | Differential, Rotate and Shared | 3 | 001 | | 0 0 1 | | |
| (4) Excitation Current | 250nA Excitation Current | 4 | 0001 | | 0 0 0 1 | | |
| Not Used | Set These Bits to 0 | 3 | 000 | | | 0 0 0 | |
| (5) Custom RTD Data Pointer | Not Custom | 12 | 000000000000 | | | | 0 0 0 0 0 0 0 0 0 0 0 0 |

APPLICATIONS INFORMATION

Table 61. Channel Assignment Data Differential Thermistor (44004/44033 2.252kΩ at 25°C Type Thermistor, Differential Configuration with Sharing and No Rotation, R_{SENSE} on CH₁₆, 10μA Excitation Current)

| Configuration Field | Description | # Bits | Binary Data | MEMORY ADDRESS 0x24C | MEMORY ADDRESS 0x24D | MEMORY ADDRESS 0x24E | MEMORY ADDRESS 0x24F |
|------------------------------------|------------------------------------|--------|--------------|----------------------|----------------------|----------------------|-------------------------|
| (1) Thermistor Type | 44004/44033 2.252kΩ at 25°C | 5 | 10011 | 1 0 0 1 1 | | | |
| (2) Sense Resistor Channel Pointer | CH ₁₆ | 5 | 10000 | | 1 0 0 0 0 | | |
| (3) Sensor Configuration | Differential, No Rotate and Shared | 3 | 010 | | | 0 1 0 | |
| (4) Excitation Current | 10μA Excitation Current | 4 | 0101 | | | 0 1 0 1 | |
| Not Used | Set These Bits to 0 | 3 | 000 | | | 0 0 0 | |
| (5) Custom RTD Data Pointer | Not Custom | 12 | 000000000000 | | | | 0 0 0 0 0 0 0 0 0 0 0 0 |

Table 62. Channel Assignment Data for Sense Resistor (Value = 10.0kΩ)

| Configuration Field | Description | # Bits | Binary Data | MEMORY ADDRESS 0x23C | MEMORY ADDRESS 0x23D | MEMORY ADDRESS 0x23E | MEMORY ADDRESS 0x23F |
|--------------------------|----------------|--------|------------------------------|----------------------|---|----------------------|----------------------|
| (1) Sensor Type | Sense Resistor | 5 | 11101 | 1 1 1 0 1 | | | |
| (2) Sense Resistor Value | 10.0kΩ | 27 | 0001001110001000000000000000 | | 0 0 0 1 0 0 1 1 1 0 0 0 1 0 0 0 0 0 0 0 0 0 0 0 0 0 0 | | |

APPLICATIONS INFORMATION

Typical Application Thermocouple Measurements

The LTC2983 includes 20 fully configurable analog input channels. Each input channel can be configured to accept any sensor type. Figure 31 shows a typical application digitizing multiple thermocouples. Each thermocouple requires a cold junction sensor and each cold junction sensor can be shared amongst multiple thermocouples.

For example, the thermocouple tied to CH1 can use the diode tied to CH2 as a cold junction sensor. However, any thermocouple (CH1, CH3, CH5, CH6, CH9, CH10, or CH16) can use any diode (CH2, CH4, or CH7), RTD (CH13, CH14), or Thermistor (CH19, CH20) as its cold junction compensation. The LTC2983 simultaneously measures both the thermocouple and cold junction sensor and outputs the results in °C or °F.

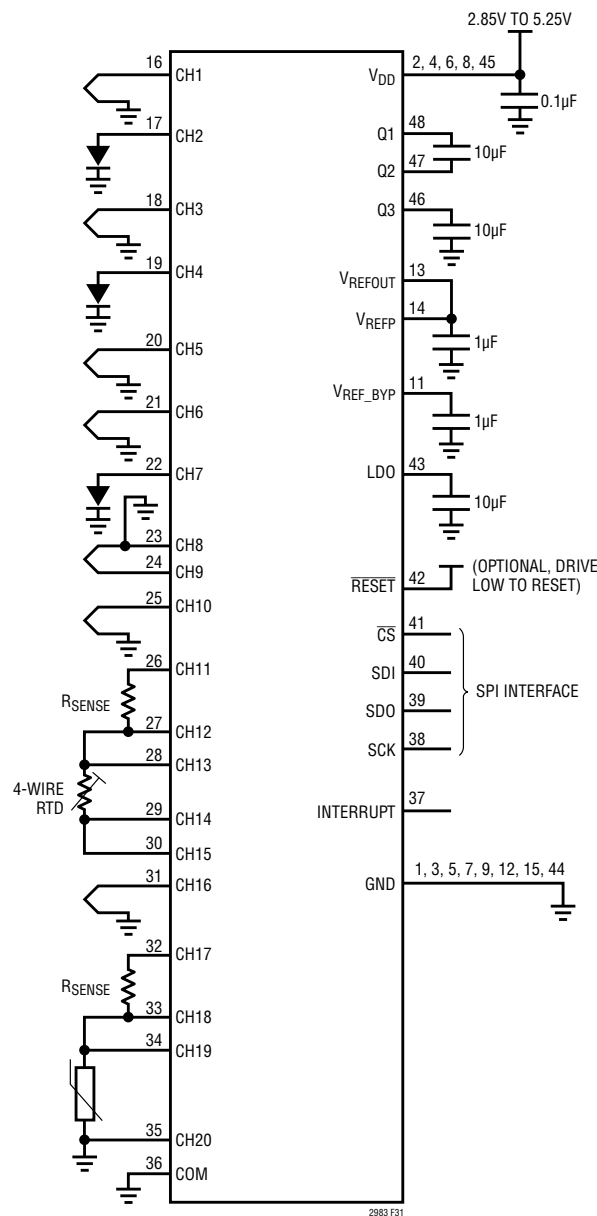

Figure 31. Typical Thermocouple Application

APPLICATIONS INFORMATION

Typical Application RTD and Thermistor Measurements

The LTC2983 includes 20 fully configurable analog input channels. Each input channel can be configured to accept any sensor type. Figure 32 shows a typical application digitizing multiple RTDs and thermistors. Each RTD/thermistor requires a sense resistor which can be shared with multiple sensors. RTDs can be configured as 2, 3, or 4-wire topologies. For example, a single sense resistor

(CH1, CH2) is shared between a 4-wire RTD (CH4, CH3), a 2-wire RTD (CH7, CH6), two 3-wire RTDs (CH9, CH8 and CH11, CH10) and a thermistor (CH13, CH12). This can be mixed with diode sensors (CH15) and thermocouples (CH14). Sense resistors (CH17, CH16) can also be dedicated to specific sensors, in this case a 4-wire RTD (CH19, CH18). Current is applied through both the sense resistor and RTD/Thermistor, the resulting voltages are simultaneously measured and the results are output in °C or °F.

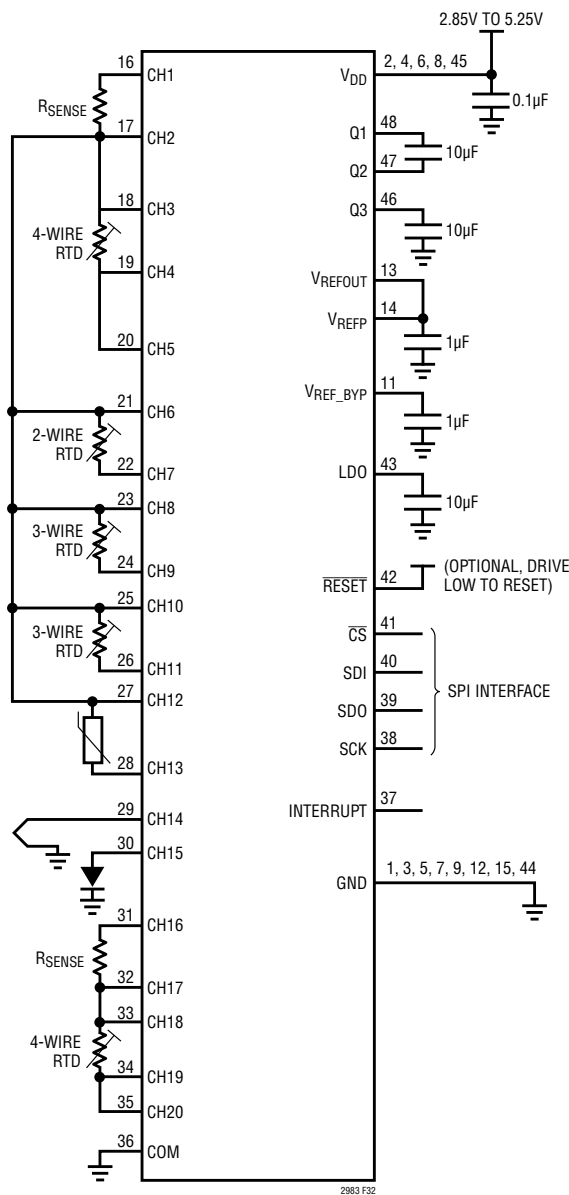

Figure 32. Typical RTD/Thermistor Application

SUPPLEMENTAL INFORMATION

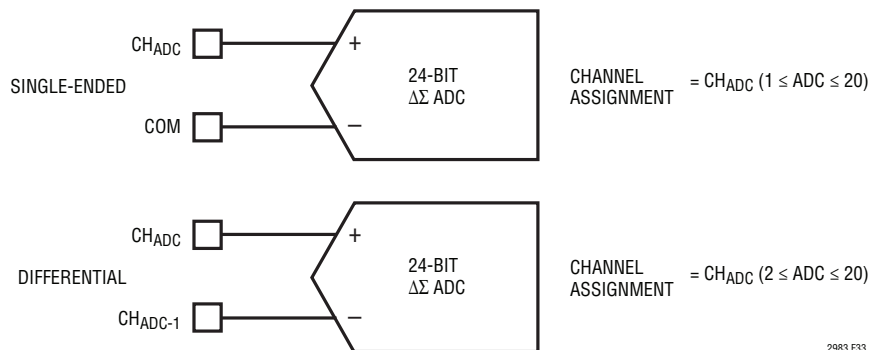

Figure 33. Direct ADC Channel Assignment Conventions

Direct ADC Measurements

In addition to measuring temperature sensors, the LTC2983 can perform direct voltage measurements. Any channel can be configured to perform direct single-ended or differential measurements. Direct ADC channel assignments follow the general convention shown in Figure 33. The 32-bit channel assignment word is programmed into a memory location corresponding to the input channel. The channel assignment word is 0xF000 0000 for differ-

ential readings and 0xF400 0000 for single-ended. The positive input channel ties to CH_{ADC} for both single-ended and differential modes. For single-ended measurements the ADC negative input is COM while for differential measurements it is CH_{ADC-1}. For single ended measurements, COM can be driven with any voltage above GND – 50mV and below V_{DD} – 0.3V.

The direct ADC results are available in memory at a location corresponding to the conversion channel.

Table 63. Direct ADC Output Format

| | START ADDRESS | | | | | | | | START ADDRESS + 1 | | | | | | | | START ADDRESS + 2 | | | | | | | | START ADDRESS + 3 (END ADDRESS) | | | | | | | |
|------------------------------------|---------------|------------|-----|-----|------------|------------|------------|----------------|--|-----|-----|-----|----------|-----|-----|-----|-------------------|-----|-----|-----|-----|-----|----|----|---------------------------------|----|----|----|----|----|----|----|
| | D31 | D30 | D29 | D28 | D27 | D26 | D25 | D24 | D23 | D22 | D21 | D20 | D19 | D18 | D17 | D16 | D15 | D14 | D13 | D12 | D11 | D10 | D9 | D8 | D7 | D6 | D5 | D4 | D3 | D2 | D1 | D0 |
| | Fault Data | | | | | | | | SIGN MSB | | | | | | | | LSB | | | | | | | | | | | | | | | |
| Volts | Range Hard | Range Hard | NA | NA | Soft Above | Soft Below | Soft Range | Valid Always 1 | ± 2V 1V 0.5V 0.25V ... | | | | | | | | | | | | | | | | | | | | | | | |
| | | | | | | | | | Integer | | | | Fraction | | | | | | | | | | | | | | | | | | | |
| >V _{REF} | 1 | 1 | 0 | 0 | 1 | 0 | 1 | | CLAMPED to Factory Programmed Value of V _{REF} | | | | | | | | | | | | | | | | | | | | | | | |
| 1.75 • V _{REF} /2 | 1 | 1 | 0 | 0 | 1 | 0 | 1 | 1 | 0 | 1 | 0 | 0 | 0 | 1 | 1 | 0 | 0 | 0 | 0 | 0 | 0 | 0 | 0 | 0 | 0 | 0 | 0 | 0 | 0 | 0 | 0 | |
| 1.125 • V _{REF} /2 | 0 | 0 | 0 | 0 | 1 | 0 | 1 | 1 | 0 | 0 | 1 | 0 | 1 | 1 | 0 | 1 | 0 | 0 | 0 | 0 | 0 | 0 | 0 | 0 | 0 | 0 | 0 | 0 | 0 | 0 | 0 | |
| V _{REF} /2 | 0 | 0 | 0 | 0 | 0 | 0 | 0 | 1 | 0 | 0 | 1 | 0 | 1 | 0 | 0 | 0 | 0 | 0 | 0 | 0 | 0 | 0 | 0 | 0 | 0 | 0 | 0 | 0 | 0 | 0 | 0 | |
| V _{REF} /2 ²² | 0 | 0 | 0 | 0 | 0 | 0 | 0 | 1 | 0 | 0 | 0 | 0 | 0 | 0 | 0 | 0 | 0 | 0 | 0 | 0 | 0 | 0 | 0 | 0 | 0 | 0 | 0 | 0 | 0 | 0 | 1 | |
| 0 | 0 | 0 | 0 | 0 | 0 | 0 | 0 | 1 | 0 | 0 | 0 | 0 | 0 | 0 | 0 | 0 | 0 | 0 | 0 | 0 | 0 | 0 | 0 | 0 | 0 | 0 | 0 | 0 | 0 | 0 | 0 | |
| -V _{REF} /2 ²² | 0 | 0 | 0 | 0 | 0 | 0 | 0 | 1 | 1 | 1 | 1 | 1 | 1 | 1 | 1 | 1 | 1 | 1 | 1 | 1 | 1 | 1 | 1 | 1 | 1 | 1 | 1 | 1 | 1 | 1 | | |
| -V _{REF} /2 | 0 | 0 | 0 | 0 | 0 | 0 | 0 | 1 | 1 | 1 | 0 | 1 | 1 | 0 | 0 | 0 | 0 | 0 | 0 | 0 | 0 | 0 | 0 | 0 | 0 | 0 | 0 | 0 | 0 | 0 | 0 | |
| -1.125 • V _{REF} | 0 | 0 | 0 | 0 | 0 | 1 | 1 | 1 | 1 | 1 | 0 | 1 | 0 | 0 | 1 | 1 | 0 | 0 | 0 | 0 | 0 | 0 | 0 | 0 | 0 | 0 | 0 | 0 | 0 | 0 | 0 | |
| -1.75 • V _{REF} | 1 | 1 | 0 | 0 | 0 | 1 | 1 | 1 | 1 | 0 | 1 | 1 | 1 | 0 | 1 | 0 | 0 | 0 | 0 | 0 | 0 | 0 | 0 | 0 | 0 | 0 | 0 | 0 | 0 | 0 | 0 | |
| < -V _{REF} | 1 | 1 | 0 | 0 | 0 | 1 | 1 | 1 | CLAMPED to Factory Programmed Value of -V _{REF} | | | | | | | | | | | | | | | | | | | | | | | |

2983fa

SUPPLEMENTAL INFORMATION

The data is represented as a 32-bit word (see Table 63) where the eight most significant bits are fault bits and the bottom 24 are the ADC reading in volts. For direct ADC readings hard fault errors do not clamp the digital output. Readings beyond $\pm 1.125 \cdot V_{REF}/2$ exceed the normal accuracy range of the LTC2983 and flag a soft error; these results should be discarded. Readings beyond $\pm 1.75 \cdot$

$V_{REF}/2$ exceed the usable range of the LTC2983; these result in a hard fault and should be discarded.

Figures 34 to 36 show typical integral nonlinearity variation at various supply voltages and temperatures for a differential input voltage ($\pm V_{REF}/2$) and $V_{REF}/2$ common mode input voltage.

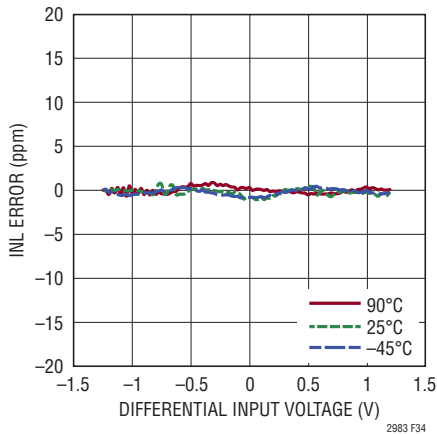

Figure 34. Integral Nonlinearity as a Function of Temperature at $V_{DD} = 5.25V$

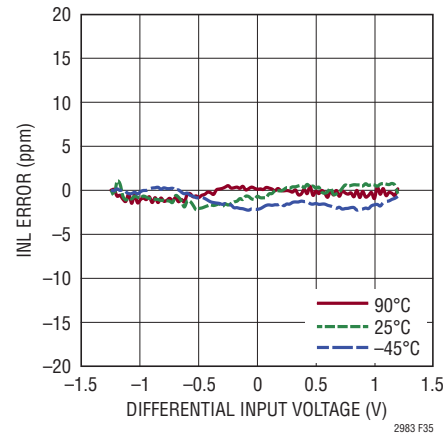

Figure 35. Integral Nonlinearity as a Function of Temperature at $V_{DD} = 3.3V$

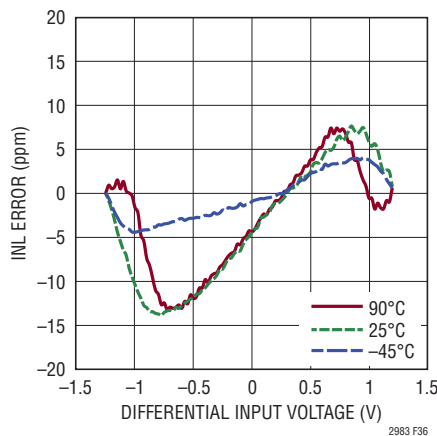

Figure 36. Integral Nonlinearity as a Function of Temperature at $V_{DD} = 2.85V$

SUPPLEMENTAL INFORMATION

Fault Protection and Anti-Aliasing

The LTC2983 analog input channels draw a maximum of 1nA DC. As a result, it is possible to add anti-aliasing and fault protection circuitry directly to the input of the LTC2983. The most common input circuitry is a low pass filter with 1k to 10k resistance (limited by excitation current for RTDs and thermistors) and a capacitor with 100pF-0.1 μ F capacitance. This circuit can be placed directly between the thermocouples and 4-wire RTDs and the LTC2983. In the case of 3-wire RTDs, mismatch errors between the protection resistors can degrade the performance. Thermistors requiring input protection should be tied to the LTC2983 through a Kelvin type connection in order to avoid errors due to the fault protection resistors.

2- and 3-Cycle Conversion Modes

The LTC2983 performs multiple internal conversions in order to determine the sensor temperature. Normally, two internal conversion cycles are required for each temperature result providing a maximum output time of 167.2ms. The LTC2983 uses these two cycles to automatically remove offset/offset drift errors, reduce 1/f noise, auto-calibrate matched internal current sources, and provide simultaneous 50/60Hz noise rejection.

In addition to performing two conversion cycles per result, the LTC2983 also offers several unique features by utilizing a 3rd conversion cycle. In this case, the maximum output time is 251ms and all the benefits of the 2-cycle modes are present (see Table 64).

One feature utilizing the three conversion cycle mode is the internal open circuit detect mode. Typically, thermocouple open circuit detection is performed by adding a high resistance pull-up between the thermocouple and V_{DD} . This method can be used with the LTC2983 while operating in the two conversion cycle mode (OC=0). This external pull-up can interact with the input protection circuitry and lead to temperature measurement errors and increased noise. These problems are eliminated by selecting the internal open circuit detection mode (OC=1). In this case, a current is pulsed for 8ms and allowed to settle during one conversion cycle. This is followed by the normal two

conversion cycle measurement of the thermocouple. If the thermocouple is broken, the current pulse will result in an open circuit fault.

A second feature taking advantage of the 3rd conversion cycle is thermistor excitation current auto ranging. Since a thermistor's resistance varies many orders of magnitude, the performance in the low resistance regions are compromised by the small currents required by the high resistance regions of operation. The auto ranging mode applies a test current during the first conversion cycle in order to determine the optimum current for the resistance state of the thermistor. It then uses that current to perform the thermistor measurement using the normal 2-cycle measurement. If a 3-cycle thermistor measurement is used as the cold junction sensor for a 2-cycle thermocouple measurement, the thermocouple conversion result is ready after three cycles.

A third feature requiring a 3rd conversion cycle is the three current diode measurement. In this mode, three ratioed currents are applied to the external diode in order to cancel parasitic lead resistance effects. This is useful in applications where the diode is remotely located and significant, unknown parasitic lead resistance requires cancellation. If a 3-cycle diode or thermistor measurement is used as the cold junction sensor for a 2-cycle thermocouple measurement, the thermocouple conversion result is ready after three cycles.

Table 64. 2- and 3-Cycles Conversion Modes

| TYPE OF SENSOR | CONFIGURATION | NUMBER OF CONVERSION CYCLES | MAXIMUM OUTPUT TIME |
|----------------|-------------------------------|-----------------------------|---------------------|
| Thermocouple | OC = 0 | 2 | 167.2ms |
| RTD | All | 2 | 167.2ms |
| Thermistor | Non-Autorange Current | 2 | 167.2ms |
| Diode | Two Readings | 2 | 167.2ms |
| Thermocouple | OC = 1 | 3 | 251ms |
| Thermocouple | OC = 0, 3-Cycle Cold Junction | 3 | 251ms |
| Thermistor | Autorange Current | 3 | 251ms |
| Diode | Three Readings | 3 | 251ms |

SUPPLEMENTAL INFORMATION

Running Conversions Consecutively on Multiple Channels

Generally, during the Initiate Conversion state, a conversion measurement is started on a single input channel determined by the channel number (bits B[4:0] = 00001 to 10100) written into memory location 0x000. Multiple consecutive conversions can be initiated by writing bits B[4:0]=00000 into memory location 0. Conversions will be initiated on each channel selected in the mask register (see Table 65).

For example, using the mask data shown in Table 66, after 1000000 is written into memory location 0, conversions are initiated consecutively on CH20, CH19, CH16, and CH1. Once the conversions begin, the INTERRUPT pin goes LOW and remains LOW until all conversions are complete. If the mask register is set for a channel that has no assignment data, that conversion step is skipped. All the results are stored in the conversion result memory locations and can be read at the conclusion of the measurement cycle.

Entering/Exiting Sleep Mode

The LTC2983 can be placed into sleep mode by writing 0x97 to memory location 0x000. On the rising edge of \overline{CS} following the memory write (see Figure 2) the device enters the low power sleep state. It remains in this state until \overline{CS} is brought low or \overline{RESET} is asserted. Once one of these two signals is asserted, the LTC2983 begins its start-up cycle as described in State 1: Start-Up section of this data sheet.

MUX Configuration Delay

The LTC2983 performs 2 or 3 internal conversion cycles per temperature result. Each conversion cycle is performed with different excitation and input multiplexer configurations. Prior to each conversion, these excitation circuits and input switch configurations are changed and an internal 1ms (typical) delay ensures settling prior to the conversion cycle in most cases.

Table 65. Multiple Conversion Mask Register

| MEMORY LOCATION | B7 | B6 | B5 | B4 | B3 | B2 | B1 | B0 |
|-----------------|------|----------|------|------|------|------|------|------|
| 0x0F4 | | Reserved | | | | | | |
| 0x0F5 | | | | | CH20 | CH19 | CH18 | CH17 |
| 0x0F6 | CH16 | CH15 | CH14 | CH13 | CH12 | CH11 | CH10 | CH9 |
| 0x0F7 | CH8 | CH7 | CH6 | CH5 | CH4 | CH3 | CH2 | CH1 |

Table 66. Example Mask Register Select CH20, CH19, CH16, and CH1

| MEMORY LOCATION | B7 | B6 | B5 | B4 | B3 | B2 | B1 | B0 |
|-----------------|----|----------|----|----|----|----|----|----|
| 0x0F4 | | Reserved | | | | | | |
| 0x0F5 | | | | | 1 | 1 | 0 | 0 |
| 0x0F6 | 1 | 0 | 0 | 0 | 0 | 0 | 0 | 0 |
| 0x0F7 | 0 | 0 | 0 | 0 | 0 | 0 | 0 | 1 |

SUPPLEMENTAL INFORMATION

If excessive RC time constants are present in external sensor circuits (large bypass capacitors used for thermistors or RTDs) it is possible to increase the settling time between current source excitation and MUX switching. The extra delay is determined by the value written into the MUX configuration delay register (memory location 0x0FF). The value written into this memory location is multiplied by 100µs; therefore the maximum extra MUX delay is 25.5ms (i.e. 0xFF = 255 • 100µs).

Global Configuration Register

The LTC2983 includes a global configuration register (memory location 0x0F0, see Figure 37). This register is used to set the notch frequency of the digital filter and temperature results format (°C or °F). The default setting is simultaneous 50/60Hz rejection (75dB rejection with 1ms MUX delay). If higher 60Hz rejection is required (120dB rejection), write 0x01 into memory location 0x0F0; if higher 50Hz rejection is required (120dB rejection) write 0x02 into memory location 0x0F0.

The default temperature units reported by the LTC2983 are °C. The reported temperature can also be output in °F by setting bit 3 of memory location 0x0F0 to 1. All other global configuration bits should be set to 0.

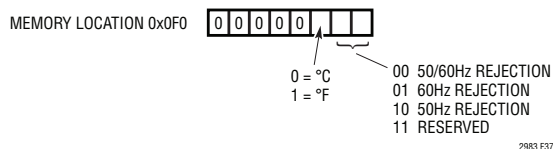

Figure 37. Global Configuration Register

Reference Considerations

The mechanical stress of soldering the LTC2983 to a PC board can cause the output voltage reference to shift and temperature coefficient to change. These two changes are not correlated. For example, the voltage may shift but the temperature coefficient may not. To reduce the effects of stress-related shifts, mount the reference near the short edge of the PC board or in a corner.

CUSTOM THERMOCOUPLES

In addition to digitizing standard thermocouples, the LTC2983 can also digitize user-programmable, custom thermocouples (thermocouple type=0b01001, see Table 12). Custom sensor data (minimum of three, maximum of 64 pairs) reside sequentially in memory and are arranged in blocks of six bytes of monotonically increasing tabular data as mV vs temperature (see Table 67).

Table 67. Custom Thermocouple Tabular Data Format

| ADDRESS | BYTE 0 | BYTE 1 | BYTE 2 | BYTE 3 | BYTE 4 | BYTE 5 |
|-------------------------------|----------------------|--------|--------------------------|--------|--------|--------|
| 0x250 + 6* Start Address | Table Entry #1 (mV) | | Table Entry #1 (Kelvin) | | | |
| 0x250 + 6* Start Address + 6 | Table Entry #2 (mV) | | Table Entry #2 (Kelvin) | | | |
| 0x250 + 6* Start Address + 12 | Table Entry #3 (mV) | | Table Entry #3 (Kelvin) | | | |
| | | | | | | |
| | | | | | | |
| | | | | | | |
| | | | | | | |
| | | | | | | |
| Max Address = 0x3CA | Table Entry #64 (mV) | | Table Entry #64 (Kelvin) | | | |

Custom Thermocouple Example

In this example, a simplified thermocouple curve is implemented (see Figure 38). Points P1 to P9 represent the normal operating range of the custom thermocouple. Voltage readings above point P9 result in a soft fault and the reported temperature is a linear extrapolation using

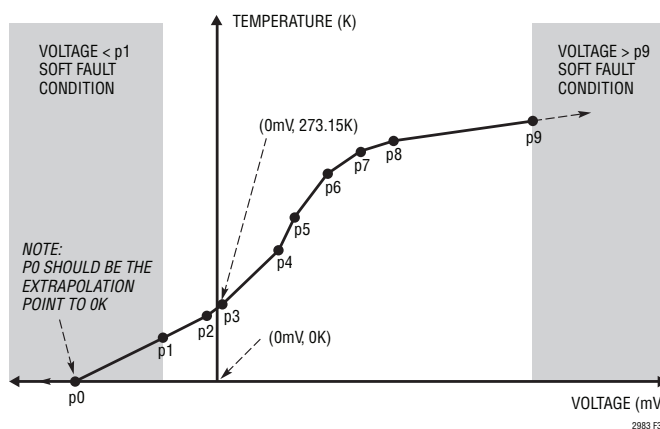

Figure 38. Custom Thermocouple Example (mV vs Kelvin)

CUSTOM THERMOCOUPLES

a slope determined by points P8 and P9 (the final two table entries). Voltage readings below point P1 are also reported as soft faults. The temperature reported is the extrapolation between point P1 and P0, where P0 is typically the sensor output voltage at 0 Kelvin. If P0 is above 0 Kelvin, then all sensor output voltages below P0 (in mV) will report 0 Kelvin.

In order to program the LTC2983 with the custom thermocouple table, both the mV data and the Kelvin data are converted to 24-bit binary values (represented as two 3-byte table entries). Since most thermocouples generate negative output voltages, the mV values input to the LTC2983 are 2's complement. The sensor output voltage (units=mV), follows the convention shown in Table 69, where the first bit is the sign, the next nine are the integer part and the remaining 14 bits are the fractional part.

Table 68. Thermocouple Example mV vs Kelvin (K) Data Memory Map

| POINT | SENSOR OUTPUT VOLTAGE (mV) | TEMPERATURE KELVIN | START ADDRESS | STOP ADDRESS | BYTE 0 | BYTE 1 | BYTE 2 | BYTE 3 | BYTE 4 | BYTE 5 |
|-------|----------------------------|--------------------|---------------|--------------|----------------|--------|--------|------------------|--------|--------|
| P0 | -50.22 | 0 | 0x250 | 0x255 | | | | | | |
| P1 | -30.2 | 99.1 | 0x256 | 0x25B | | | | | | |
| P2 | -5.3 | 135.4 | 0x25C | 0x261 | | | | | | |
| P3 | 0 | 273.15 | 0x262 | 0x267 | | | | | | |
| P4 | 40.2 | 361.2 | 0x268 | 0x26D | mV Data | | | Temperature Data | | |
| P5 | 55.3 | 522.1 | 0x26E | 0x273 | (see Table 69) | | | (see Table 70) | | |
| P6 | 88.3 | 720.3 | 0x274 | 0x279 | | | | | | |
| P7 | 132.2 | 811.2 | 0x27A | 0x27F | | | | | | |
| P8 | 188.7 | 922.5 | 0x280 | 0x285 | | | | | | |
| P9 | 460.4 | 1000 | 0x286 | 0x28B | | | | | | |

Table 69. Example Thermocouple Output Voltage Values (mV)

| mV | BYTE 0 | | | | | | | | | BYTE 1 | | | | | | | BYTE 2 | | | | | | | |
|--------|--------|-----|-----|-----|-----|-----|-----|-----|-----|--------|-----|-----|-----|-----|-----|----|--------|----|----|----|----|----|----|----|
| | Sign | B23 | B22 | B21 | B20 | B19 | B18 | B17 | B16 | B15 | B14 | B13 | B12 | B11 | B10 | B9 | B8 | B7 | B6 | B5 | B4 | B3 | B2 | B1 |
| -50.22 | 1 | 1 | 1 | 1 | 0 | 0 | 1 | 1 | 0 | 1 | 1 | 1 | 0 | 0 | 0 | 1 | 1 | 1 | 1 | 0 | 1 | 1 | 0 | 0 |
| -30.2 | 1 | 1 | 1 | 1 | 1 | 0 | 0 | 0 | 0 | 1 | 1 | 1 | 0 | 0 | 1 | 1 | 0 | 0 | 1 | 1 | 0 | 1 | 0 | 0 |
| -5.3 | 1 | 1 | 1 | 1 | 1 | 1 | 1 | 0 | 1 | 0 | 1 | 0 | 1 | 1 | 0 | 0 | 1 | 1 | 0 | 0 | 1 | 1 | 0 | 1 |
| 0 | 0 | 0 | 0 | 0 | 0 | 0 | 0 | 0 | 0 | 0 | 0 | 0 | 0 | 0 | 0 | 0 | 0 | 0 | 0 | 0 | 0 | 0 | 0 | 0 |
| 40.2 | 0 | 0 | 0 | 0 | 1 | 0 | 1 | 0 | 0 | 0 | 0 | 0 | 1 | 1 | 0 | 0 | 1 | 1 | 0 | 0 | 1 | 1 | 0 | 0 |
| 55.3 | 0 | 0 | 0 | 0 | 1 | 1 | 0 | 1 | 1 | 1 | 0 | 1 | 0 | 0 | 1 | 1 | 0 | 0 | 1 | 1 | 0 | 0 | 1 | 1 |
| 88.3 | 0 | 0 | 0 | 1 | 0 | 1 | 1 | 0 | 0 | 0 | 0 | 1 | 0 | 0 | 1 | 1 | 0 | 0 | 1 | 1 | 0 | 0 | 1 | 1 |
| 132.2 | 0 | 0 | 1 | 0 | 0 | 0 | 0 | 1 | 0 | 0 | 0 | 0 | 1 | 1 | 0 | 0 | 1 | 1 | 0 | 0 | 1 | 1 | 0 | 0 |
| 188.7 | 0 | 0 | 1 | 0 | 1 | 1 | 1 | 1 | 0 | 0 | 1 | 0 | 1 | 1 | 0 | 0 | 1 | 1 | 0 | 0 | 1 | 1 | 0 | 0 |
| 460.4 | 0 | 1 | 1 | 1 | 0 | 0 | 1 | 1 | 0 | 0 | 0 | 1 | 1 | 0 | 0 | 1 | 1 | 0 | 0 | 1 | 1 | 0 | 0 | 1 |

CUSTOM THERMOCOUPLES

In order to simplify the temperature field, temperature values are input in Kelvin as an unsigned value, but the final temperatures reported by the LTC2983 are reported in °C or °F. The sensor temperature (Kelvin), follows the convention shown in Table 70, where the first 14 bits are the integer part and the remaining 10 bits are the fractional part.

In this example, a custom thermocouple tied to CH1, with a cold junction sensor on CH2, is programmed with the

channel assignment data shown in Table 71 (refer to Figure 6 for similar format). In this case the custom data begins at memory location 0x250 (starting address is 0). The starting address (offset from 0x250) is entered in the custom thermocouple data pointer field of the channel assignment data. The table data length–1 (9 in this example) is entered into the custom thermocouple data length field of the thermocouple channel assignment word. Refer to Table 68 where the number of six byte entries is 10.

Table 70. Example Thermocouple Temperature Values

| | BYTE 3 | | | | | | | | | BYTE 4 | | | | | | BYTE 5 | | | | | | | | |
|-------------|-----------------|-----------------|-----------------|-----------------|----------------|----------------|----------------|----------------|----------------|----------------|----------------|----------------|----------------|----------------|-----------------|-----------------|-----------------|-----------------|-----------------|-----------------|-----------------|-----------------|-----------------|------------------|
| | B23 | B22 | B21 | B20 | B19 | B18 | B17 | B16 | B15 | B14 | B13 | B12 | B11 | B10 | B9 | B8 | B7 | B6 | B5 | B4 | B3 | B2 | B1 | B0 |
| Temperature | 2 ¹³ | 2 ¹² | 2 ¹¹ | 2 ¹⁰ | 2 ⁹ | 2 ⁸ | 2 ⁷ | 2 ⁶ | 2 ⁵ | 2 ⁴ | 2 ³ | 2 ² | 2 ¹ | 2 ⁰ | 2 ⁻¹ | 2 ⁻² | 2 ⁻³ | 2 ⁻⁴ | 2 ⁻⁵ | 2 ⁻⁶ | 2 ⁻⁷ | 2 ⁻⁸ | 2 ⁻⁹ | 2 ⁻¹⁰ |
| 0 | 0 | 0 | 0 | 0 | 0 | 0 | 0 | 0 | 0 | 0 | 0 | 0 | 0 | 0 | 0 | 0 | 0 | 0 | 0 | 0 | 0 | 0 | 0 | 0 |
| 99.1 | 0 | 0 | 0 | 0 | 0 | 0 | 0 | 1 | 1 | 0 | 0 | 0 | 1 | 1 | 0 | 0 | 0 | 1 | 1 | 0 | 0 | 1 | 1 | 0 |
| 135.4 | 0 | 0 | 0 | 0 | 0 | 0 | 1 | 0 | 0 | 0 | 0 | 1 | 1 | 1 | 0 | 1 | 1 | 0 | 0 | 1 | 1 | 0 | 0 | 1 |
| 273.15 | 0 | 0 | 0 | 0 | 0 | 1 | 0 | 0 | 0 | 1 | 0 | 0 | 0 | 1 | 0 | 0 | 1 | 0 | 0 | 1 | 1 | 0 | 0 | 1 |
| 361.2 | 0 | 0 | 0 | 0 | 0 | 1 | 0 | 1 | 1 | 0 | 1 | 0 | 0 | 1 | 0 | 0 | 1 | 1 | 0 | 0 | 1 | 1 | 0 | 0 |
| 522.1 | 0 | 0 | 0 | 0 | 1 | 0 | 0 | 0 | 0 | 0 | 1 | 0 | 1 | 0 | 0 | 0 | 0 | 1 | 1 | 0 | 0 | 1 | 1 | 0 |
| 720.3 | 0 | 0 | 0 | 0 | 1 | 0 | 1 | 1 | 0 | 1 | 0 | 0 | 0 | 0 | 1 | 0 | 0 | 1 | 1 | 0 | 0 | 1 | 1 | 1 |
| 811.2 | 0 | 0 | 0 | 0 | 1 | 1 | 0 | 0 | 1 | 0 | 1 | 0 | 1 | 1 | 0 | 0 | 1 | 1 | 0 | 0 | 1 | 1 | 0 | 0 |
| 922.5 | 0 | 0 | 0 | 0 | 1 | 1 | 1 | 0 | 0 | 1 | 1 | 0 | 1 | 0 | 1 | 0 | 0 | 0 | 0 | 0 | 0 | 0 | 0 | 0 |
| 1000 | 0 | 0 | 0 | 0 | 1 | 1 | 1 | 1 | 1 | 0 | 1 | 0 | 0 | 0 | 0 | 0 | 0 | 0 | 0 | 0 | 0 | 0 | 0 | 0 |

Table 71. Custom Thermocouple Channel Assignment Data

| CONFIGURATION FIELD | DESCRIPTION | # BITS | BINARY DATA | MEMORY ADDRESS 200 | MEMORY ADDRESS 201 | MEMORY ADDRESS 202 | MEMORY ADDRESS 203 | | | | | | | | | | | | | | | | | | | | |
|--------------------------------------|--|--------|-------------|--------------------|--------------------|--------------------|--------------------|---|---|---|---|---|---|---|---|---|---|---|---|---|---|---|---|---|---|---|---|
| (1) Thermocouple Type | Type Custom | 5 | 01001 | 0 | 1 | 0 | 0 | 1 | | | | | | | | | | | | | | | | | | | |
| (2) Cold Junction Channel Pointer | CH ₂ | 5 | 00010 | | | | | | 0 | 0 | 0 | 1 | 0 | | | | | | | | | | | | | | |
| (3) Sensor Configuration | Single-Ended, 10µA Open Circuit | 4 | 1100 | | | | | | | | | 1 | 1 | 0 | 0 | | | | | | | | | | | | |
| Not Used | Set These Bits to 0 | 6 | 000000 | | | | | | | | | | | | | 0 | 0 | 0 | 0 | 0 | 0 | | | | | | |
| (4) Custom Thermocouple Data Pointer | Start Address = 0 (Start at 0x250) | 6 | 000000 | | | | | | | | | | | | | | 0 | 0 | 0 | 0 | 0 | 0 | | | | | |
| Custom Thermocouple Data Length-1 | Data Length –1 = 9 (10 Paired Entries) | 6 | 001010 | | | | | | | | | | | | | | | | | | | 0 | 0 | 1 | 0 | 0 | 1 |

CUSTOM RTDS

In addition to digitizing standard RTDs, the LTC2983 can also digitize custom RTDs (RTD type=0b10010, see Table 26). Custom sensor data (minimum of three, maximum of 64 pairs) reside sequentially in memory and are arranged in blocks of six bytes of monotonically increasing tabular data Ω vs temperature (see Table 72).

Table 72. Custom RTD/Thermistor Tabular Data Format

| ADDRESS | BYTE 0 | BYTE 1 | BYTE 2 | BYTE 3 | BYTE 4 | BYTE 5 |
|-------------------------------|------------------------------|--------|--------------------------|--------|--------|--------|
| 0x250 + 6* Start Address | Table Entry #1 (Ω) | | Table Entry #1 (Kelvin) | | | |
| 0x250 + 6* Start Address + 6 | Table Entry #2 (Ω) | | Table Entry #2 (Kelvin) | | | |
| 0x250 + 6* Start Address + 12 | Table Entry #3 (Ω) | | Table Entry #3 (Kelvin) | | | |
| • | • | | • | | | |
| • | • | | • | | | |
| • | • | | • | | | |
| • | • | | • | | | |
| • | • | | • | | | |
| • | • | | • | | | |
| Max Address = 0x3CA | Table Entry #64 (Ω) | | Table Entry #64 (Kelvin) | | | |

Custom RTD Example

In this example, a simplified RTD curve is implemented (see Figure 39). Points P1 to P9 represent the normal operating range of the custom RTD. Resistance readings above point P9 result in a soft fault and the reported temperature is a linear extrapolation using a slope determined by points P8 and P9 (the final two table entries). Resistance readings below point P1 are also reported as soft faults. The temperature reported is the extrapolation between point P1 and P0, where P0 is the sensor output temperature at 0Ω (This point should be 0Ω for proper interpolation below point p1).

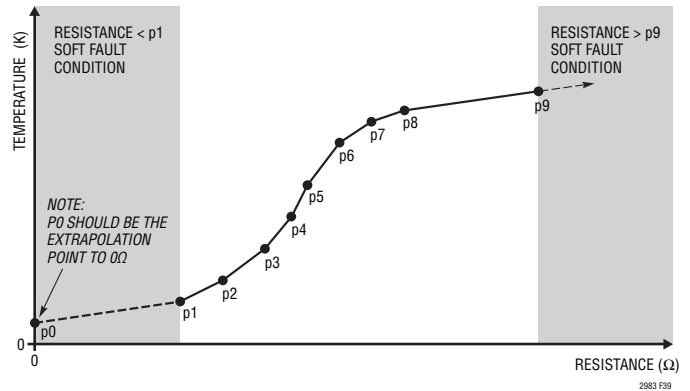

Figure 39. Custom RTD Example (Ω vs Kelvin)

CUSTOM RTDS

Custom RTD table data is formatted in Ω (sensor output resistance) vs Kelvin (see Table 73). Each table entry pair spans six bytes. The first set of data can begin at any memory location greater than or equal to 0x250 and end at or below 0x3CF.

In order to program the LTC2983 with the custom RTD table, both the resistance data and the Kelvin data are converted to 24-bit binary values. The sensor output

resistance (units= Ω) follows the convention shown in Table 74, where the first 13 bits are the integer part and the remaining 11 bits are the fractional part.

In order to simplify the temperature field, temperature values are input in Kelvin as an unsigned value, but the final temperatures reported by the LTC2983 are reported in $^{\circ}\text{C}$ or $^{\circ}\text{F}$. The sensor temperature (Kelvin) follows the

Table 73. RTD Example Resistance vs Kelvin Data Memory Map

| POINT | SENSOR OUTPUT RESISTANCE (Ω) | TEMPERATURE (K) | START ADDRESS | STOP ADDRESS | BYTE 1 | BYTE 2 | BYTE 3 | BYTE 1 | BYTE 2 | BYTE 3 |
|-------|---------------------------------------|-----------------|---------------|--------------|-----------------|--------|--------|------------------|--------|--------|
| P0 | 0 | 112.3 | 0x28C | 0x291 | | | | | | |
| P1 | 80 | 200.56 | 0x292 | 0x297 | | | | | | |
| P2 | 150 | 273.16 | 0x298 | 0x29D | | | | | | |
| P3 | 257.36 | 377.25 | 0x29E | 0x2A3 | | | | | | |
| P4 | 339.22 | 489.66 | 0x2A4 | 0x2A9 | Resistance Data | | | Temperature Data | | |
| P5 | 388.26 | 595.22 | 0x2AA | 0x2AF | | | | | | |
| P6 | 512.99 | 697.87 | 0x2B0 | 0x2B5 | | | | | | |
| P7 | 662.3 | 765.14 | 0x2B6 | 0x2BB | | | | | | |
| P8 | 743.5 | 801.22 | 0x2BC | 0x2C1 | | | | | | |
| P9 | 2001.89 | 900.5 | 0x2C2 | 0x2C7 | | | | | | |

Table 74. Example RTD Resistance Values

| | BYTE 1 | | | | | | | | | BYTE 2 | | | | | | | BYTE 3 | | | | | | | |
|------------|-----------------|-----------------|-----------------|----------------|----------------|----------------|----------------|----------------|----------------|----------------|----------------|----------------|----------------|-----------------|-----------------|-----------------|-----------------|-----------------|-----------------|-----------------|-----------------|-----------------|------------------|------------------|
| | B23 | B22 | B21 | B20 | B19 | B18 | B17 | B16 | B15 | B14 | B13 | B12 | B11 | B10 | B9 | B8 | B7 | B6 | B5 | B4 | B3 | B2 | B1 | B0 |
| Resistance | 2 ¹² | 2 ¹¹ | 2 ¹⁰ | 2 ⁹ | 2 ⁸ | 2 ⁷ | 2 ⁶ | 2 ⁵ | 2 ⁴ | 2 ³ | 2 ² | 2 ¹ | 2 ⁰ | 2 ⁻¹ | 2 ⁻² | 2 ⁻³ | 2 ⁻⁴ | 2 ⁻⁵ | 2 ⁻⁶ | 2 ⁻⁷ | 2 ⁻⁸ | 2 ⁻⁹ | 2 ⁻¹⁰ | 2 ⁻¹¹ |
| 0 | 0 | 0 | 0 | 0 | 0 | 0 | 0 | 0 | 0 | 0 | 0 | 0 | 0 | 0 | 0 | 0 | 0 | 0 | 0 | 0 | 0 | 0 | 0 | 0 |
| 80 | 0 | 0 | 0 | 0 | 0 | 0 | 1 | 0 | 1 | 0 | 0 | 0 | 0 | 0 | 0 | 0 | 0 | 0 | 0 | 0 | 0 | 0 | 0 | 0 |
| 150 | 0 | 0 | 0 | 0 | 0 | 1 | 0 | 0 | 1 | 0 | 1 | 1 | 0 | 0 | 0 | 0 | 0 | 0 | 0 | 0 | 0 | 0 | 0 | 0 |
| 257.36 | 0 | 0 | 0 | 0 | 1 | 0 | 0 | 0 | 0 | 0 | 0 | 1 | 0 | 1 | 0 | 1 | 1 | 1 | 0 | 0 | 0 | 0 | 0 | 1 |
| 339.22 | 0 | 0 | 0 | 0 | 1 | 0 | 1 | 0 | 1 | 0 | 0 | 1 | 1 | 0 | 0 | 1 | 1 | 0 | 0 | 0 | 0 | 0 | 1 | 0 |
| 388.26 | 0 | 0 | 0 | 0 | 1 | 1 | 0 | 0 | 0 | 0 | 1 | 0 | 0 | 0 | 1 | 0 | 0 | 0 | 1 | 0 | 1 | 0 | 0 | 0 |
| 512.99 | 0 | 0 | 0 | 1 | 0 | 0 | 0 | 0 | 0 | 0 | 0 | 0 | 1 | 1 | 1 | 1 | 1 | 1 | 0 | 1 | 0 | 1 | 1 | 1 |
| 662.3 | 0 | 0 | 0 | 1 | 0 | 1 | 0 | 0 | 1 | 0 | 1 | 1 | 0 | 0 | 1 | 0 | 0 | 1 | 1 | 0 | 0 | 1 | 1 | 0 |
| 743.5 | 0 | 0 | 0 | 1 | 0 | 1 | 1 | 1 | 0 | 0 | 1 | 1 | 1 | 1 | 0 | 0 | 0 | 0 | 0 | 0 | 0 | 0 | 0 | 0 |
| 2001.89 | 0 | 0 | 1 | 1 | 1 | 1 | 1 | 0 | 1 | 0 | 0 | 0 | 1 | 1 | 1 | 1 | 0 | 0 | 0 | 1 | 1 | 1 | 1 | 0 |

CUSTOM RTDS

convention shown in Table 75, where the first 14 bits are the integer part and the remaining 10 bits are the fractional part.

In this example, a custom RTD tied to CH12/13, with a sense resistor on CH10/11, is programmed with the channel assignment data shown in Table 76 (refer to Figure 15 for a similar format). In this case, the custom data begins

at memory location 0x28C (starting address is 10). The starting address (offset from 0x250) is entered in the custom RTD data pointer field of the channel assignment data. The table data length -1 (9 in this case) is entered into the custom RTD data length field of the channel assignment word. Refer to Table 72 where the total number of paired entries is 10.

Table 75. Example RTD Temperature Values

| | BYTE 1 | | | | | | | | | | BYTE 2 | | | | | | | | BYTE 3 | | | | | | | | | |
|-------------|-----------------|-----------------|-----------------|-----------------|----------------|----------------|----------------|----------------|----------------|----------------|----------------|----------------|----------------|----------------|-----------------|-----------------|-----------------|-----------------|-----------------|-----------------|-----------------|-----------------|-----------------|------------------|--|--|--|--|
| | B23 | B22 | B21 | B20 | B19 | B18 | B17 | B16 | B15 | B14 | B13 | B12 | B11 | B10 | B9 | B8 | B7 | B6 | B5 | B4 | B3 | B2 | B1 | B0 | | | | |
| Temperature | 2 ¹³ | 2 ¹² | 2 ¹¹ | 2 ¹⁰ | 2 ⁹ | 2 ⁸ | 2 ⁷ | 2 ⁶ | 2 ⁵ | 2 ⁴ | 2 ³ | 2 ² | 2 ¹ | 2 ⁰ | 2 ⁻¹ | 2 ⁻² | 2 ⁻³ | 2 ⁻⁴ | 2 ⁻⁵ | 2 ⁻⁶ | 2 ⁻⁷ | 2 ⁻⁸ | 2 ⁻⁹ | 2 ⁻¹⁰ | | | | |
| 112.3 | 0 | 0 | 0 | 0 | 0 | 0 | 0 | 1 | 1 | 1 | 0 | 0 | 0 | 0 | 0 | 1 | 0 | 0 | 1 | 1 | 0 | 0 | 1 | 1 | | | | |
| 200.56 | 0 | 0 | 0 | 0 | 0 | 0 | 1 | 1 | 0 | 0 | 1 | 0 | 0 | 0 | 1 | 0 | 0 | 0 | 1 | 1 | 1 | 1 | 0 | 1 | | | | |
| 273.16 | 0 | 0 | 0 | 0 | 0 | 0 | 1 | 0 | 0 | 1 | 0 | 0 | 0 | 1 | 0 | 0 | 1 | 0 | 1 | 0 | 0 | 0 | 1 | 1 | | | | |
| 377.25 | 0 | 0 | 0 | 0 | 0 | 0 | 1 | 1 | 1 | 1 | 1 | 0 | 0 | 1 | 0 | 1 | 0 | 0 | 0 | 0 | 0 | 0 | 0 | 0 | | | | |
| 489.66 | 0 | 0 | 0 | 0 | 0 | 0 | 0 | 1 | 1 | 0 | 1 | 0 | 0 | 1 | 1 | 0 | 1 | 0 | 1 | 0 | 0 | 0 | 1 | 1 | | | | |
| 595.22 | 0 | 0 | 0 | 0 | 1 | 0 | 0 | 1 | 0 | 1 | 0 | 0 | 1 | 1 | 0 | 0 | 1 | 1 | 1 | 0 | 0 | 0 | 0 | 1 | | | | |
| 697.87 | 0 | 0 | 0 | 0 | 1 | 0 | 1 | 0 | 1 | 1 | 1 | 0 | 0 | 1 | 1 | 1 | 0 | 1 | 1 | 1 | 1 | 0 | 1 | 0 | | | | |
| 765.14 | 0 | 0 | 0 | 0 | 1 | 1 | 0 | 1 | 1 | 1 | 1 | 1 | 0 | 1 | 0 | 0 | 1 | 0 | 0 | 0 | 1 | 1 | 1 | 1 | | | | |
| 801.22 | 0 | 0 | 0 | 0 | 1 | 0 | 1 | 0 | 1 | 0 | 0 | 0 | 0 | 1 | 0 | 0 | 1 | 1 | 1 | 0 | 0 | 0 | 0 | 1 | | | | |
| 900.5 | 0 | 0 | 0 | 0 | 1 | 1 | 1 | 0 | 0 | 0 | 0 | 1 | 0 | 0 | 1 | 0 | 0 | 0 | 0 | 0 | 0 | 0 | 0 | 0 | | | | |

Table 76. Custom RTD Channel Assignment Data

| CONFIGURATION FIELD | DESCRIPTION | # BITS | BINARY DATA | MEMORY ADDRESS 230 | MEMORY ADDRESS 231 | MEMORY ADDRESS 232 | MEMORY ADDRESS 233 | | | | | | | | | | | | | | | | | | |
|------------------------------------|---|--------|-------------|--------------------|--------------------|--------------------|--------------------|---|---|---|---|---|---|---|---|---|---|---|---|---|---|--|--|--|--|
| (1) RTD Type | Custom | 5 | 10010 | 1 | 0 | 0 | 1 | 0 | | | | | | | | | | | | | | | | | |
| (2) Sense Resistor Channel Pointer | CH ₁₁ | 5 | 01011 | | | | | | 0 | 1 | 0 | 1 | 1 | | | | | | | | | | | | |
| (3) Sensor Configuration | 4-Wire, No Rotate, No Share | 4 | 1000 | | | | | | | | | | | 1 | 0 | 0 | 0 | | | | | | | | |
| (4) Excitation Current | 25μA | 4 | 0011 | | | | | | | | | | | | | | | 0 | 0 | 1 | 1 | | | | |
| (5) Standard | Not Used for Custom | 2 | 00 | | | | | | | | | | | | | | | | | | | | | | |
| (6) Custom RTD Data Pointer | Start Address = 10 | 6 | 001010 | | | | | | | | | | | | | | | | | | | | | | |
| (6) Custom RTD Data Length-1 | Data Length -1 = 9 10 Paired Entries | 6 | 001001 | | | | | | | | | | | | | | | | | | | | | | |

CUSTOM THERMISTORS

In addition to digitizing standard thermistors, the LTC2983 can also digitize custom thermistors (thermistor type=0b11011, see Table 51). Custom sensor data (minimum of three, maximum of 64 pairs) reside sequentially in memory and are arranged in blocks of six bytes of monotonically increasing tabular data Ω vs temperature (see Table 72).

Custom Thermistor Table Example

In this example, a simplified thermistor NTC (negative temperature coefficient) curve is implemented (see Figure 40). Points P1 to P9 represent the normal operating range of the custom thermistor. Resistance readings above point

P9 result in a soft fault and the reported temperature is a linear extrapolation using a slope determined by points P8 and P9 (the final two table entries). Resistance readings below point P1 are also reported as soft faults. The temperature reported is the extrapolation between point P1 and P0, where P0 is the sensor output temperature at 0Ω (This point must be 0Ω for proper interpolation below point p1).

In addition to NTC type thermistors, it is also possible to implement PTC (positive temperature coefficient) type thermistors (see Figure 41). In both cases, table entries start at the minimum resistance and end at the maximum resistance value.

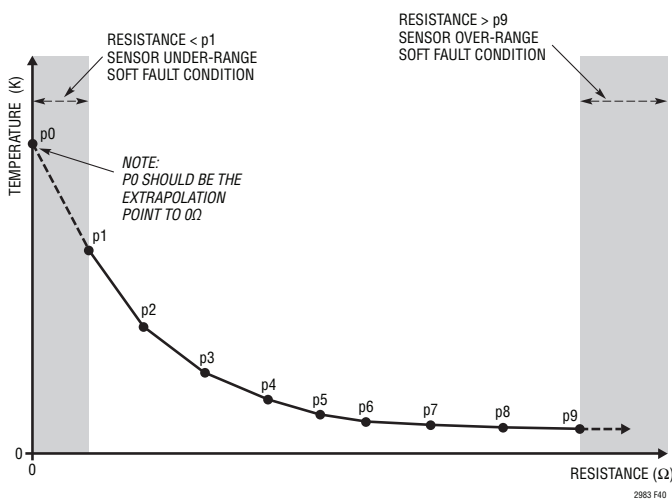

Figure 40. Custom NTC Thermistor Example (Ω vs Kelvin)

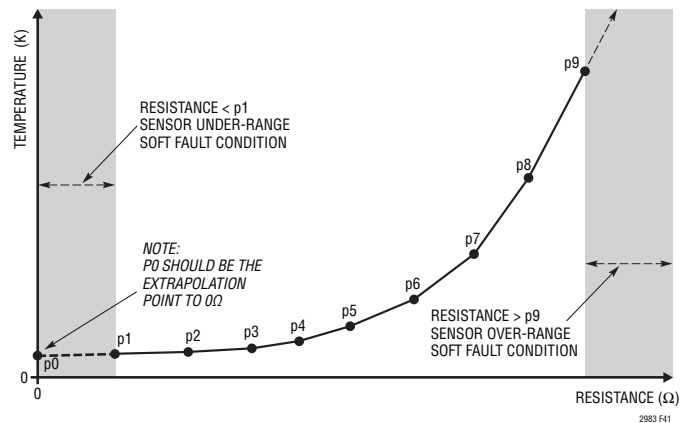

Figure 41. Custom PTC Thermistor Example (Ω vs Kelvin)

CUSTOM THERMISTORS

Custom thermistor table data is formatted in Ω (sensor output resistance) vs Kelvin (see Table 77). Each table entry pair spans six bytes. The first set of data can begin at any memory location greater than or equal to 0x250 and end below 0x3CF.

In order to program the LTC2983 with the custom thermistor table, both the resistance data and the Kelvin data are converted to 24-bit binary values. The sensor output resistance (units= Ω) follows the convention shown in

Table 78, where the first 20 bits are the integer part and the remaining four bits are the fractional part.

In order to simplify the temperature field, temperature values are input in Kelvin as an unsigned value, but the final temperatures reported by the LTC2983 are reported in $^{\circ}\text{C}$ or $^{\circ}\text{F}$. The sensor temperature (Kelvin) follows the convention shown in Table 79, where the first 14 bits are the integer part and the remaining 10 bits are the fractional part.

Table 77. NTC Thermistor Example Resistance vs Kelvin Data Memory Map

| POINT | SENSOR OUTPUT RESISTANCE(Ω) | TEMPERATURE (K) | START ADDRESS | STOP ADDRESS | BYTE 1 | BYTE 2 | BYTE 3 | BYTE 1 | BYTE 2 | BYTE 3 |
|-------|--------------------------------------|-----------------|---------------|--------------|-----------------|--------|--------|------------------|--------|--------|
| P0 | 0 | 457.5 | 0x2C8 | 0x2CD | | | | | | |
| P1 | 80 | 400.2 | 0x2CE | 0x2D3 | | | | | | |
| P2 | 184 | 372.3 | 0x2D4 | 0x2D9 | | | | | | |
| P3 | 423.2 | 320.1 | 0x2DA | 0x2DF | | | | | | |
| P4 | 973.36 | 290.55 | 0x2E0 | 0x2E5 | Resistance Data | | | Temperature Data | | |
| P5 | 2238.728 | 249.32 | 0x2E6 | 0x2EB | | | | | | |
| P6 | 5149.0744 | 240.3 | 0x2EC | 0x2F1 | | | | | | |
| P7 | 26775.18688 | 230 | 0x2F2 | 0x2F7 | | | | | | |
| P8 | 139230.9718 | 215.3 | 0x2F8 | 0x2FD | | | | | | |
| P9 | 724001.0532 | 200 | 0x2FE | 0x303 | | | | | | |

Table 78. Example Thermistor Resistance Values

| Resistance | BYTE 1 | | | | | | | | BYTE 2 | | | | | | | | BYTE 3 | | | | | | | |
|------------|--------|-----|-----|-----|-----|-----|-----|-----|--------|-----|-----|-----|-----|-----|----|----|--------|----|----|----|----|----|----|----|
| | B23 | B22 | B21 | B20 | B19 | B18 | B17 | B16 | B15 | B14 | B13 | B12 | B11 | B10 | B9 | B8 | B7 | B6 | B5 | B4 | B3 | B2 | B1 | B0 |
| 0 | 0 | 0 | 0 | 0 | 0 | 0 | 0 | 0 | 0 | 0 | 0 | 0 | 0 | 0 | 0 | 0 | 0 | 0 | 0 | 0 | 0 | 0 | 0 | 0 |
| 80 | 0 | 0 | 0 | 0 | 0 | 0 | 0 | 0 | 0 | 0 | 0 | 0 | 0 | 1 | 0 | 1 | 0 | 0 | 0 | 0 | 0 | 0 | 0 | 0 |
| 184 | 0 | 0 | 0 | 0 | 0 | 0 | 0 | 0 | 0 | 0 | 0 | 0 | 1 | 0 | 1 | 1 | 1 | 0 | 0 | 0 | 0 | 0 | 0 | 0 |
| 423.2 | 0 | 0 | 0 | 0 | 0 | 0 | 0 | 0 | 0 | 0 | 0 | 1 | 1 | 0 | 1 | 0 | 0 | 1 | 1 | 1 | 0 | 0 | 1 | 1 |
| 973.36 | 0 | 0 | 0 | 0 | 0 | 0 | 0 | 0 | 0 | 1 | 1 | 1 | 1 | 0 | 0 | 1 | 1 | 0 | 1 | 0 | 1 | 0 | 1 | 1 |
| 2238.728 | 0 | 0 | 0 | 0 | 0 | 0 | 0 | 0 | 1 | 0 | 0 | 0 | 1 | 0 | 1 | 1 | 1 | 1 | 0 | 1 | 0 | 1 | 1 | 1 |
| 5149.074 | 0 | 0 | 0 | 0 | 0 | 0 | 0 | 1 | 0 | 1 | 0 | 0 | 0 | 0 | 1 | 1 | 1 | 0 | 1 | 0 | 0 | 0 | 1 | 1 |
| 26775.19 | 0 | 0 | 0 | 0 | 0 | 1 | 1 | 0 | 1 | 0 | 0 | 0 | 1 | 0 | 0 | 1 | 0 | 1 | 1 | 1 | 0 | 0 | 1 | 1 |
| 139231 | 0 | 0 | 1 | 0 | 0 | 0 | 0 | 1 | 1 | 1 | 1 | 1 | 1 | 0 | 1 | 1 | 1 | 1 | 1 | 0 | 0 | 0 | 0 | 0 |
| 724001.1 | 1 | 0 | 1 | 1 | 0 | 0 | 0 | 0 | 1 | 1 | 0 | 0 | 0 | 0 | 1 | 0 | 0 | 0 | 1 | 0 | 0 | 0 | 0 | 1 |

CUSTOM THERMISTORS

In this example, a custom thermistor tied to CH5, with a sense resistor on CH3/4, is programmed with the channel assignment data shown in Table 80 (refer to Figure 24 for similar format). In this case the custom data begins at memory location 0x2C8 (starting address is 20). The

starting address (offset from 0x250) is entered in the custom thermistor data pointer field of the channel assignment data. The table data length -1 (9 in this case) is entered into the custom thermistor data length field of the thermistor channel assignment word.

Table 79. Example Thermistor Temperature Values

| | BYTE 1 | | | | | | | | | | BYTE 2 | | | | | | BYTE 3 | | | | | | | |
|-------------|-----------------|-----------------|-----------------|-----------------|----------------|----------------|----------------|----------------|----------------|----------------|----------------|----------------|----------------|----------------|-----------------|-----------------|-----------------|-----------------|-----------------|-----------------|-----------------|-----------------|-----------------|------------------|
| | B23 | B22 | B21 | B20 | B19 | B18 | B17 | B16 | B15 | B14 | B13 | B12 | B11 | B10 | B9 | B8 | B7 | B6 | B5 | B4 | B3 | B2 | B1 | B0 |
| Temperature | 2 ¹³ | 2 ¹² | 2 ¹¹ | 2 ¹⁰ | 2 ⁹ | 2 ⁸ | 2 ⁷ | 2 ⁶ | 2 ⁵ | 2 ⁴ | 2 ³ | 2 ² | 2 ¹ | 2 ⁰ | 2 ⁻¹ | 2 ⁻² | 2 ⁻³ | 2 ⁻⁴ | 2 ⁻⁵ | 2 ⁻⁶ | 2 ⁻⁷ | 2 ⁻⁸ | 2 ⁻⁹ | 2 ⁻¹⁰ |
| 457.5 | 0 | 0 | 0 | 0 | 0 | 1 | 1 | 1 | 0 | 0 | 1 | 0 | 0 | 1 | 1 | 0 | 0 | 0 | 0 | 0 | 0 | 0 | 0 | 0 |
| 400.2 | 0 | 0 | 0 | 0 | 0 | 1 | 1 | 0 | 0 | 1 | 0 | 0 | 0 | 0 | 0 | 0 | 1 | 1 | 0 | 0 | 1 | 1 | 0 | 0 |
| 372.3 | 0 | 0 | 0 | 0 | 0 | 1 | 0 | 1 | 1 | 1 | 0 | 1 | 0 | 0 | 0 | 1 | 0 | 0 | 1 | 1 | 0 | 0 | 1 | 1 |
| 320.1 | 0 | 0 | 0 | 0 | 0 | 1 | 0 | 1 | 0 | 0 | 0 | 0 | 0 | 0 | 0 | 0 | 0 | 1 | 1 | 0 | 0 | 1 | 1 | 0 |
| 290.55 | 0 | 0 | 0 | 0 | 0 | 1 | 0 | 0 | 1 | 0 | 0 | 0 | 1 | 0 | 1 | 0 | 0 | 0 | 1 | 1 | 0 | 0 | 1 | 1 |
| 249.32 | 0 | 0 | 0 | 0 | 0 | 0 | 1 | 1 | 1 | 1 | 1 | 0 | 0 | 1 | 0 | 1 | 0 | 1 | 0 | 0 | 0 | 1 | 1 | 1 |
| 240.3 | 0 | 0 | 0 | 0 | 0 | 0 | 1 | 1 | 1 | 1 | 0 | 0 | 0 | 0 | 0 | 1 | 0 | 0 | 1 | 1 | 0 | 0 | 1 | 1 |
| 230 | 0 | 0 | 0 | 0 | 0 | 0 | 1 | 1 | 1 | 0 | 0 | 1 | 1 | 0 | 0 | 0 | 0 | 0 | 0 | 0 | 0 | 0 | 0 | 0 |
| 215.3 | 0 | 0 | 0 | 0 | 0 | 0 | 1 | 1 | 0 | 1 | 0 | 1 | 1 | 1 | 0 | 1 | 0 | 0 | 1 | 1 | 0 | 0 | 1 | 1 |
| 200 | 0 | 0 | 0 | 0 | 0 | 0 | 1 | 1 | 0 | 0 | 1 | 0 | 0 | 0 | 0 | 0 | 0 | 0 | 0 | 0 | 0 | 0 | 0 | 0 |

Table 80. Custom Thermistor Channel Assignment Data

| CONFIGURATION FIELD | DESCRIPTION | # BITS | BINARY DATA | MEMORY ADDRESS 210 | MEMORY ADDRESS 211 | MEMORY ADDRESS 212 | MEMORY ADDRESS 213 | | | | | | | | | | | | | | | | | | | | | |
|------------------------------------|---------------------|--------|-------------|--------------------|--------------------|--------------------|--------------------|---|---|---|---|---|---|---|---|---|---|---|---|---|---|---|---|---|---|---|---|---|
| (1) Thermistor Type | Custom Table | 5 | 11011 | 1 | 1 | 0 | 1 | 1 | | | | | | | | | | | | | | | | | | | | |
| (2) Sense Resistor Channel Pointer | CH ₄ | 5 | 00100 | | | | | | 0 | 0 | 1 | 0 | 0 | | | | | | | | | | | | | | | |
| (3) Sensor Configuration | Single-Ended | 3 | 100 | | | | | | | | | | 1 | 0 | 0 | | | | | | | | | | | | | |
| (4) Excitation Current | 1μA | 4 | 0011 | | | | | | | | | | | | 0 | 0 | 1 | 1 | | | | | | | | | | |
| Not Used | Set These Bits to 0 | 2 | 00 | | | | | | | | | | | | | | | 0 | 0 | 0 | | | | | | | | |
| (5) Custom Thermistor Data Pointer | Start Address = 20 | 6 | 010100 | | | | | | | | | | | | | | | | | 0 | 1 | 0 | 1 | 0 | 0 | | | |
| (5) Custom Thermistor Length-1 | Length -1 = 9 | 6 | 001001 | | | | | | | | | | | | | | | | | | | | 0 | 0 | 1 | 0 | 0 | 1 |

CUSTOM THERMISTORS

In addition to custom table driven thermistors, it is also possible to directly input Steinhart-Hart coefficients into the LTC2983 (thermistor type 11010, see Table 51). Steinhart-Hart coefficients are commonly specified parameters provided by thermistor manufacturers. The Steinhart-Hart equation is:

$$\frac{1}{T} = A + B \cdot \ln(R) + C \cdot \ln(R)^2 + D \cdot \ln(R)^3 + E \cdot \ln(R)^4 + F \cdot \ln(R)^5$$

Steinhart-Hart data is stored sequentially in any memory location greater than or equal to 0x250 and below 0x3CF. Each coefficient is represented by a standard, single-precision, IEEE754 32-bit value (see Table 81).

Example Custom Steinhart-Hart Thermistor

In this example a Steinhart-Hart equation is entered into memory starting at location 0x300 (see Table 82).

Table 81. Steinhart-Hart Custom Thermistor Data Format

| ADDRESS | COEFFICIENT | VALUE |
|--------------------------------|-------------|---|
| 0x250 + 4 * Start Address | A | 32-Bit Single-Precision Floating Point Format |
| 0x250 + 4 * Start Address + 4 | B | 32-Bit Single-Precision Floating Point Format |
| 0x250 + 4 * Start Address + 8 | C | 32-Bit Single-Precision Floating Point Format |
| 0x250 + 4 * Start Address + 12 | D | 32-Bit Single-Precision Floating Point Format |
| 0x250 + 4 * Start Address + 16 | E | 32-Bit Single-Precision Floating Point Format |
| 0x250 + 4 * Start Address + 20 | F | 32-Bit Single-Precision Floating Point Format |

Table 82. Custom Steinhart-Hart Data Example

| COEFFICIENT | VALUE | START ADDRESS | SIGN | EXPONENT | | | | | | | | MANTISSA | | | | | | | | | | | | | | | | | | | | | | | |
|-------------|----------|---------------|------|----------|---|---|---|-----|---|---|---|----------|---|---|---|---|---|---|---|---|---|---|---|-----|---|---|---|---|---|---|---|---|---|---|---|
| | | | | MSB | | | | LSB | | | | MSB | | | | | | | | | | | | LSB | | | | | | | | | | | |
| A | 1.45E-03 | 0x300 | 0 | 0 | 1 | 1 | 1 | 0 | 1 | 0 | 1 | 0 | 1 | 1 | 1 | 1 | 1 | 0 | 0 | 0 | 0 | 0 | 0 | 1 | 1 | 0 | 1 | 1 | 1 | 1 | 0 | 1 | 1 | 0 | 1 |
| B | 2.68E-04 | 0x304 | 0 | 0 | 1 | 1 | 1 | 0 | 0 | 1 | 1 | 0 | 0 | 0 | 1 | 1 | 0 | 0 | 1 | 0 | 0 | 0 | 0 | 0 | 0 | 1 | 0 | 0 | 1 | 0 | 1 | 1 | 0 | 1 | 0 |
| C | 0 | 0x308 | 0 | 0 | 0 | 0 | 0 | 0 | 0 | 0 | 0 | 0 | 0 | 0 | 0 | 0 | 0 | 0 | 0 | 0 | 0 | 0 | 0 | 0 | 0 | 0 | 0 | 0 | 0 | 0 | 0 | 0 | 0 | 0 | 0 |
| D | 1.64E-07 | 0x30C | 0 | 0 | 1 | 1 | 0 | 1 | 0 | 0 | 0 | 0 | 1 | 1 | 0 | 0 | 0 | 0 | 0 | 0 | 0 | 1 | 0 | 1 | 1 | 1 | 1 | 1 | 1 | 1 | 1 | 1 | 0 | 1 | 0 |
| E | 0 | 0x310 | 0 | 0 | 0 | 0 | 0 | 0 | 0 | 0 | 0 | 0 | 0 | 0 | 0 | 0 | 0 | 0 | 0 | 0 | 0 | 0 | 0 | 0 | 0 | 0 | 0 | 0 | 0 | 0 | 0 | 0 | 0 | 0 | 0 |
| F | 0 | 0x314 | 0 | 0 | 0 | 0 | 0 | 0 | 0 | 0 | 0 | 0 | 0 | 0 | 0 | 0 | 0 | 0 | 0 | 0 | 0 | 0 | 0 | 0 | 0 | 0 | 0 | 0 | 0 | 0 | 0 | 0 | 0 | 0 | 0 |

CUSTOM THERMISTORS

Table 83. Custom Steinhart-Hart Channel Assignment Data

| CONFIGURATION FIELD | DESCRIPTION | # BITS | BINARY DATA | MEMORY ADDRESS 210 | MEMORY ADDRESS 211 | MEMORY ADDRESS 212 | MEMORY ADDRESS 213 |
|--|---------------------------|--------|-------------|--------------------|--------------------|--------------------|--------------------|
| (1) Thermistor Type | Custom Steinhart-Hart | 5 | 11010 | 1 1 0 1 0 | | | |
| (2) Sense Resistor Channel Pointer | CH ₄ | 5 | 00100 | | 0 0 1 0 0 | | |
| (3) Sensor Configuration | Single-Ended | 3 | 100 | | 1 0 0 | | |
| (4) Excitation Current | 1 μ A | 4 | 0011 | | | 0 0 1 1 | |
| Not Used | Set These Bits to 0 | 2 | 00 | | | 0 0 0 | |
| (5) Custom Thermistor Data Pointer | Start Address = 30 | 6 | 011110 | | | | 0 1 1 1 1 0 |
| (5) Custom Steinhart-Hart Length Always Set to 0 | Fixed at Six 32-Bit Words | 6 | 000000 | | | | 0 0 0 0 0 0 |

A custom thermistor tied to CH5, with a sense resistor on CH3/4, is programmed with the channel assignment data shown in Table 83 (refer to Figure 24 for a similar format). In this case the custom data begins at memory location 0x300 (starting address is 30). The starting address (offset from 0x250) is entered in the custom thermistor data pointer field of the channel assignment data. The data length (set to 0) is always six 32-bit floating point words.

Universal Sensor Hardware

The LTC2983 can be configured as a universal temperature measurement device. Up to four sets of universal inputs can be applied to a single LTC2983. Each of these sets can directly digitize a 3-wire RTD, 4-Wire RTD, Thermistor, or thermocouple without changing any on board hardware (see Figure 42). Each sensor can share the same four ADC inputs and protection/filtering circuitry are configured using software changes (new channel assignment data) only. One sense resistor and cold junction sensor are shared among all four banks of sensors.

The LTC2983 includes many flexible, software configurable input modes. In order to share four common inputs among all four sensor types each sensor requires specific configuration bits (see Table 84). 3-Wire RTDs are configured with shared R_{SENSE}, 4-Wire RTDs and thermistors are configured as shared and/or rotated, thermocouples are configured differential with internal ground, and diodes are configured as single-ended.

Table 84. Sensor Configuration for Universal Hookup

| SENSOR TYPE | CONFIGURATION OPTIONS | CONFIGURATION BITS | SEE TABLE |
|--------------|-----------------------|--------------------|-----------|
| 3-WIRE RTD | Share | B18 = 1, B19 = 0 | Table 28 |
| 4-WIRE RTD | Share | B18 = 1, B19 = 0 | Table 28 |
| 4-WIRE RTD | Rotate | B18 = 0, B19 = 1 | Table 28 |
| Thermistor | Share | B19 = 0, B20 = 1 | Table 52 |
| Thermistor | Rotate | B19 = 1, B20 = 0 | Table 52 |
| Thermocouple | Single-Ended | B21 = 1 | Table 14 |
| Diode | Single-Ended | B26 = 1 | Table 17 |

PACKAGE DESCRIPTION

Please refer to <http://www.linear.com/designtools/packaging/> for the most recent package drawings.

LX Package
48-Lead Plastic LQFP (7mm × 7mm)
 (Reference LTC DWG # 05-08-1760 Rev A)

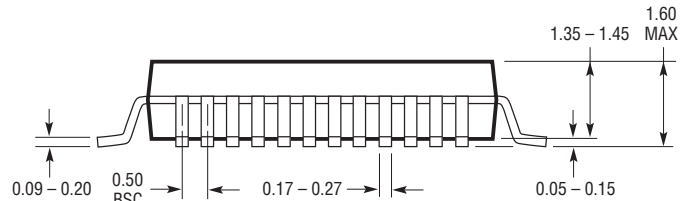
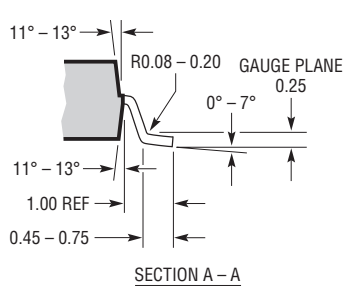
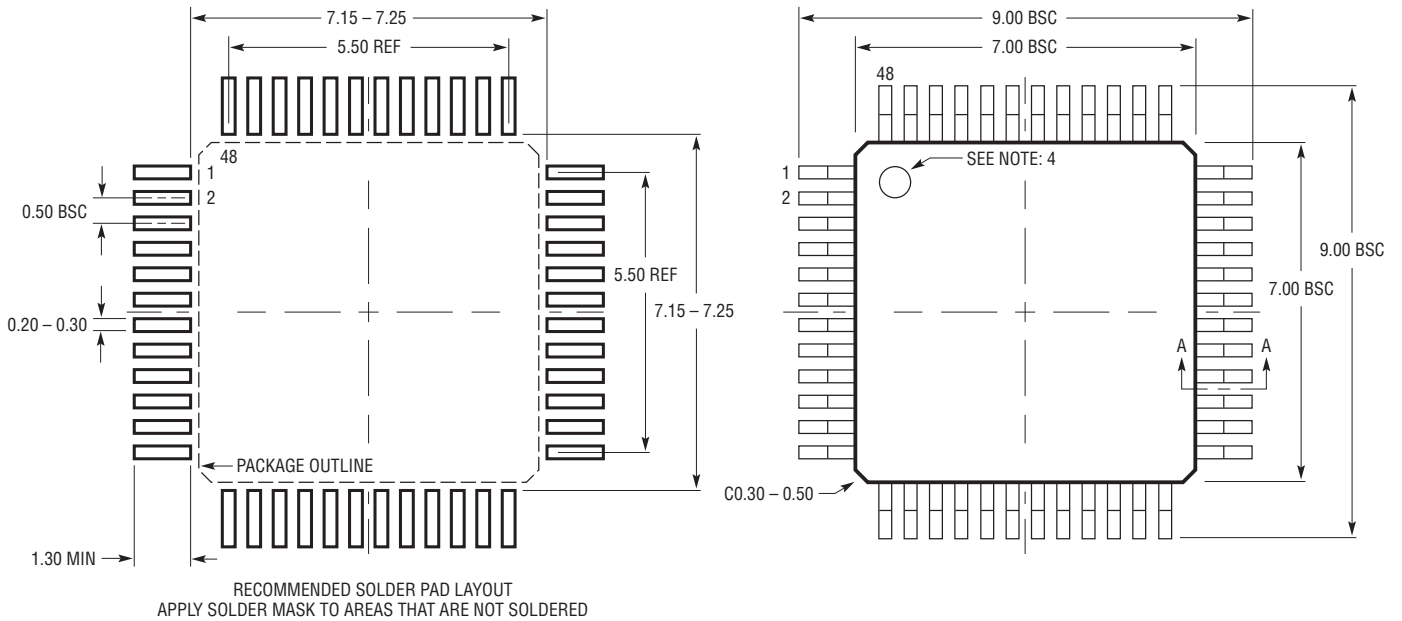

- NOTE:
1. PACKAGE DIMENSIONS CONFORM TO JEDEC #MS-026 PACKAGE OUTLINE
 2. DIMENSIONS ARE IN MILLIMETERS
 3. DIMENSIONS OF PACKAGE DO NOT INCLUDE MOLD FLASH. MOLD FLASH SHALL NOT EXCEED 0.25mm ON ANY SIDE, IF PRESENT
 4. PIN-1 IDENTIFIER IS A MOLDED INDENTATION, 0.50mm DIAMETER
 5. DRAWING IS NOT TO SCALE

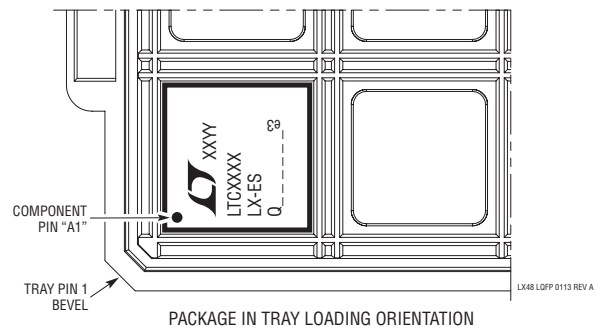

REVISION HISTORY

| REV | DATE | DESCRIPTION | PAGE NUMBER |
|-----|-------|---|---------------------------|
| A | 07/15 | Removed Tape and Reel options | 3 |
| | | Added Absolute Maximum Ratings for Q ₁ , Q ₂ , Q ₃ , LDO, V _{REFOUT} , V _{REF_BYP} | 3 |
| | | Changed reference Output Voltage Temperature Coefficient | 4 |
| | | Changed Error Contribution for thermocouples | 13 |
| | | Changed filter capacitor values in Figures 9, 12, 15, 18, 19, 21 | 33, 35, 37, 39, 40, 42 |

TYPICAL APPLICATION

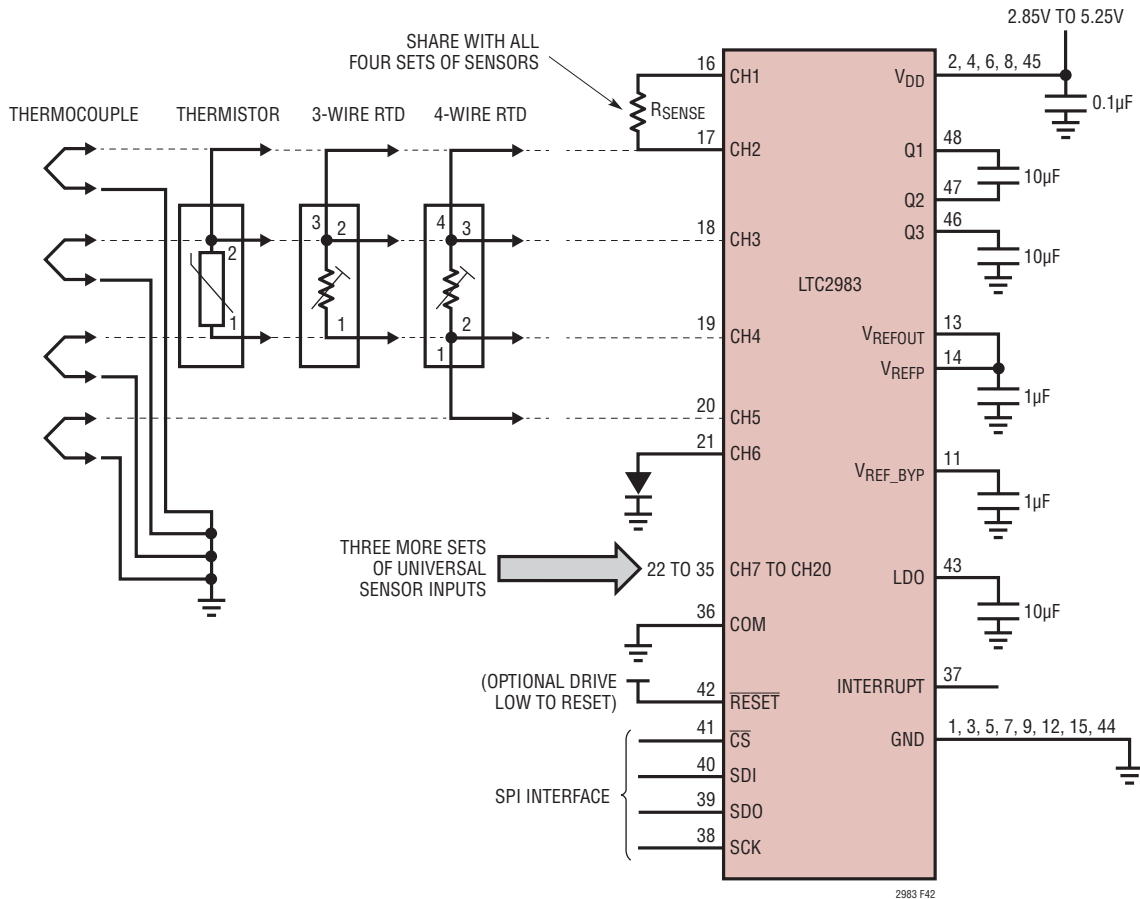

Figure 42. Universal Inputs Allow Common Hardware Sharing for Thermocouples, Diodes, Thermistors, 3-Wire RTDs, and 4-Wire RTDs

RELATED PARTS

| PART NUMBER | DESCRIPTION | COMMENTS |
|-------------------------|---|---|
| LTC2984 | Multi-Sensor High Accuracy Digital Temperature Measurement System with EEPROM | Pin/Software Compatible Version of LTC2983 with Integrated EEPROM |
| LTC2990 | Quad I ² C Temperature, Voltage and Current Monitor | Remote and Internal Temperatures, 14-Bit Voltages and Current, Internal 10ppm/°C Reference |
| LTC2991 | Octal I ² C Voltage, Current, Temperature Monitor | Remote and Internal Temperatures, 14-Bit Voltages and Current, Internal 10ppm/°C Reference |
| LTC2995 | Temperature Sensor and Voltage Monitor with Alert Outputs | Monitors Temperature and Two Voltages, Adjustable Thresholds, Open Drain Alert Outputs, Temperature to Voltage Output with Integrated 1.8V Reference, ±1°C (Max) Accuracy |
| LTC2996 | Temperature Sensor with Alert Outputs | Monitors Temperature, Adjustable Thresholds, Open Drain Alert Outputs, Temperature to Voltage Output with Integrated 1.8V Reference, ±1°C (Max) Accuracy |
| LTC2997 | Remote/Internal Temperature Sensor | Temperature to Voltage Output with Integrated 1.8V Reference, ±1°C (Max) Accuracy |
| LTC2943 | 20V I ² C Coulomb Counter | Monitors Charge, Current, Voltage and Temperature with 1% Accuracy. Works with Any Battery Chemistry and Capacity |

2983fa