

# DC Pass, High Power Dual-Directional Coupler

DDCH-35-252+

50  $\Omega$  36 dB Coupling 100W\* 225 to 2500 MHz

## The Big Deal

- Ultra wide band 225 to 2500 MHz (usable up to 3 GHz)
- High power handling, up to 100W
- Low insertion loss, 0.15 dB Typ.
- Excellent return loss, 26 dB Typ. (In-Out).

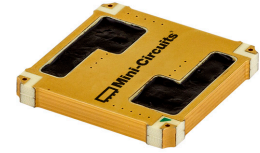

CASE STYLE: PQ2074-1

## Product Overview

Mini-Circuits DDCH-35-252+ is a high-power (100W), ultra wide band (225-3000MHz) dual-directional coupler which features low insertion loss (0.15 dB), 36 dB coupling and excellent mainline return loss(26 dB). The Dual directional design allows monitoring forward and reverse power and guarantees good directivity, flatness and coupling accuracy.

The DDCH-35-252+ supports a wide variety of applications from military to UHF radio (covering all UHF bands), various cellular base station applications and more.

The coupler is designed into an open printed laminate (1.0 x 1.0 x 0.128") with wrap-around terminations for good solderability and easy visual inspection.

## Key Features

Feature	Advantages
High power handling: 100W @ 85°C	Usable in many systems with high-power requirements such as antenna feeds, power amplifiers, and others that require sampling a high power RF signal.
Dual-Directional Coupler	Ideally suited for simultaneous monitoring of both forward and reverse power of a system, and reflectometer measurements. The Directivity is not affected by coupling ports mismatch.
Low insertion loss, 0.15 dB typ	Used primarily in high power transmission applications, the excellent through-path signal loss maximizes the power transmitted to the antenna.
Excellent return loss, 26 dB typ. (input and output)	Provides excellent matching for 50 $\Omega$ systems.
DC current passing, up to 2 A	Suitable for use in systems requiring DC voltage on the RF line, such as supplying bias to remote circuit via the antenna cable.



# DC Pass, High Power Dual-Directional Coupler

## DDCH-35-252+

50Ω 36 dB Coupling 100W\* 225 to 2500 MHz

### Maximum Ratings

Operating Temperature, case**	-55°C to 105°C
Storage Temperature	-55°C to 105°C
DC Current	2A
RF power *	100W @ +85°C, case

\*Derate to 80W at 95°C and 35W @ 105°C case temperature  
 \*\*Case temperature is defined as temperature on base plate.  
 Permanent damage may occur if any of these limits are exceeded.

### Pad Connections\*\*\*

INPUT	4
OUTPUT	2
COUPLED FORWARD	1
COUPLED REVERSE	3
GROUND	5

\*\*\*Model is Dual-directional input and output are interchangeable.

### Outline Drawing

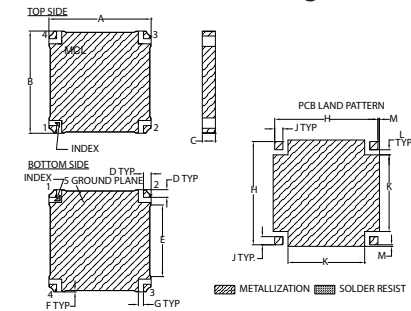

Base material: Printed wiring laminate.  
 Termination Finish: 2-5 μinch (0.05-0.13 microns) Gold over 120-240 μinch (3.05-6.10 microns) Nickel

### Outline Dimensions (inch/mm)

A	B	C	D	E	F	G
1.000	1.000	.128	.075	.700	.013	.050
25.40	25.40	3.25	1.90	17.78	0.33	1.27
H	J	K	L	M	wt.	
1.010	.080	.750	.050	.015	grams	
26.65	2.03	19.05	1.27	0.38	10.0	

Demo Board MCL P/N: TB-861  
 Suggested PCB Layout (PL-468)

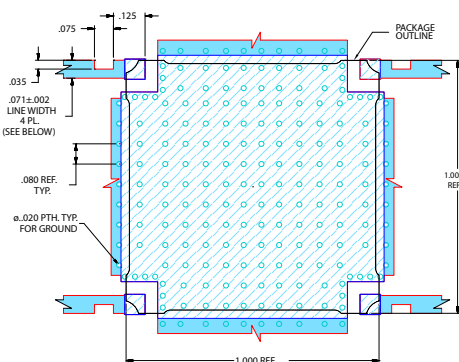

NOTES:  
 1. TRACE WIDTH IS SHOWN FOR ROGERS RO4003C WITH DIELECTRIC THICKNESS, 0.032 ± 0.015". COPPER: 1 OZ. EACH SIDE.  
 FOR OTHER MATERIALS TRACE WIDTH MAY NEED TO BE MODIFIED.  
 2. BOTTOM SIDE OF THE PCB IS CONTINUOUS GROUND PLANE.  
 3. CUTOUTS IN RF LINES ARE REQUIRED TO ACHIEVE SPECIFIED DIRECTIVITY.  
 ■ DENOTES PCB COPPER LAYOUT WITH SMOBC (SOLDER MASK OVER BARE COPPER)  
 ■ DENOTES COPPER LAND PATTERN FREE OF SOLDERMASK

### Features

- ultra wide band 225 to 2500 MHz (usable up to 3 GHz)
- high power, up to 100W
- low insertion loss, 0.15 dB typ.
- very good return loss, 26 dB typ
- DC current pass through input to output

### Applications

- UHF high power radio
- transmission signal monitoring
- simultaneous monitoring of forward and reverse power
- antenna reflection monitoring
- wireless transmitters
- distributed antenna systems (DAS)



CASE STYLE: PQ2074-1

### +RoHS Compliant

The +Suffix identifies RoHS Compliance. See our web site for RoHS Compliance methodologies and qualifications

### Electrical Specifications @ +25°C

Parameter	Condition (MHz)	Min.	Typ.	Max.	Units
Frequency Range		225		2500	MHz
Insertion Loss	225 - 2500	—	0.15	0.25	dB
Coupling	225 - 2500	—	36±1	—	dB
Coupling Flatness	225 - 2500	—	±0.6	—	dB
Directivity	225 - 2500	12	19	—	dB
Return Loss (Input)	225 - 2500	19	26	—	dB
Return Loss (Output)	225 - 2500	19	26	—	dB
Return Loss (Coupling)	225 - 2500	—	11	—	dB
Input RF Power	@ +85°C, case	225 - 2500	—	100	W
	@ +95°C, case	225 - 2500	—	80	
	@ +105°C, case	225 - 2500	—	35	

### Electrical Schematic

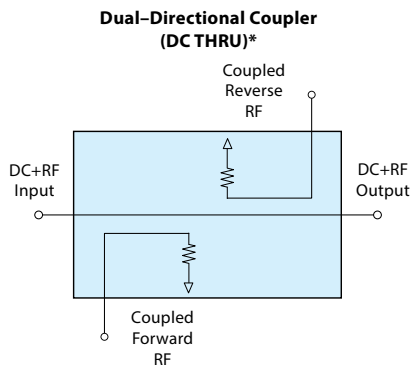

\*Mainline is DC coupled.

\*Coupling ports are DC coupled to internal terminations.



www.minicircuits.com P.O. Box 350166, Brooklyn, NY 11235-0003 (718) 934-4500 sales@minicircuits.com

REV. OR  
 M152372  
 EDR-11410/2  
 DDCH-35-252+  
 RAV  
 170716  
 Page 2 of 3

## Typical Performance Data \*

FREQUENCY (MHz)	Insertion Loss (dB)			Coupling (dB)		Directivity (dB)						Return Loss (dB)			
	In - Out			In -	Out -	In-Cpl Rev			Out-Cpl Fwd			In	Out	Cpl	Cpl
	-55°C	+25°C	+105°C	Cpl Fwd	Cpl Rev	-55°C	+25°C	+105°C	-55°C	+25°C	+105°C			Fwd	Rev
200.0	0.00	0.02	0.02	37.27	37.18	20.43	19.70	18.77	20.99	20.58	19.56	40.52	40.06	16.09	16.30
225.0	0.01	0.02	0.02	36.21	36.14	20.16	19.79	18.98	20.70	20.60	19.64	39.40	39.50	16.53	16.77
350.0	0.01	0.03	0.04	35.48	35.50	19.35	20.11	20.09	19.73	20.59	20.46	35.90	35.93	13.02	13.10
500.0	0.03	0.05	0.05	35.85	35.89	19.62	20.63	20.80	19.81	20.56	21.00	32.91	32.59	11.80	11.86
700.0	0.05	0.07	0.08	35.98	36.00	20.67	21.20	21.68	20.22	20.52	20.92	30.77	30.21	11.51	11.59
850.0	0.07	0.09	0.10	35.96	35.94	20.69	21.33	21.53	19.81	20.40	21.09	29.41	29.00	11.56	11.65
1000.0	0.09	0.10	0.11	35.92	35.88	20.21	21.32	21.57	19.65	20.11	20.43	28.80	28.62	11.69	11.75
1150.0	0.11	0.12	0.12	35.91	35.83	19.79	20.74	20.70	19.29	19.69	19.82	28.50	28.72	11.89	11.92
1300.0	0.12	0.13	0.13	35.90	35.78	19.36	19.97	19.03	19.28	19.28	19.22	28.53	29.03	12.11	12.09
1450.0	0.13	0.14	0.14	35.89	35.77	19.11	19.06	18.89	18.88	18.76	18.29	28.54	29.10	12.39	12.27
1600.0	0.12	0.15	0.14	35.89	35.76	18.74	18.16	17.60	18.18	18.28	18.76	28.60	28.87	12.66	12.42
1750.0	0.12	0.15	0.15	35.91	35.75	17.67	17.55	17.31	17.60	17.84	17.83	28.53	28.40	12.90	12.55
1900.0	0.12	0.16	0.16	35.96	35.74	16.92	17.19	16.92	17.25	17.49	17.14	28.72	27.81	12.98	12.55
2050.0	0.13	0.17	0.16	35.88	35.70	15.81	16.22	15.85	15.28	16.96	16.72	28.69	26.94	12.86	12.48
2200.0	0.14	0.18	0.17	35.85	35.66	13.88	14.96	14.71	14.90	15.94	15.96	28.42	26.20	12.44	12.23
2350.0	0.14	0.18	0.18	35.82	35.61	14.37	14.18	14.22	16.23	15.13	15.55	28.45	26.30	11.77	11.83
2500.0	0.16	0.18	0.17	35.90	35.63	13.43	13.43	12.85	14.60	14.45	15.17	29.32	26.96	10.96	11.25
2650.0	0.18	0.20	0.19	36.15	35.80	12.95	12.89	13.76	13.60	14.14	13.57	30.78	27.77	10.02	10.50
2700.0	0.17	0.18	0.18	36.28	35.90	11.75	12.80	13.31	13.32	14.01	13.27	31.83	28.38	9.68	10.23
2850.0	0.18	0.18	0.18	36.83	36.39	11.32	12.71	10.93	14.27	13.81	13.57	33.24	29.39	8.64	9.32
3000.0	0.15	0.17	0.17	37.51	37.01	12.16	12.67	12.80	13.49	13.78	15.66	33.34	30.03	7.73	8.48

\* Data at +25°C unless specified otherwise.

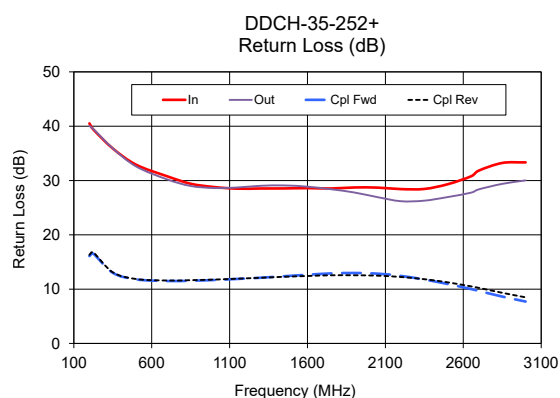
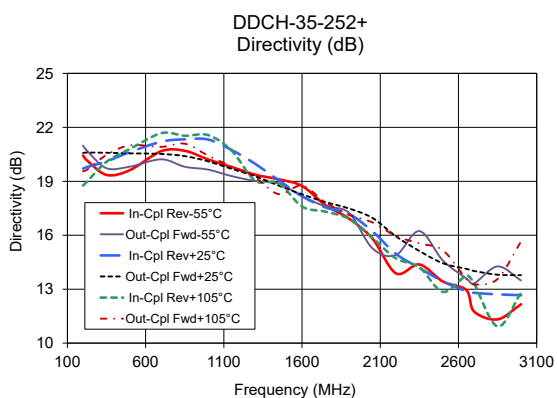
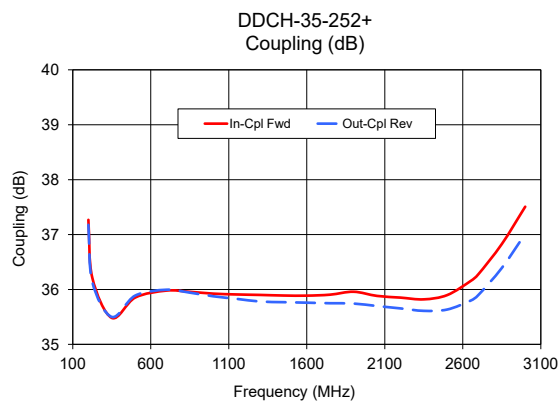
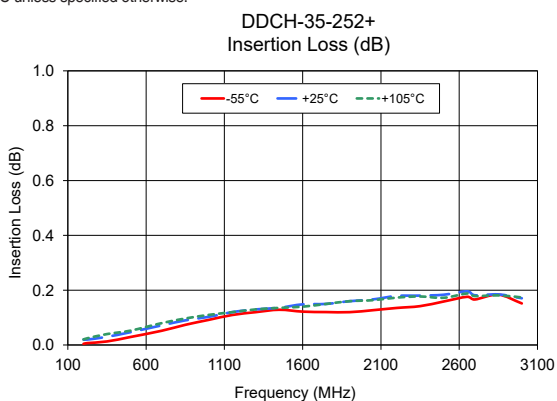

### Additional Notes

- Performance and quality attributes and conditions not expressly stated in this specification document are intended to be excluded and do not form a part of this specification document.
- Electrical specifications and performance data contained in this specification document are based on Mini-Circuits' applicable established test performance criteria and measurement instructions.
- The parts covered by this specification document are subject to Mini-Circuits standard limited warranty and terms and conditions (collectively, "Standard Terms"); Purchasers of this part are entitled to the rights and benefits contained therein. For a full statement of the Standard Terms and the exclusive rights and remedies thereunder, please visit Mini-Circuits' website at [www.minicircuits.com/MCLStore/terms.jsp](http://www.minicircuits.com/MCLStore/terms.jsp)