

# V-Link<sup>®</sup>-200

Wireless 8 Channel Analog Input Sensor Node

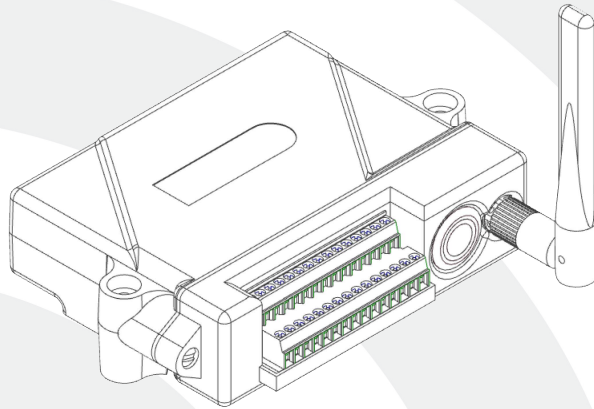



LORD Sensing Systems  
459 Hurricane Lane  
Suite 102  
Williston, VT 05495  
United States of America

**Phone:** 802-862-6629

**Fax:** 802-863-4093

9:00 AM to 5:00 PM (Eastern Time US & Canada)

<http://www.microstrain.com>  
[sensing\\_support@LORD.com](mailto:sensing_support@LORD.com)  
[sensing\\_sales@LORD.com](mailto:sensing_sales@LORD.com)

Document 8500-0063 Revision I

Subject to change without notice.

## Table of Contents

---

<b>1. Wireless Sensor Network Overview</b> .....	<b>6</b>
<b>2. Node Overview</b> .....	<b>7</b>
2.1 Components List .....	8
2.2 Interface and Indicators .....	9
2.3 Node Diagnostics .....	10
2.4 Node Operational Modes .....	13
<b>3. System Operation</b> .....	<b>14</b>
3.1 Software Installation .....	14
3.2 System Connections .....	15
3.3 Gateway Communication .....	16
3.4 Connect to Nodes .....	17
3.4.1 Automatic Node Discovery on Same Frequency .....	17
3.4.2 Automatic Node Discovery on Different Frequency .....	18
3.4.3 Manually Add Node .....	19
3.5 Configure Node .....	21
3.6 Configure and Start Sampling .....	23
<b>4. Viewing Data</b> .....	<b>26</b>
4.1 SensorConnect .....	26
4.1.1 Using Dashboards and Widgets .....	26
4.1.2 Navigating Graphs .....	26
4.1.3 Widgets Options .....	27
4.1.4 Time Series Widget Menu .....	27
4.1.5 Exporting Data Files .....	28
4.1.6 Navigating Menus .....	29
<b>5. Installation</b> .....	<b>32</b>
5.1 Mounting Recommendations .....	32

---

5.2	Optimizing the Radio Link .....	34
5.2.1	<i>Range Test</i> .....	35
<b>6.</b>	<b>Connecting Sensors</b> .....	<b>36</b>
6.1	Sensor Requirements .....	36
6.2	Wiring Recommendations .....	37
6.3	Sensor Power .....	38
6.4	Node Channels Designations .....	38
6.5	Terminal Block Connections .....	39
6.6	Pin Descriptions .....	40
6.7	Differential Input Channels .....	41
6.7.1	<i>Differential Sensors</i> .....	42
6.7.2	<i>Differential Channel Raw Voltage</i> .....	44
6.7.3	<i>Measuring Small Voltages</i> .....	45
6.8	Single-Ended Input Channels .....	46
6.8.1	<i>Measuring Small Currents (4 to 20mA Sensors)</i> .....	47
6.9	Using the Excitation Output as a Switch .....	48
6.10	Connecting Accelerometers .....	49
6.11	On-board Temperature Sensor .....	49
<b>7.</b>	<b>Sensor Settings</b> .....	<b>50</b>
7.1	Sensor Calibration .....	51
7.1.1	<i>EXAMPLE: Internal Shunt Calibration</i> .....	53
7.1.2	<i>Calibration Lab or Field</i> .....	56
7.1.3	<i>Manufacturer Calibration</i> .....	60
7.2	Sensor Conversion Values .....	61
7.2.1	<i>Calculating a Linear Slope</i> .....	65
7.2.2	<i>Differential Input Gain and Offset</i> .....	67



---

8.1	Powering the Node .....	69
8.2	Using the Internal Node Battery .....	69
8.3	Connecting an External Power Supply .....	70
<b>9.</b>	<b>Troubleshooting .....</b>	<b>71</b>
9.1	Troubleshooting Guide .....	71
9.2	Using the Node Tester Board .....	75
9.3	Updating Node Firmware .....	79
9.4	Repair and Calibration .....	81
9.5	Maintenance .....	82
<b>10.</b>	<b>Wireless Equipment .....</b>	<b>83</b>
10.1	Standard Nodes .....	83
10.2	Node Accessories .....	83
10.3	Recommended Sensors .....	84
10.4	Wireless System Equipment .....	85
<b>11.</b>	<b>Specifications .....</b>	<b>87</b>
11.1	Physical Specifications .....	87
11.2	Operating Specifications .....	88
11.3	Radio Specifications .....	89
11.4	Frequency Setting .....	89
<b>12.</b>	<b>Safety Information .....</b>	<b>91</b>
12.1	Replacing Batteries .....	91
12.2	Battery Hazards .....	91
12.3	Power Supply .....	92
12.4	Disposal and Recycling .....	92
<b>13.</b>	<b>References .....</b>	<b>93</b>
13.1	Related Documents .....	93
<b>14.</b>	<b>Glossary .....</b>	<b>94</b>

## 1. Wireless Sensor Network Overview

The LORD Sensing Wireless Sensor Network is a high-speed, scalable, sensor data acquisition and sensor networking system. Each system consists of wireless sensor interface nodes, a data collection gateway, and full-featured user software platforms based on the LORD Sensing Lossless Extended Range Synchronized (LXRS) and data communications protocols. Bi-directional wireless communication between the node and gateway enables sensor data collection and configuration. Gateways can be connected locally to a host computer or remotely via local and mobile networks. Some gateways also feature analog outputs for porting sensor data directly to stand-alone data acquisition equipment.



The selection of available nodes allows interface with many types of sensors, including accelerometers, strain gauges, pressure transducers, load cells, torque and vibration sensors, magnetometers, 4 to 20 mA sensors, thermocouples, RTD sensors, soil moisture and humidity sensors, inclinometers, and orientation and displacement sensors. Some nodes come with integrated sensing devices such as accelerometers. System sampling capabilities include lossless synchronized sampling, continuous and periodic burst sampling, and data logging. A single gateway can coordinate many nodes of any type, and multiple gateways can be managed from one computer with the SensorConnect™ and SensorCloud™ software platforms. Integration to customer systems can be accomplished using OEM versions of the sensor nodes and leveraging the LORD Sensing data communications protocol.

Common wireless applications of LORD Sensing Sensing Systems are strain sensor measurement, accelerometer platforms, vibration monitoring, energy monitoring, environmental monitoring, and temperature monitoring.

## 2. Node Overview

The V-Link-200 wireless sensor node features eight analog input channels designed to accommodate a wide range of Wheatstone bridge and analog sensors, including strain, load cell, torque, pressure, acceleration, vibration, magnetic field, displacement, and geophones. There are four channels for single-ended sensor measurement, four channels for differential sensor measurement, and an on-board internal temperature sensor.

V-Link-200 inputs are 18-bit resolution with  $\pm 0.1\%$  full scale measurement accuracy. The node can log data to internal memory, transmit real-time synchronized data, and it supports event driven triggers with both pre- and post- event buffers.

To acquire sensor data, the V-Link-200 is used with a LORD Sensing WSDA gateway, and comes with the following configuration options.



Figure 1 - V-Link-200

## 2.1 Components List

V-Link-200 sensor node comes with the following configuration options. For a complete list of available configurations, accessories, additional system products and ordering information, [see Wireless Equipment on page 83](#).

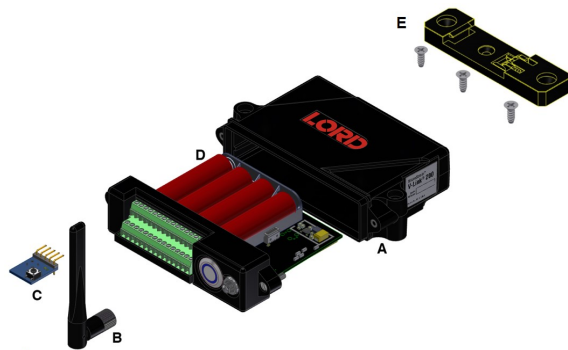

Item	Description	Quantity
A	V-Link-200	1
B	Antenna with right angle adapter	1
C	Node tester board	1
D	AA Lithium batteries (3.6 V dc, 2.4 Ah)	4
E	DIN rail clip	1
	#6-32 x 3/8" Thread forming screws	3
--	Calibration Certificate	1

## 2.2 Interface and Indicators

The V-Link-200 LEDs indicate operational modes showing when the node is booting up, idle and waiting for a command, sampling, resynchronizing, or if there is an error.

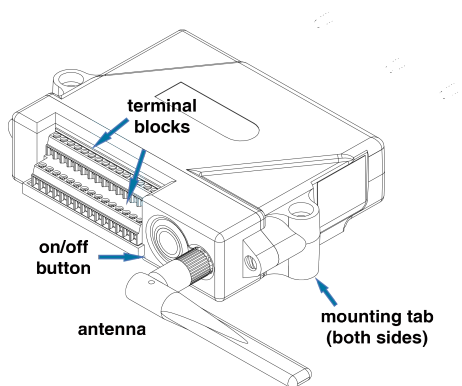

Figure 2 - Interface and Indicators

Indicator	Behavior	Node Status
Device status indicator	OFF	Node is OFF
	Rapid green flashing on start-up	Node is booting up
	1 (slow) green pulse per second	Node is idle and waiting for a command
	1 green blink every 2 seconds	Node is sampling
	Blue LED during sampling	Node is resynchronizing
	Red LED	Built-in test error

Table 1 - Indicator Behaviors

## 2.3 Node Diagnostics

In the Wireless Node Configuration menu under the Sampling tab, there are four user-set data points to provide information about the status of the Node.

The screenshot shows the 'Wireless Node Configuration' menu with the 'Sampling' tab selected. The settings are as follows:

Setting	Value	Unit
Lost Beacon Timeout	Off	0 minute(s)
Diagnostic Info Interval	On	30 second(s)
Storage Limit Mode	Stop	
Sensor Warmup Delay	1	μsec(s)

Additional options:  Sensor Always On

Apply Configuration

Figure 3 - Node Diagnostic Menu

- **Lost Beacon Timeout:** The time a node will search for a beacon before determining there is no base station connectivity. User-set between 2 minutes and 600 minutes
- **Diagnostic Info Interval:** The report rate of the diagnostic packet. User-set between 30 seconds and 65536 seconds. The following data channels are available.
  - **Current State:** The current state of the device when the Diagnostic Packet is sent.
    - 0 = Idle
    - 1 = Deep Sleep
    - 2 = Active Run
    - 3 = Inactive Run
  - **Run Time:** The number of seconds the Node has been in each state.
  - **Reset Counter:** The number of times the Node has reset.
  - **Low Battery Indicator:** If 1, a low battery event has been detected since the last Diagnostic Packet.
  - **Sample Info:**
    - **Sweep Index:** The total number of sweeps (good and bad).

- **Bad Sweep Count:** The total number of failed sweeps.
- **Transmit Info:**
  - **Total Transmissions:** Number of unique packets transmitted (not including retransmissions.)
  - **Total Retransmissions:** Number of retransmitted packets. Packets are retransmitted when a node does not receive acknowledgment from the base station.
  - **Total Dropped Packets:** Number of packets the Node has discarded due to buffer overflow, or exceeding the maximum number of retransmissions per packet.
- **Built in Test Result:** The result of the Built in Test function.
- **Event Trigger Index:** The index of the most recent Event Trigger logged to the Node. When this number changes, a new event has occurred.
- **External Power:** Flag indicating if external power is connected or not.
  - 0 = Not Connected
  - 1 = External Power Connected
- **Internal Temperature:** The internal temperature of the Node in degrees Celsius.
- **Storage Limit Mode:** Determines the behavior of the storage as either first in, first out (FIFO), or stops when the storage is full. Set at Stop by default with an Overwrite option in the drop down menu
- **Sensor Warm Up Delay:** The delay time before sampling after excitation is enabled. Sensor Always On is set by default and indicated by a check mark. To manually set this feature, uncheck the box and set between 1 μsecond and 66000 μseconds.

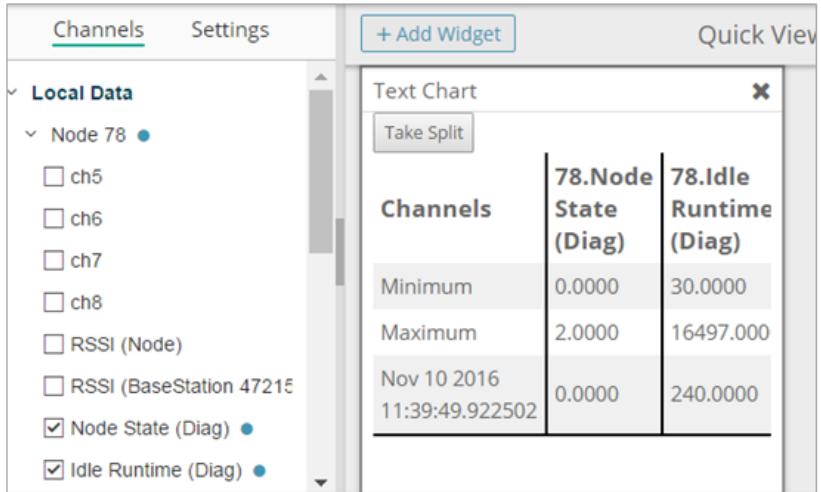

Figure 4 - Viewing Node Diagnostic Data



## 2.4 Node Operational Modes

Sensor nodes have three operational modes: *active*, *sleep*, and *idle*. When the node is sampling, it is in active mode. When sampling stops, the node is switched into idle mode, which is used for configuring node settings, and allows toggling between sampling and sleeping modes. The node will automatically go into the ultra low-power sleep mode after a user-determined period of inactivity. The node will not go into sleep mode while sampling.

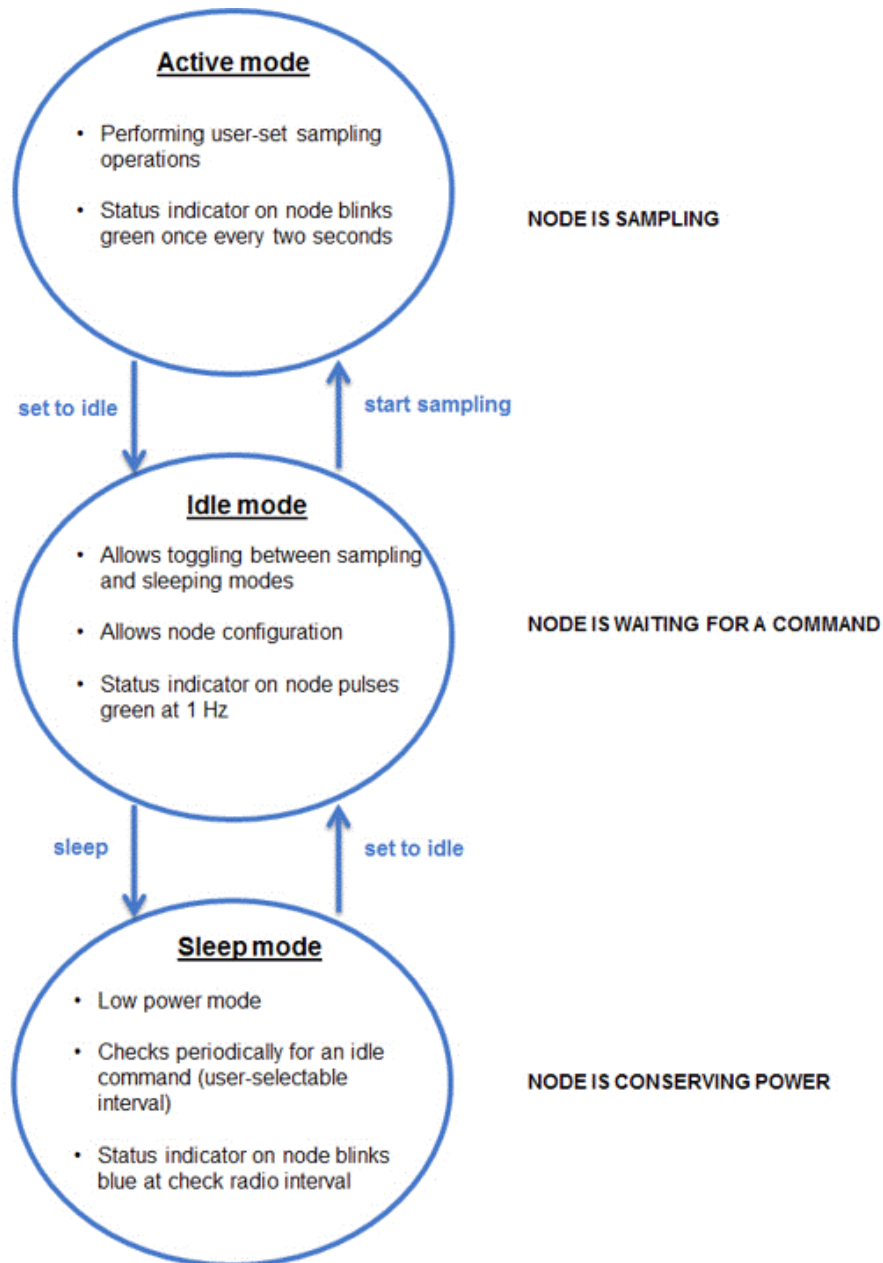

Figure 5 - Node Operational Modes

### 3. System Operation

LORD Sensing has two software programs available for data acquisition from the wireless sensor network: SensorCloud and SensorConnect. SensorCloud is an optional web-based data collection, visualization, analysis, and remote management platform based on cloud computing technology. SensorConnect is PC-based software used for configuring gateways and nodes, selecting sampling modes and parameters, initializing data acquisition, and viewing and saving data.

#### 3.1 Software Installation

Install the **SensorConnect** software on the host computer before connecting any hardware. Access the free software download on the LORD Sensing website at:



<http://www.microstrain.com/software>

**SensorCloud** is an optional data collection, visualization, analysis, and remote management tool. It is based on cloud computing technology and is accessed directly from a web connection. For more information go to: <http://www.sensorcloud.com/>.



### 3.2 System Connections

To acquire sensor data the following components are needed: a LORD Sensing wireless sensor node, a LORD Sensing data gateway, and a host computer with access to the data acquisition software.

The sensor, node, gateway, and software selection are application-dependent, but the basic interfaces are the same. The V-Link-200 gateway utilizes Ethernet communications and can be used with SensorConnect and SensorCloud™, although system configuration is completed using SensorConnect.

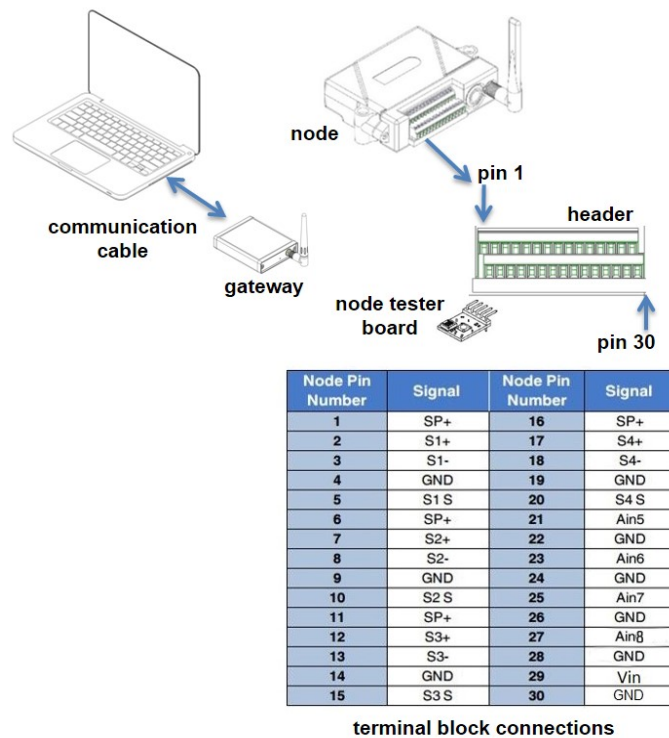

Figure 6 - System Connections

### 3.3 Gateway Communication

Drivers for the USB gateways are included the SensorConnect software installation. With the software installed, the USB gateway will be detected automatically whenever the gateway is plugged in.

1. Power is applied to the gateway through the USB connection. Verify the gateway status indicator is illuminated, showing the gateway is connected and powered on.
2. Open the SensorConnect™ software.
3. The gateway should appear in the Controller window automatically with a communication port assignment. If the gateway is not automatically discovered, verify the port is active on the host computer, and then remove and re-insert the USB connector.

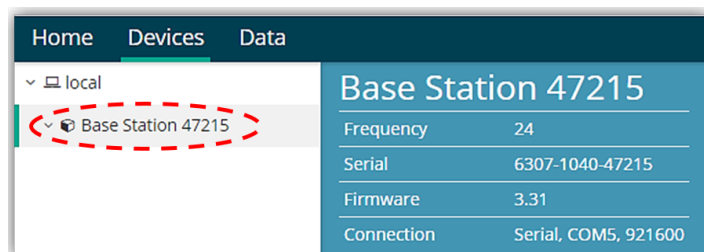

Figure 7 - USB Gateway Communication

### 3.4 Connect to Nodes

Several methods can be used in SensorConnect to establish communication with the nodes: the automatic node discovery on the same frequency, automatic node discovery on a different frequency, and add node manually.

#### 3.4.1 Automatic Node Discovery on Same Frequency

If the base and node are on the same operating frequency, the node will populate below the Base Station listing when powering on the V-Link-200.

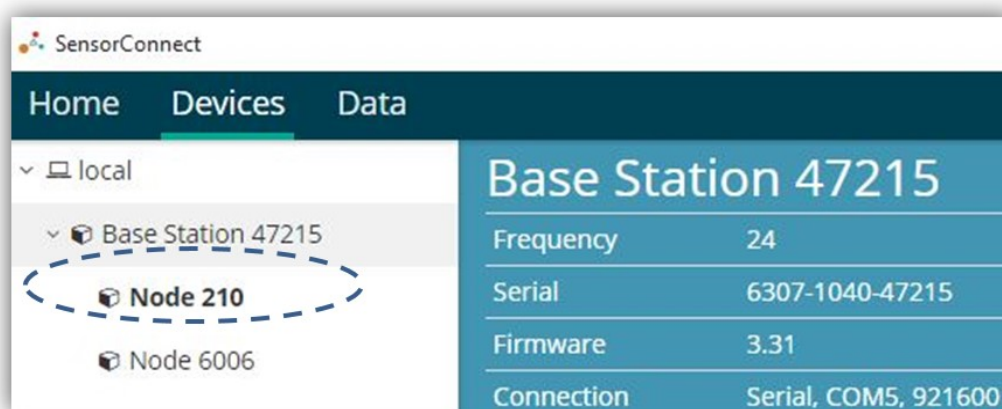

Figure 8 - Node Discovered On Same Frequency

### 3.4.2 Automatic Node Discovery on Different Frequency

If a red circle with a number appears next to the Base Station, the node is operating on a separate radio channel. Select the Base Station and then select the Nodes on Other Frequencies tile.

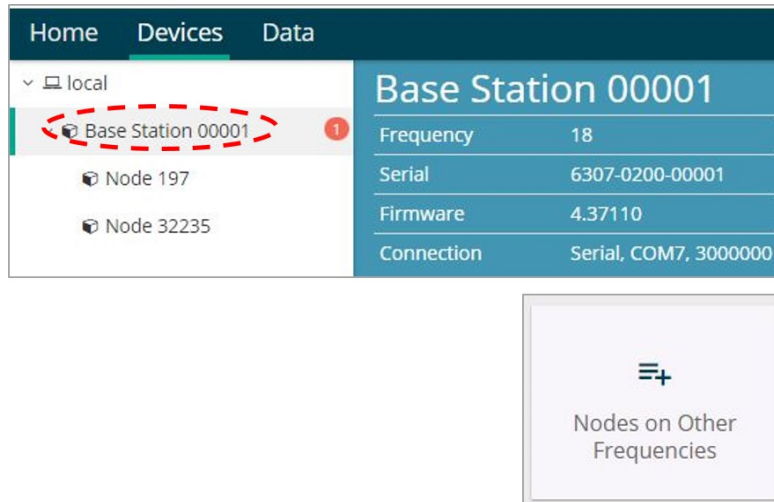

Figure 9 - Node On Other Frequency

Highlight the new node being added and select Move Node to Frequency (#).

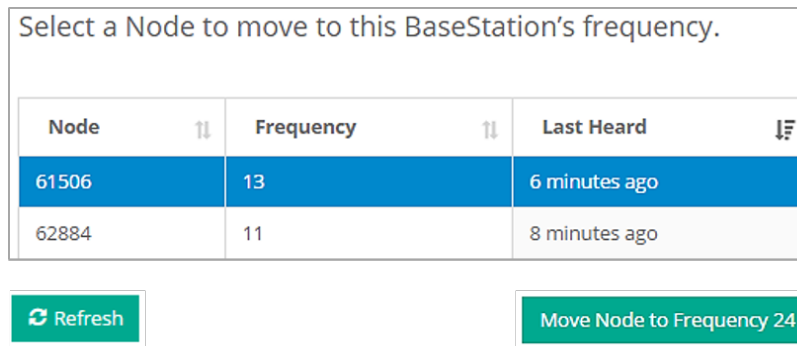

Figure 10 - Move Node

### 3.4.3 Manually Add Node

Adding a node manually requires entering the node address and its current frequency setting.

From the Base Station, select the Manual Add Node tile, enter the Node Address, last known Frequency (factory default is 15), and select Add Node.

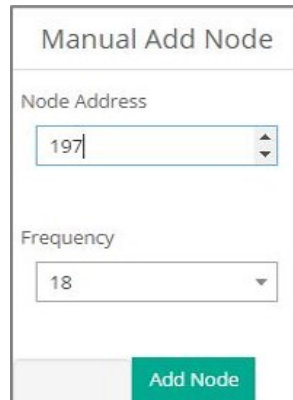

Figure 11 - Add Node By Address

If the node was successfully added, two confirmation messages will appear and it will be listed under the Base Station.

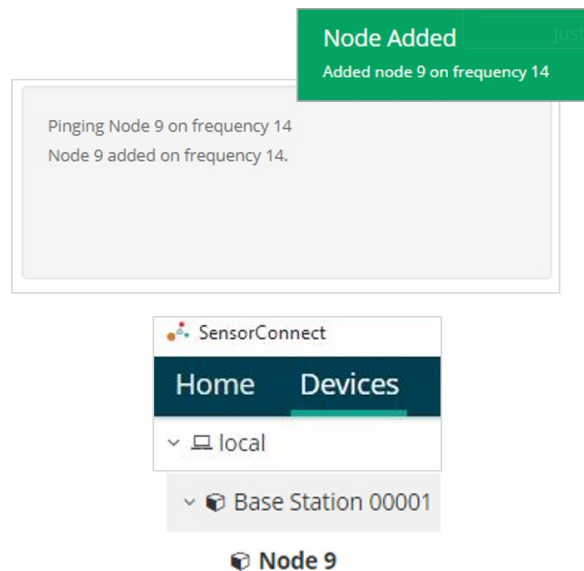

Figure 12 - Add Node Confirmation

If the node failed to be added, a failure message will appear. This means the node did not respond to the base station which could indicate the node is not in idle mode or it may be on another frequency. If "Add Node Anyway" is selected, it will associate that node with the channel entered but it is likely there will be a communication error. If the node was not in idle, move the base station to the frequency of the node and issue a "Set to Idle" command.

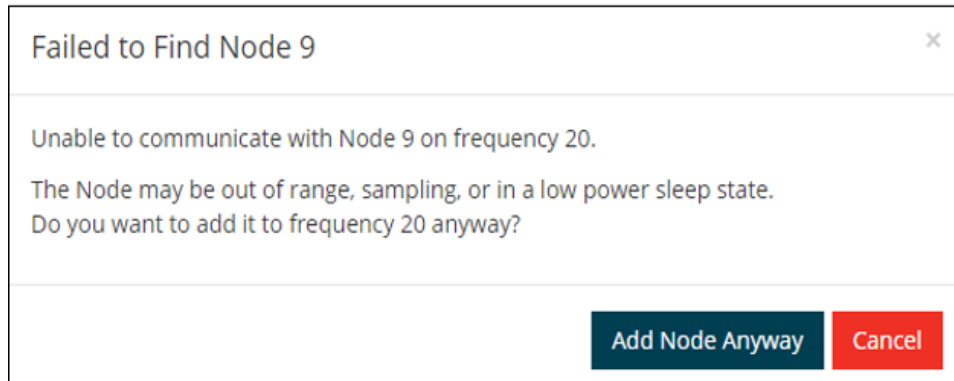
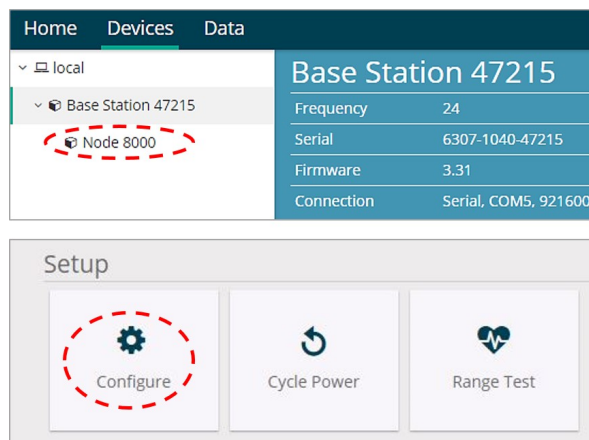

Figure 13 - Failure to Add Node



### 3.5 Configure Node

Node settings are stored to non-volatile memory and may be configured using SensorConnect. To access the node configuration menu, under Devices select the node and then the Configure tile.



The configuration menus show the channels and configuration options available for the type of node being used.

For this example the V-Link-200 tester board is on channel 1.

1. Select Hardware > Input Range for channel 1, select +/-2 mV from the drop down menu.
2. Under Hardware Offset, select Balance Target for channel 1, select Mid (50%) from the drop down menu.
3. Select Auto-Balance. When auto-balance is complete, a blue information window will indicate the balance result.

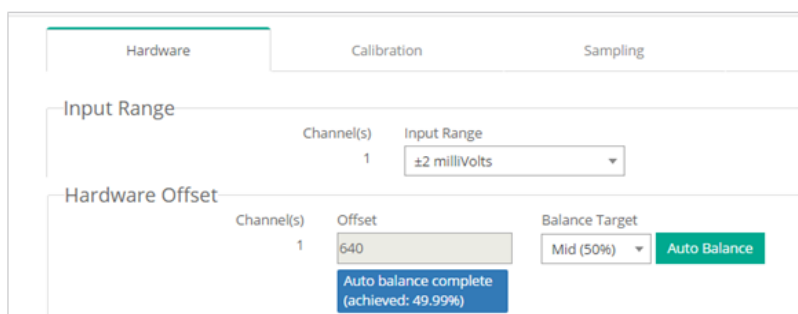

Figure 14 - Auto-Balance

4. Select Calibration.
5. Select Microstrain from the Unit drop down menu, and select the Shunt Cal button enabled on the right.

Channel(s)	Slope	Offset	Unit
1	1	0	Microstrain

Figure 15 - Node Configuration Menu

6. Use the following settings:
  - a. **Calibration Mode:** Internal
  - b. **Number of Active Gauges:** 4
  - c. **Gauge Factor:** 2
  - d. **Gauge Resistance:** 1000
  - e. **Shunt Resistance:** 499000
7. Select Start Shunt Cal for Slope and Offset calibrations.
8. Select Accept Calibration.

Shunt Calibration

Node: 78 - Channel: ch1

Calibration Mode	Internal
# Active Gauges	4
Gauge Factor	2
Gauge Resistance	1000 ohm
Shunt Resistance	499000 ohm
Simulated Strain	250

Start Shunt Cal

Figure 16 - Channel Settings

9. When the calibration is complete, the Wireless Node Configuration window will appear.
10. Select Apply Configuration to write to node memory.

### 3.6 Configure and Start Sampling

To start a sampling session, nodes can be selected individually by selecting the Node name and then the Sample tile.

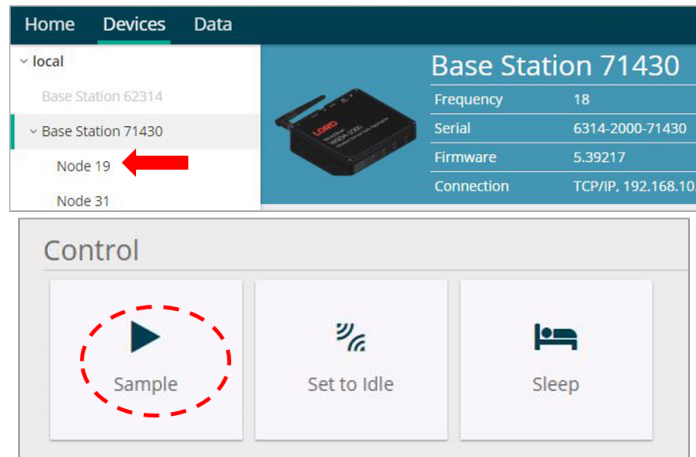

To sample multiple nodes as a group, select the Base Station and then the Sampling Network tile.

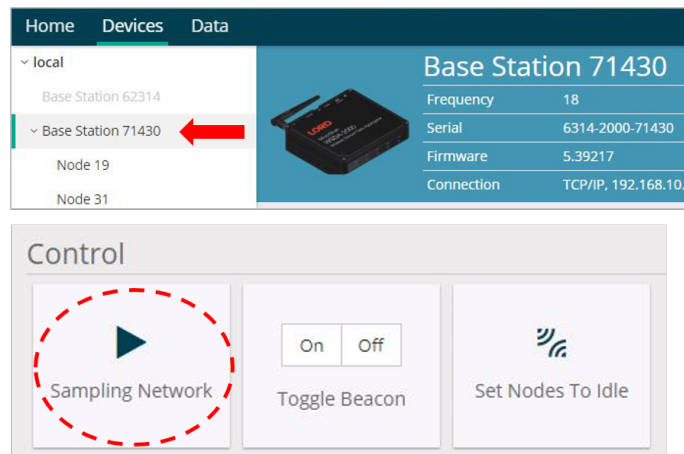

As a group, they will all be set to the same sampling mode. When the Base Station is selected, all the nodes will appear in a list with a check mark to the left, all of the nodes checked off will be included in the sampling. Uncheck the nodes to be excluded from the sampling.

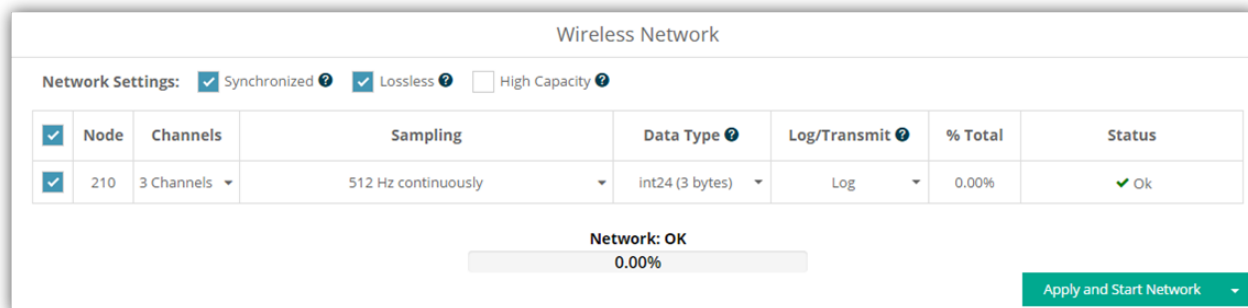

Figure 17 - Network and Node Configuration Menu

- **Synchronized** - By selecting Synchronized, all nodes in the network will periodically synchronize their time clocks to a beacon that is broadcasted by the **WSDA gateway**. Each beacon contains a UTC timestamp, allowing nodes to timestamp their collected data within an accuracy of +/- 50 us.

Each node will also buffer data and transmit this data in time-slots allocated prior to sampling. Using time-slots assures the transmissions will not “collide”, or corrupt each other. It also provides a means for efficiently scaling the size of the network to allow as much data throughput as possible.

If Synchronized is deselected, the node will not require a beacon time source and will transmit a data transmission for each measurement sweep. The user should deselect Synchronized if, either low latency, or the lowest possible power at slow sample rates, is required.

- **Lossless** - The user can achieve near lossless data collection in most environments through the use of data buffering, radio acknowledgments, and retransmissions. Each node buffers collected data and timestamps to an internal 2 Mbit FIFO buffer. For each transmission, data is pulled from this buffer. Upon receiving the data packet, an acknowledgment is sent from the **WSDA gateway** providing the beacon. The node will retransmit data until this acknowledgment is received. Inherent overhead in the transmission scheduling protocol assures the node time to recover from periods of poor radio communication.

This feature allows lossless performance in environments where the node achieves as low as 50% packet error rate. It also allows for operation in situations where the gateway and node move in and out of range of each other.

**NOTE:** The Lossless feature is only available when Synchronized is enabled. Disable Lossless if the application requires consistent latency or can tolerate lost data.

- **Node:** Indicates the node address beside a box with a check mark. This box is checked by default to include the node in the sampling. Uncheck the box to exclude the node from the sampling.
- **Channels:** Provides a drop-down menu to select the desired sensor channels for the node.
- **Sampling:** Displays a drop-down menu to select the sample rate. "Continuously" samples indefinitely, "For" specifies a fixed sampling time-frame, and "Bursting" allows short sampling durations performed at periodic intervals.
- **Data Type:** Select the resolution of the data reported by the node. Selecting lower resolution data will require fewer transmissions and lower power. Selecting "Float" will request the node send data in the configured calibration unit type.
- **Log/Transmit:** Select "Log Only" to have the node store all collected data to flash memory for later download. Select "Transmit Only" to have the node transmit all data while it is collected. Or select "Log and Transmit" to have the node perform both operations.
- **% Total:** Indicates the percentage of total over-the-air bandwidth reserved for each node.
- **Status:** Displays network errors.
- **Apply and Start Network:** Applies all of the settings, starts the entire network, and starts the Base Station's beacon.
  - **Apply and Arm Nodes:** This setting allows the user to Arm all of the nodes without starting the beacon. If the gateway has already enabled the beacon, this setting will keep the gateway's beacon.
  - **Apply Only:** Saves the settings to memory and not start the network.

## 4. Viewing Data

### 4.1 SensorConnect

#### 4.1.1 Using Dashboards and Widgets

Collected data is viewed on the Data page through the creation of dashboards and widgets. Think of dashboards as individual pages and widgets as an illustration on the page. Create multiple data widgets on each dashboard to display sampled data as a time-series graph, text chart, or a simple gauge that only displays the most current reading. This format provides an easy way to organize many sensors and networks, and it allows the information to be displayed in the most appropriate layout.

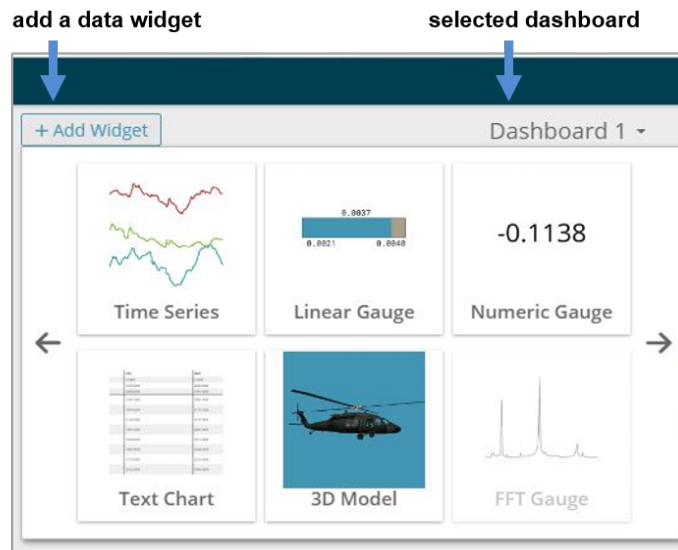

Figure 18 - Viewing Data

#### 4.1.2 Navigating Graphs

Use the mouse along with the shift and control keys inside the graph window to adjust the data view.

Control	Action
Mouse wheel	Zoom in/out on x-axis
Shift + mouse wheel	Zoom in/out on y-axis
Mouse double-click	Zoom to extends
Shift + mouse left-click, drag left/right	Zoom window left/right
Shift + mouse left-click, drag up/down	Zoom window up/down
Ctrl + mouse left-click, drag	Zoom box

Table 2 - Graph View Controls

### 4.1.3 Widgets Options

The widget configuration menu is different for each type of widget but typically includes sensor or channel selections and widget settings such as titles and legends.

After adding a widget, left click to select and configure it in the Channels and Settings left sidebar menu. Under Channels, the channel(s) for the widget can be enabled and disabled.

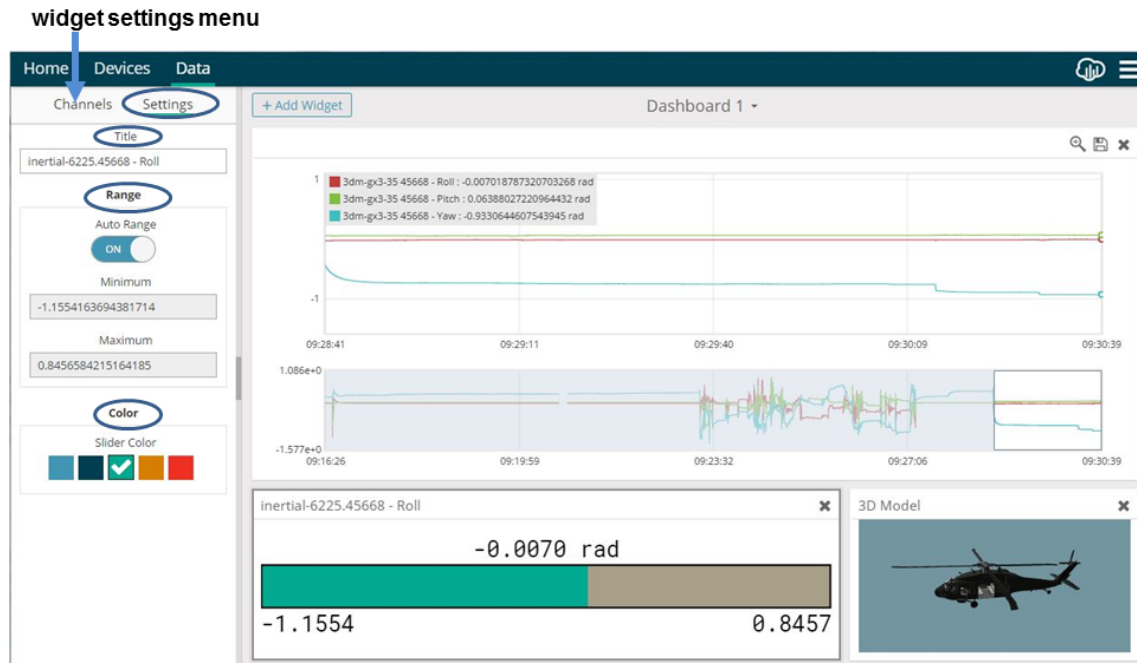

Figure 19 - Widget Settings Menu

### 4.1.4 Time Series Widget Menu

The Time Series Widget menu has two features to help optimize sensor data collection for export to a .csv file. *Snap to Latest* captures the most recent data and *Zoom* isolates specific events from a larger data sample (see [Exporting Data Files on page 28](#)).



Figure 20 - Time Series Widget Menu

### 4.1.5 Exporting Data Files

To export data to a .csv file, select the Export Data button on the Time Series widget > Export > name the document > save to the preferred location on the host computer.

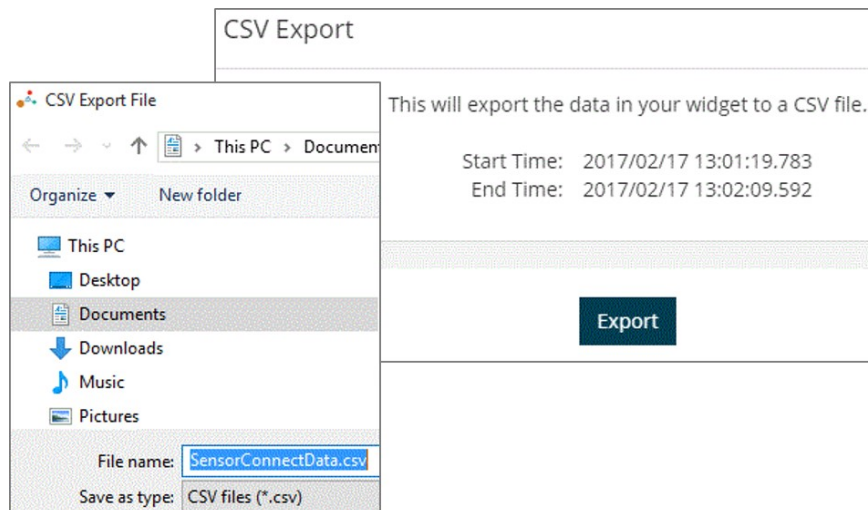

Figure 21 - Exporting Data

Data acquired through SensorConnect is automatically saved on the host computer. Saved data can be uploaded to SensorCloud. Ethernet gateways provide the option to automatically port the data to SensorCloud during data acquisition for near real-time display and aggregation. Ethernet gateways can also be configured to save data locally to internal memory for future upload to the host computer or SensorCloud.

SensorCloud is based on cloud computing technology and is designed for long term collecting and preservation of data. Features include time series and visualization graphing, automated alerts, and data interpretation tools such as data filtering, statistical analysis, and advanced algorithm development with the integrated MathEngine<sup>®</sup> interface. Leveraging the open source API, SensorCloud can also be used to collect data from other LORD Sensing sensor products or third-party systems. Basic SensorCloud services are available to all users free of charge at: <http://www.sensorcloud.com/>.

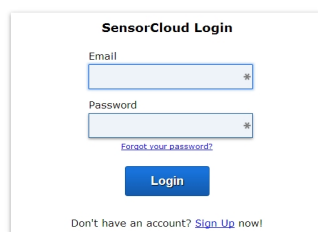

Figure 22 - SensorCloud Log-in or Register



### 4.1.6 Navigating Menus

The SensorCloud interface has **six main views**. When logging in as a registered user, the Device view is the default. Navigate to other views by clicking the view name at the top of the page (*Figure 23 - SensorCloud Menu Views*). The Data and Settings views are only available once a device is selected from the device list.

The screenshot shows the SensorCloud interface with a navigation menu at the top. The menu items are: DEVICES, ACCOUNT, CSV UPLOADER, DATA, SETTINGS, and MATHENGINE. A callout box points to the 'DEVICES' menu item with the text: "Device lists - select a device to access Data and Settings menus". Below the menu, there are three sections: Owned Devices, Shared Devices, and Demo Devices, each with a table of device information.

Owned Devices					
DEVICE	PLAN	CONFIGURATION	LAST HEARD FROM	DATA (JUN 18 - JUL 18) USAGE	TOTAL STORAGE
New Device OAF102350CH709H	Basic <b>UNLOCKED</b>	Configuration		Transactions: 0.00K/25K Monthly Storage: 0.00/10 MDP	0.00 MDP
W063140205021034	Basic <b>UNLOCKED</b>	Configuration	7/21/14 11:30	Transactions: 0.00K/25K Monthly Storage: 0.00/10 MDP	1.88 MDP

Below the Owned Devices table is an "Add Device" button.

Shared Devices			
DEVICE	CONFIGURATION	LAST HEARD FROM	
MSTest (andy) FFFF015C91C7480	Configuration	7/15/15 12:02	
CallFrac - Heavy Loading Run Up 9-4-13 OAF55CC595K4URZ	Configuration		

Demo Devices	
DEVICE	LAST HEARD FROM
Demo Structure OAF0339T2K5FD4X	7/14/15 14:36

Figure 23 - SensorCloud Menu Views

**Device** - The device list shows every Ethernet gateway and API device associated with the SensorCloud account, including owned, shared, and demo devices. This view provides links to each device's SensorCloud subscription plan, configuration options, and a summary of last communications and data transactions.

**Account** - The account view is for logistic management of the SensorCloud account, such as changing the log-in password, accessing user email, and reviewing billing information.

**CSV Uploader** - The data upload feature enables data from any source (such as non-Ethernet LORD Sensing gateways, or third-party sensor) to be uploaded to the SensorCloud platform. The data must be in the LORD Sensing CSV format.

**Data** - This view is only available after a device is selected. It displays data that is collected from sensor nodes or uploaded from files. Data selections are listed by node channel or a user-defined label and can be enabled for display in the graph window. The interactive graph has navigational features such

as panning, zooming, and an overview graph for single-click access to data points or ranges. There are also use and management features such as viewing the meta-data and downloading, embedding, and tagging data graphs.



Figure 24 - SensorCloud Data View

**Settings** - The settings view provides options for adding meta-data, configuring the data displays for each channel, creating alerts based on data thresholds, setting the data timezone, and more.

**MathEngine<sup>®</sup>** - is used to analyze sensor data. Functions include the ability to filter out frequencies, smooth out noisy data, perform math operations such as Fast Fourier Transforms (FFTs), and more (*Figure 25 - MathEngine<sup>®</sup> View*). MathEngine<sup>®</sup> interfaces with the SensorCloud graphing view for faster processing. Users can write their own algorithms for custom applications. Refer to the MathEngine<sup>®</sup> website for more information.

<http://sensorcloud.com/mathengine>

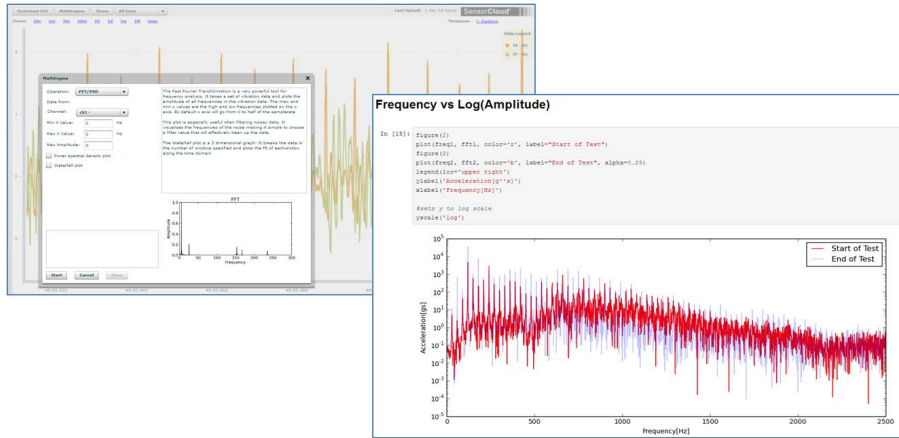

Figure 25 - MathEngine<sup>®</sup> View

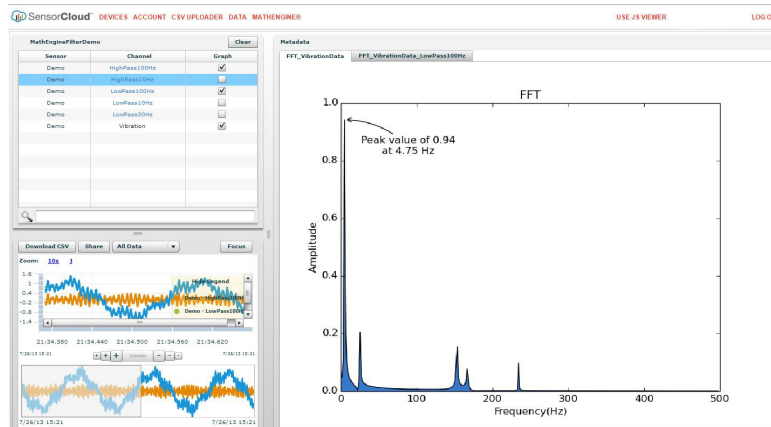

Figure 26 - FFT Graph in SensorCloud

For more information about SensorCloud features and navigation, refer to the SensorCloud website: <http://www.sensorcloud.com/>, or contact LORD Sensing Technical Support.

## 5. Installation

### 5.1 Mounting Recommendations

The V-Link-200 is rated for indoor use only, unless housed in a ruggedized outdoor enclosure. Enclosures for the V-Link-200 are available from LORD Sensing.

There are two mounting tabs on the node, with holes for fastening. A DIN rail clip and three screws are included with the V-Link-200 for optional DIN rail mounting ([Figure 29 - DIN Rail Mount Option](#)).

The node can be mounted in any orientation, but it is recommended that it is mounted in a way that optimizes wireless communications, typically with the antenna pointing upward. For more information, [see Optimizing the Radio Link on page 34](#).

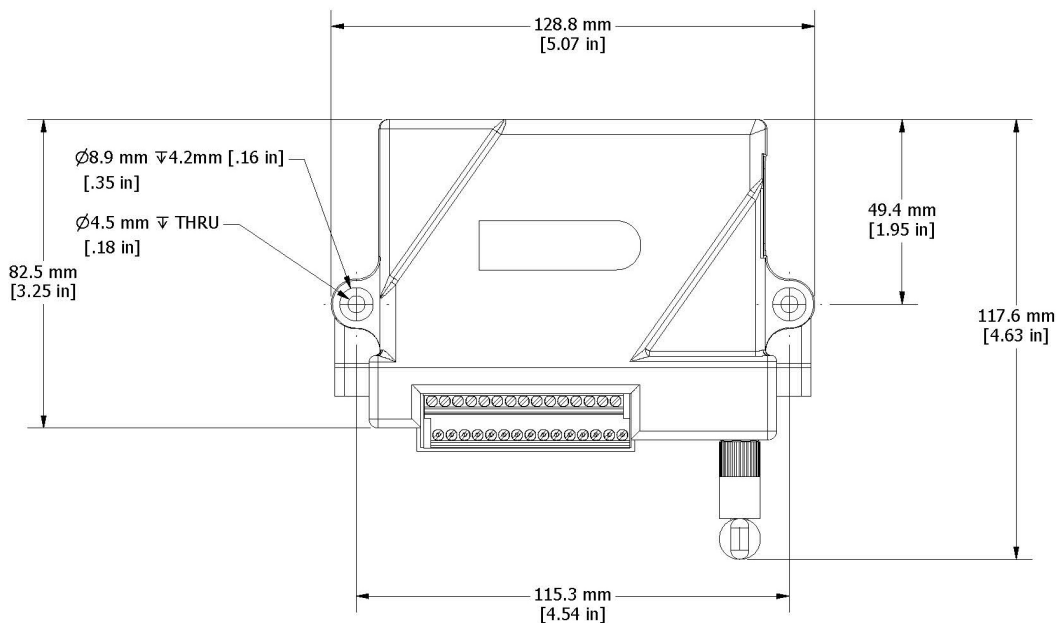

Figure 27 - Mounting the Node

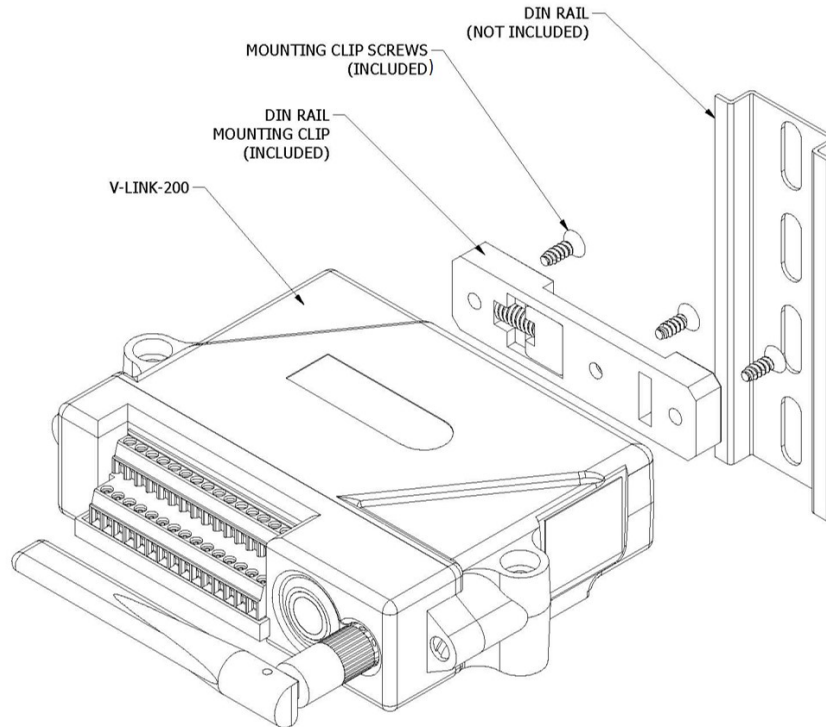

Figure 29 - DIN Rail Mount Option

## 5.2 Optimizing the Radio Link

### NOTE

In the event of communication difficulties, it may be necessary to disable WIFI on the host computer, or use a USB extender when collecting data.

The best method for ensuring optimal radio communication is to conduct an RF survey of the installation site. This is easily accomplished in SensorConnect by using the range test feature to quantify the radio signal strength (RSSI) in various scenarios. [See Range Test on page 35](#) for instructions on using SensorConnect for measuring RSSI. The following are general guidelines for maximizing communication range:

- **Line of Sight (LOS)** between the node and gateway. Try to avoid obstructions such as buildings, terrain, vegetation, or other physical barriers.
- **Increase the Mounting Height** of the node to allow a clearer LOS path to the gateway. Height above the ground is also important because reflections off of the ground can interfere at the receiver. Generally, the higher above the ground the better.
- **Minimize Radio Frequency Interference (RFI)** from other wireless devices, especially those operating in the same frequency range. This includes other nodes and 2.4 GHz WIFI routers. If other wireless devices are required nearby, mount them at different heights to minimize interference. Additionally, a different radio frequency may be selected using SensorConnect software.
- **Minimize Electromagnetic Interference (EMI)** such as that which is generated by power transmission equipment, microwaves, power supplies, and other electromagnetic sources.
- **Metal Objects** in close proximity to either antenna, particularly ferrous metals such as steel and iron, can be problematic for wireless communications. The larger the object, the greater the influence.

## 5.2.1 Range Test

After establishing communication between node and gateway, use the range test feature in SensorConnect to monitor the signal strength and to optimally position the nodes, gateway, and antennae for installation. Maximum achievable range is determined by the gateway and node power settings (found in the device Configure menu) and is highly dependent on the physical environment surrounding the devices.

1. Select the node name > Range Test

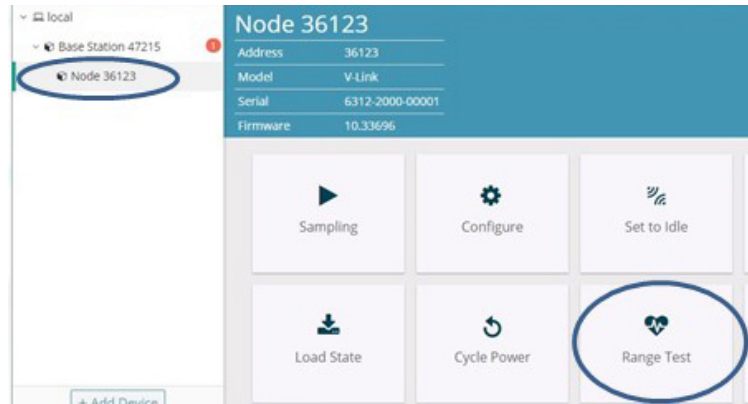

Figure 30 - Range Test Menu

2. RSSI is a measure of signal strength between the node and the base station. A higher RSSI value (closer to zero), will result in better node to base station communication. Reliable communication can be achieved with a signal strength greater than -75 dBm, in the absence of radio frequency interference. Position the node and gateway antennas where the best RSSI value is observed.

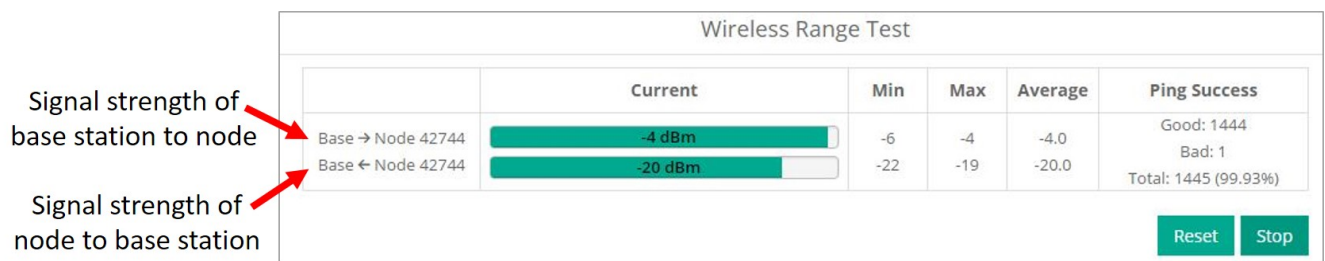

Figure 31 - Range Test Statistics

## 6. Connecting Sensors

The V-Link-200 wireless sensor node features eight analog input channels that interface with a wide range of available sensor technologies, essentially converting them into wireless sensors. The node accommodates Wheatstone Bridge and analog sensors for applications in wireless strain gauge monitoring, such as torque, force, and pressure measurement, as well as sensors for other applications like wireless accelerometers, vibration sensors, magnetic field and displacement sensors. Environmental sensing can be achieved with wireless RTD and wireless thermocouple monitoring.

The V-Link-200 includes four single ended and four differential channels for sensor measurement. Differential channels may need to be factory-set to work for specific types of sensors. For information about channel configurations [see \*Differential Input Channels on page 41\*](#). For ordering information [see \*Wireless Equipment on page 83\*](#).

### 6.1 Sensor Requirements

Below are guidelines for selecting sensors for use with the V-Link-200. For interfacing with sensors outside of these parameters, or not included in the examples in the following sections, contact Technical Support ([see \*Technical Support on page 81\*](#)).

#### Sensor Impedance:

- Differential sensor inputs using a Wheatstone Bridge must have an impedance that is  $\geq 120 \Omega$ . For half-bridge and quarter-bridge configurations, the node impedance value is set to match the sensor when the node is manufactured and must be specified at the time of order. For more information [see \*Wireless Equipment on page 83\*](#). Custom bridge completion impedance values are available on request.

#### Sensor Signal Voltage:

- Differential sensor inputs include a hardware gain and offset stage before the sensor input signal is processed by the analog to digital voltage converter within the node. The combination of the gain, offset, and sensor signal voltage cannot exceed the 5 V dc input range of the analog to digital converter. For more information [see \*Differential Input Gain and Offset on page 67\*](#).
- Single-ended sensor signal voltages are measured with respect to the system ground and must be between -10.24 to +10.24 V dc.

#### Sensor Power:

- The total current available for all connected sensors must be less than 150mA. The voltage is 4.096 V dc.



## 6.2 Wiring Recommendations

It is good practice that all sensor wiring be done with shielded cable. The shield is connected to the system ground only at one end to avoid ground loops. For sensitive small voltage signals (such as strain gauges) sensor wire leads should be of matched lengths so the lead resistance for each connection is as close to the other as possible. For long lengths of wire, a system calibration is recommended over a sensor calibration. [See \*Sensor Calibration on page 51\*](#).

### 6.3 Sensor Power

#### CAUTION

Total sensor current draw of more than 150mA can cause permanent damage to the node and should be avoided.

Sensors can be powered by the node or with an external power supply. The node sensor excitation voltage is 4.096 V dc and can provide up to 150mA total on all channels. If a higher voltage or more current is required for the sensor, an appropriately sized external power supply can be used. For example, using the node battery for current intensive devices such as 4 to 20mA sensors will drain the battery quickly. For these applications, an external source is recommended for the sensor or the node.

Drain on the battery can also be limited by selecting low resource sampling modes and low duty sampling rates, which automatically switch the node excitation voltage off after sampling. This feature can also be utilized to turn switches on and off to further control resource use. [See Using the Excitation Output as a Switch on page 48.](#)

External battery holders and ruggedized outdoor housings that accommodate larger batteries are available for the V-Link-200 and can be used to extend battery operating capacity and duration. [See Node Accessories on page 83.](#)

### 6.4 Node Channels Designations

Channel	Description	Pin Nomenclature
1	differential channel 1	S1
2	differential channel 2	S2
3	differential channel 3	S3
4	differential channel 4	S4
5	single ended channel 1	Ain5
6	single ended channel 2	Ain6
7	single ended channel 3	Ain7
8	single ended channel 4	Ain8

**Table 1 - Channel Designations**

## 6.5 Terminal Block Connections

When inserting the sensor leads into the terminal block ensure the lead wire is being clamped under the terminal screw and not the lead insulation. If the sensor wires are a very fine gauge, folding and tinning them may be useful to provide more area for the terminal screw to make contact. Failure to provide adequate connection may result in erroneous data.

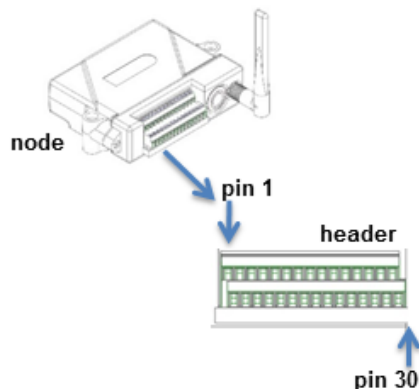

Node Pin Number	Signal	Node Pin Number	Signal
1	SP+	16	SP+
2	S1+	17	S4+
3	S1-	18	S4-
4	GND	19	GND
5	S1 S	20	S4 S
6	SP+	21	Ain5
7	S2+	22	GND
8	S2-	23	Ain6
9	GND	24	GND
10	S2 S	25	Ain7
11	SP+	26	GND
12	S3+	27	Ain8
13	S3-	28	GND
14	GND	29	Vin
15	S3 S	30	GND

**Table 3 - Terminal Block Connections**

## 6.6 Pin Descriptions

Signal	Description	Pin Type	Range
Vin	<p><b>Node external power supply</b></p> <p>An alternate to the node power jack. <i>See Powering the Node on page 69.</i></p>	power input	7.5 to 36 V dc sufficient current capacity for sensors
GND	<p><b>Return</b></p> <p>For node power and sensor excitation</p>	power return	return
S+	<p><b>Sensor excitation</b></p> <p>Power to external sensors. At sampling rates under 32Hz, it is only active when the node is sampling the sensors.</p>	output	4.096 V dc maximum combined load on all excitation pins is 150 mA.
Sx+	<p><b>Differential sensor input +</b></p> <p>Positive input to the node programmable gain amplifier (PGA). Used with S-.</p>	input	0 to 5 V dc including gain and offset Wheatstone Bridge compatible sensor with 120 $\Omega$ input impedance recommended
Sx-	<p><b>Differential sensor input +</b></p> <p>Negative input to the node programmable gain amplifier (PGA). Used with S+.</p>		
Sx S	<p><b>Three wire input</b></p> <p>Used only for three wire configuration of quarter bridge strain gauge bridges. Leave unconnected for non quarter strain gauge bridge applications.</p>	input	4.096 V dc including gain and offset Wheatstone Bridge compatible sensor with 120 $\Omega$ input impedance recommended
Ainx	<p><b>Single ended sensor input</b></p> <p>Routed directly to the node analog to digital (A/D) converter. Return is node GND.</p>	input	-10.24 to +10.24 V dc

**Table 4 - Node Pin Descriptions**

## 6.7 Differential Input Channels

The differential measurement channels provide a 5 V dc excitation voltage to the sensor and measure the resulting sensor signal output. The sensor signal goes through a programmable gain amplifier (PGA) and is then processed in the node by a 18-bit analog-to-digital (A/D) converter over the 5 V dc range. The resolution of the sensor measurement is dependent on the operating range of the sensor. If the application is such that only a small portion of the 5 V dc range is being utilized, better resolution can be achieved by increasing signal amplification and by zeroing the sensor baseline in the appropriate offset biasing range. Sensor gain and offset values are configurable in SensorConnect. [See Configure Node on page 21.](#)

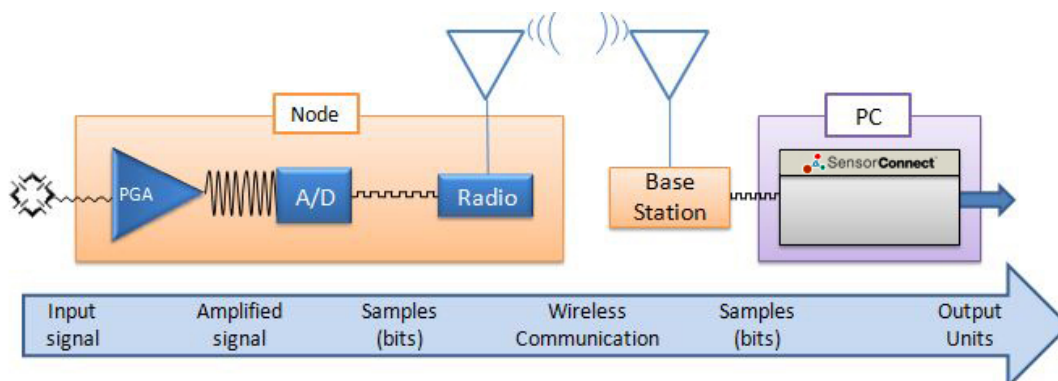

Figure 32 - Differential Channel Signal Processing

### 6.7.1 Differential Sensors

Sensors that are classified as differential sensors often utilize a Wheatstone Bridge configuration. These sensors are essentially a resistive load that use the bridge configuration to detect very small resistive changes and produce a precise voltage output as a result. Some examples include strain gauge elements or strain gauge-based sensors, such as some load cells and pressure transducers, as well as some soil moisture, temperature, and other sensors. For use with the V-Link-200, sensors with an impedance of  $\geq 120 \Omega$  are recommended.

Calibration in the SensorConnect software for these devices varies depending on the type of sensor and includes using the shunt calibration for strain gauges. The following diagrams show how to connect these types of sensors. Note: Full-Bridge is the standard LORD Sensing offering. Calibration for Half-Bridge, Two Wire Quarter-Bridge, and Three Wire Quarter-Bridge requires the optional on-board bridge completion. [See Sensor Calibration on page 51](#) for more information.

#### KEY

x = channel number  
 Rx = sensor element or resistor  
 → = variable value

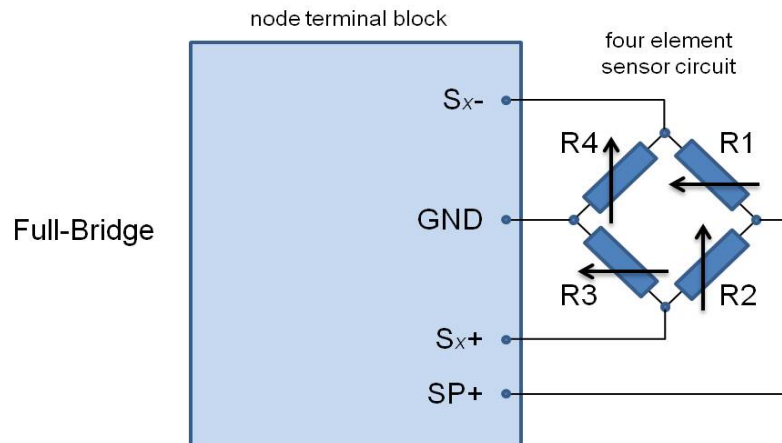

Figure 33 - Full Bridge Wiring

**KEY**

x = channel number  
 Rx = sensor element or resistor  
 → = variable value

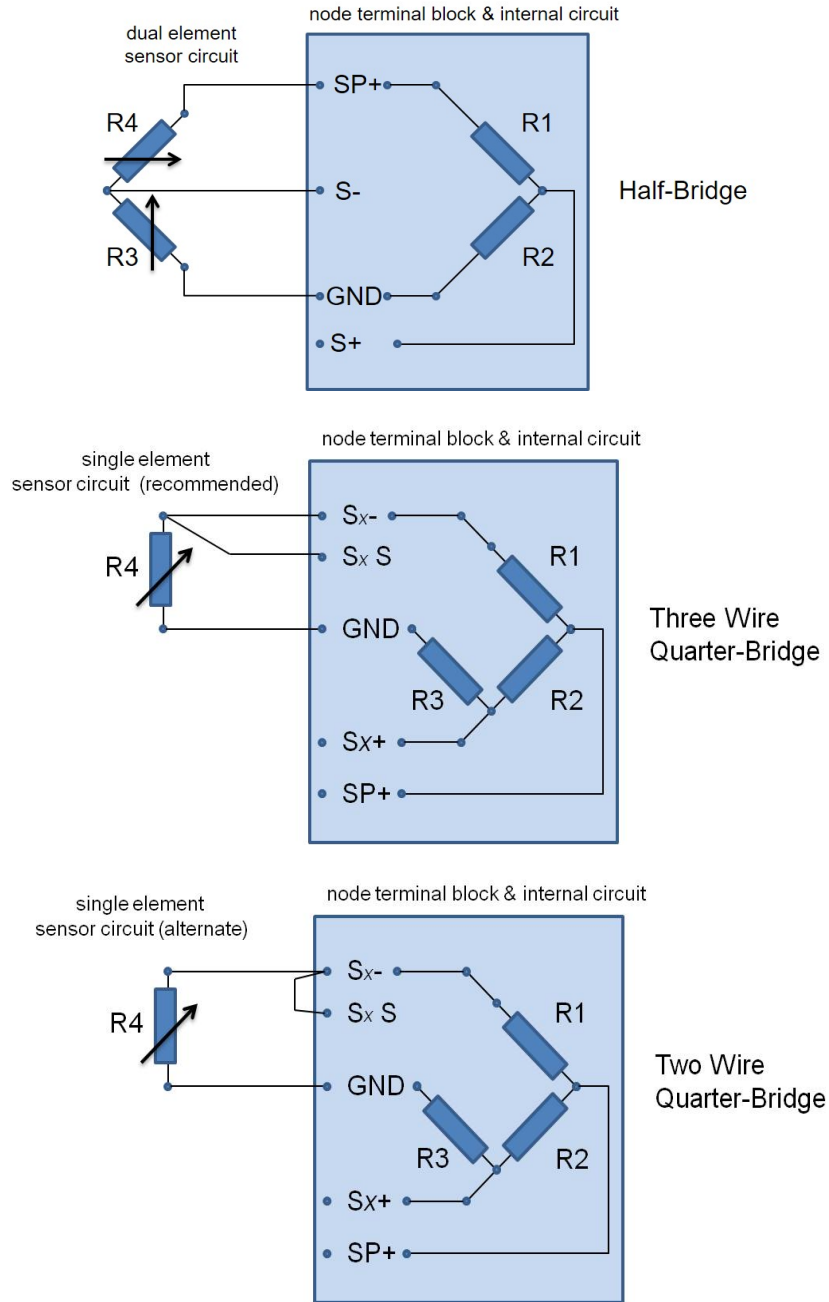

Figure 34 - Half and Quarter-Bridge Wiring

## 6.7.2 Differential Channel Raw Voltage

To set the V-Link-200 to show the raw voltage that is being applied (in mV) to channels 1 -4 (differential channels), enter the slope and offset for the input range being used. ( *See Table 5 - below* )

Input Range	[Gain]	Slope	Offset
±156 mV	[16]	0.0012207031	-156.25
±78.1 mV	[32]	0.0006103516	-78.13
±39.0 mV	[64]	0.0003051758	-39.06
±19.5 mV	[128]	0.0001525879	-19.53
±9.76 mV	[256]	0.0000762939	-9.77
±4.88 mV	[512]	0.0000381470	-4.88
±2.44 mV	[1024]	0.0000190735	-2.44
±1.22 mV	[2048]	0.0000095367	-1.22

**Table 5 - Raw Voltage Output**

The formula to derive the above raw voltage output:

$$\text{Slope} = 5120\text{mv} \div (262144 * \text{gain})$$

$$\text{Offset} = -(5000\text{mV} \div (2 * \text{gain})) \text{ (Assuming balance to mid-scale is perfect)}$$



### 6.7.3 Measuring Small Voltages

Some sensor types that have small signal voltages (around 20 mV or less) may be better measured by biasing the sensor signal to the mid range of the node input range with a voltage divider, as shown in [Figure 35 - Small Voltage Measurement](#).

Channel configuration will include adjusting the gain setting accordingly in the SensorConnect software.

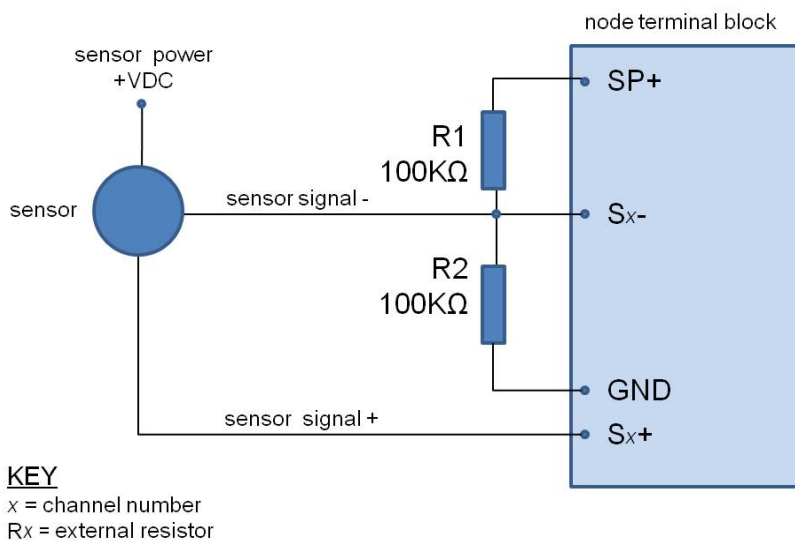

Figure 35 - Small Voltage Measurement

## 6.8 Single-Ended Input Channels

Single-ended channels are designed to measure voltages with reference to the system ground and can accommodate many analog sensors types including accelerometers, pressure transducers, geophones, temperature sensors, inclinometers, and more. These channels can also be used to measure reference voltages.

Sensors that operate on 4.096 V dc can be powered with the node excitation voltage. Alternately, sensors can be powered with an external source.

The sensor output signal is processed in the node by an 18-bit analog to digital (A/D) converter, over the -10.24 to +10.24 V dc range. The resolution of the sensor measurement is dependent on the full scale output range of the sensor. More resolution can be achieved by changing the single-ended channel input range, see below.

Voltage Range	Slope	Offset
±10.24 V	0.0000781250	-10.24
±5.12 V	0.0000390625	-5.12
±2.56 V	0.0000195313	-2.56
+10.24 V	0.0000390625	0
+5.12 V	0.0000195313	0

Table 6 - Single-ended Raw Voltage Ranges

The following sections provide examples of how various sensors can be connected to the node. For other applications, [see Technical Support on page 81](#).

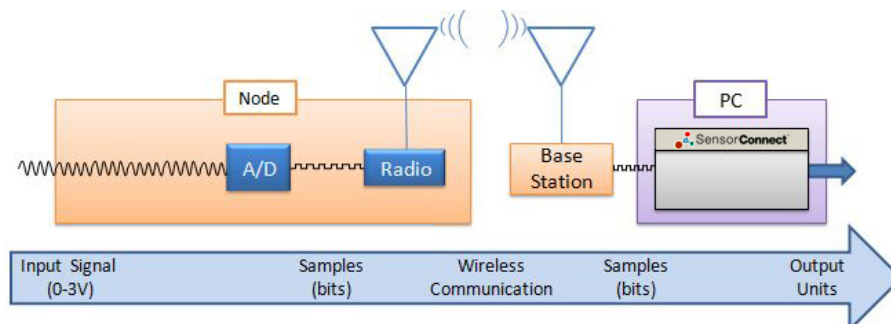

Figure 36 - Single Ended Signal Processing

### 6.8.1 Measuring Small Currents (4 to 20mA Sensors)

LORD Sensing nodes with analog inputs, such as the V-Link-200 and , support a wide range analog sensors including acceleration, vibration, strain, load cells, torque, pressure, magnetic fields, displacement, geophones, and more. To support these sensors, the nodes measure small voltage. Additionally, sensors with small current outputs, such as 4 to 20mA sensors, can be used with the nodes by adding a precision sampling resistor across a single-ended input channel to the node. An example circuit is shown in [Figure 37 - Small Current Measurements](#) .

- **Node Channel and Sensor Output Range:** Either the single-channel or differential analog input channel can be used to measure current. The external circuit and node settings are different for each. The single-ended option is simpler allows less adjustment. For applications in which very small currents will be measured, the differential inputs offer better noise immunity and programmable gain settings. Available gain settings vary between node models. Differential inputs can be factory configured for various bridge completion and impedance values. For this application, the standard full-bridge configuration is assumed. For other configurations contact LORD Sensing Technical Support.
- **Power Source:** If the sensor will be operating continuously in the 20mA range, or if multiple analogs inputs are in use, it is recommended that an external source be used to power the sensor or the node. Typically nodes can only supply 50mA (to all sensors), so 20mA would be a significant portion of the node capacity and would drain the internal battery quickly. However for applications with lower current requirements and measurement ranges, the internal battery may be a better option to mitigate potential noise sources, especially when using differential channels.

For battery life and current draw information [see Using the Internal Node Battery on page 69](#). The current limitations can be mitigated by using an external power source for the sensor or the node. If using node excitation power is the best for the application, drain on the battery life can be limited by only switching the node excitation voltage on just before sampling and then turning it off afterward. This happens automatically at low duty sampling rates (32Hz or lower) and can be set up for other sample rates with external circuitry. For more information [see Using the Excitation Output as a Switch on page 48](#).

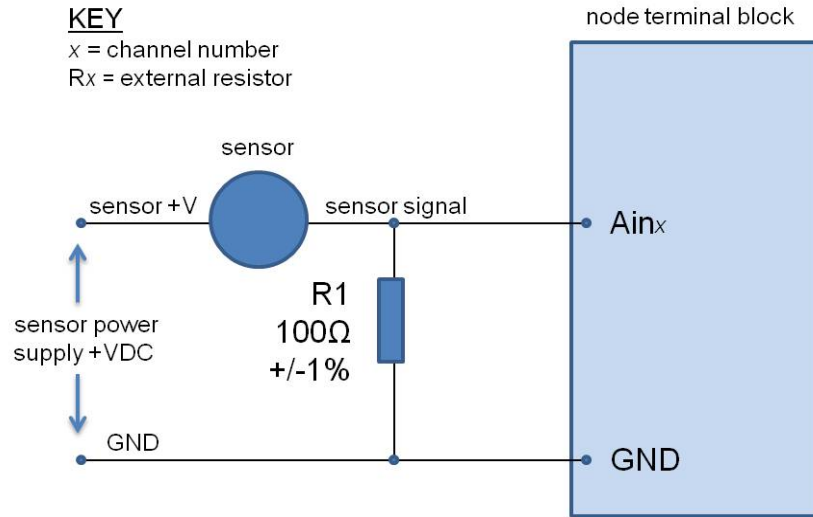

Figure 37 - Small Current Measurements

## 6.9 Using the Excitation Output as a Switch

At low sampling rates (under 32Hz) the node automatically switches the excitation voltage output off when the sensor is not being sampled, in order to conserve battery life. This feature can also be used in applications where a switch is desired, such as for turning sensor power on and off when the sensor is powered by the node but has a large current draw. It can also be used as a general purpose switch, such as for controlling a relay or transistor. The same limitations apply as to a sensor; the device must operate on 4.096 V dc and not require more than 150mA when combined with all other sensor current draw. To use the excitation output in this way, connect the control line of the device (example: relay coil or NPN transistor base) to the excitation pin on the node terminal block (SP+) and reference (example: other side of the relay coil or the NPN transistor emitter) to the node ground pin (GND).

## 6.10 Connecting Accelerometers

LORD Sensing bridge type accelerometers, such as the Triaxial Accelerometer Cubes, can be used with V-Link-200 to create wireless acceleration sensor platforms. Connect each accelerometer axis output to a node differential input channel. Power is provided to the accelerometer from the node excitation supply.

For additional information on LORD Sensing accelerometers compatible for use with the V-Link-200, [see Recommended Sensors on page 84](#). For information on integrating other types of sensors not described in this manual, contact Technical Support ([see Technical Support on page 81](#)).

## 6.11 On-board Temperature Sensor

- The V-Link-200 has an on-board, solid state temperature sensor mounted on the surface of the circuit board.
- Available as a channel in the Diagnostic Packet.
- The temperature sensor has a measurement range of -40°C to +85°C range with an accuracy of  $\pm 0.5^{\circ}\text{C}$  @25°C.

## 7. Sensor Settings

LORD Sensing sensor nodes are designed to accept many sensor types. The node configuration interface includes settings for measurement units and conversion values. There are preset measurement units, as well as a user-defined field. Because the wireless sensor system is digital, the analog voltage readings from the sensors are converted into a digital equivalent value based on the volt-to-bit scale of the internal analog-to-digital voltage converter (A/D converter). Sensor readings can be displayed and recorded in A/D value (bits) directly or further converted to engineering units by applying conversion values and a conversion formula. For more information, [See Sensor Conversion Values on page 61.](#)

Some sensors require calibration to determine more accurate conversion values. Calibration incorporates coefficients that normalize the sensor output to a known reference device and guarantee accuracy of conversions.

External sensors can be attached to any channel that is suitable for sensor type. [Table 7 - Example External Sensor Types](#), describes example sensors, units, and calibration options.

channel type	example external sensors	units	calibration options
analog differential input	strain gauges in full, half, quarter/custom Wheatstone Bridge configurations	strain volts A/D value custom	shunt calibration user entry from manufacturer data, lab or field calibration
	other Wheatstone Bridge sensors such as: some pressure sensors some force sensors some mass sensors some displacement sensors some accelerometers some temperature sensors 4-20mA sensors	g-force A/D value volts custom English and metric measurements for; mass, pressure, force, distance, and temperature.	user entry from manufacturer data, lab or field calibration
analog single ended input	sensors with voltage outputs referenced to the system ground.	volts A/D value custom	user entry from manufacturer data, lab or field calibration
thermocouple	thermocouples	temperature A/D value custom	user entry from manufacturer data, lab or field calibration

**Table 7 - Example External Sensor Types**

## 7.1 Sensor Calibration

Many sensors require calibration coefficients to accurately report measurements. Methods for determining the calibration coefficients depend on the type of sensor measurement and application. The SensorConnect software facilitates multiple calibration methods. Calibration calculators for some applications are also available by contacting LORD Sensing Technical Support. [See Technical Support on page 81.](#)

- **Sensor manufacturer's specifications or calibration:** The slope and offset values, or the data to derive them, are provided with the sensor by the manufacturer to prove its accuracy and describe expected voltage output. Some sensors are calibrated individually, while others are manufactured to a standard sensitivity value (plus or minus some tolerance), which is provided in the device specifications.
- **Sensor lab calibration:** If the manufacturer's calibration is not available or outdated, calibration of the sensor can be performed with calibrated equipment in a controlled environment. The calibration equipment and process will typically be traceable to an industry standard, such as NIST or ASTM in the United States. Fixed loads are applied to the sensor while the sensor output is recorded. The load is applied or measured by a calibrated reference device. The known load value from the calibrated device is then plotted against the measured output of the sensor to determine the calibration slope and offset. In SensorConnect this can be accomplished by taking sensor readings while applying the known loads.

Sensor wiring, tolerances in system electronics, and differences in mounting techniques are examples of systemic variables that can influence the sensor readings. Sensors that are making small measurements or are otherwise sensitive to these slight differences may benefit from a system calibration. The following techniques are system calibrations:

- **System shunt calibration (internal and external):** This option is only available for Wheatstone bridge-type sensors (such as strain gauges) in SensorConnect. In the shunt calibration process, an internal or external precision resistor is used to load part of the sensor bridge while the sensor remains unloaded. The bridge output is measured and used as a loaded calibration point for the sensor. In addition to the no-load value it can be used to derive the calibration slope and offset. The internal shunt resistor is suitable for most applications, however an external shunt may be beneficial in high gain scenarios.
- **System field calibration:** The field calibration is a similar methodology to the sensor lab calibration. Known loads are applied to the sensor while the sensor output is recorded. The load is applied or measured by a reference device. In this scenario, the sensor may be installed in final field configuration, and the load may be applied with the actual stimulus that

the sensor will be monitoring. The known load value from the reference device is then plotted against the measured output of the sensor to determine the calibration slope and offset. In SensorConnect this can be accomplished by taking sensors readings while applying the known loads.



### 7.1.1 EXAMPLE: Internal Shunt Calibration

**NODE:** V-Link-200, 18 bit (262144 A/D values)

**CHANNEL TYPE:** differential analog input, 0 to 5 V dc input range

**SENSOR TYPE:** strain gauge, Wheatstone Bridge, full bridge configuration

**SENSOR PARAMETERS:** application voltage range: +/-2 mV

This is the expected output voltage of the strain gauge based on the range of strain being measured in the application and the sensitivity of the gauge (volts/strain).

**DESIRED OUTPUT:** engineering units, microstrain

#### PROCEDURE:

1. Open SensorConnect and establish communication with the gateway and node. ([See System Operation on page 14](#)).
2. Select Hardware > Input Range for channel 1, select +/-2 mV from the drop down menu.
3. Under Hardware Offset, select Balance Target for channel 1, select Mid (50%) from the drop down menu.
4. Select Auto-Balance. When auto-balance is complete, a blue information window will indicate the balance result.

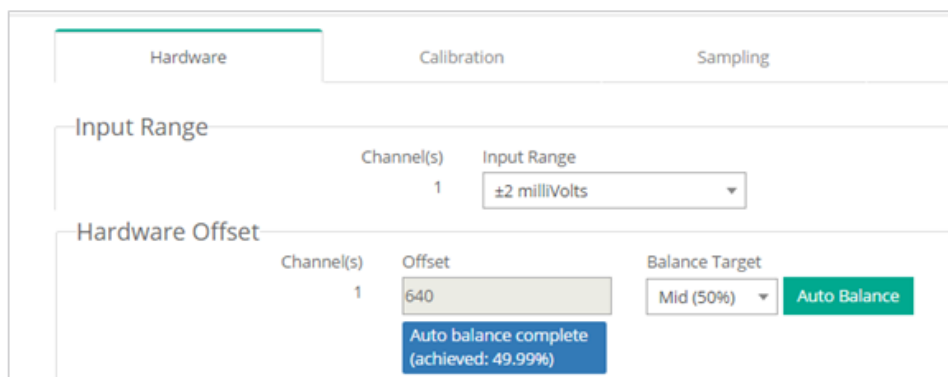

Figure 38 - Auto-Balance

5. Select Calibration.
6. Select Microstrain from the Unit drop down menu, select the Shunt Cal button enabled on the right.

Channel(s)	Slope	Offset	Unit
1	1	0	Microstrain

Figure 39 - Node Configuration Menu

7. Use the following settings:
  - a. **Calibration Mode:** Is either Internal (using the shunt resistor on the V-Link-200) or External (using an external shunt resistor).  
  
For this example, Calibration Mode is set to: Internal
  - b. **Number of Active Gauges:** Typically full-bridge is 4, half-bridge is 2, and quarter-bridge is 1.  
  
For this example, Number of Active Gauges is: 4
  - c. **Gauge Factor:** Is a specification from the gauge.  
  
For this example, Gauge Factor is: 2
  - d. **Gauge Resistance:** Is a specification from the gauge.  
  
For this example, Gauge Resistance is: 1000
  - e. **Shunt Resistance:** 499000
8. Select Start Shunt Cal for Slope and Offset calibrations.
9. Select Accept Calibration.

Shunt Calibration

Node: 78 - Channel: ch1

Calibration Mode: Internal

# Active Gauges: 4

Gauge Factor: 2

Gauge Resistance: 1000 ohm

Shunt Resistance: 499000 ohm

Simulated Strain: 250

Start Shunt Cal

**Figure 40 - Channel Settings**

10. When the calibration is complete, the Wireless Node Configuration window will appear.
11. Select Apply Configuration to write to node memory.

### 7.1.2 Calibration Lab or Field

The lab and field calibrations use similar methodology. [See Sensor Calibration on page 51](#). The primary difference is the traceability and calibration environment. Lab calibrations are performed in controlled environments with traceable equipment and procedures. Field calibrations are more improvised, although calibrated equipment can still be used to improve accuracy.

**NODE:** V-Link-200, 18 bit (262144 A/D values)

**CHANNEL TYPE:** differential analog input, 0 to 5 V dc input range

**SENSOR TYPE:** load cell

**SENSOR PARAMETERS:** application voltage range: +/-2 mV

This is the expected output voltage of the sensor based on the range of force being measured in the application and the sensitivity of the sensor (V/engineering units)

**DESIRED OUTPUT:** engineering units (EU), force (lbs)

#### PROCEDURE:

1. Open SensorConnect and establish communication with the gateway and node ([See System Operation on page 14](#)).
2. Select Hardware > Input Range for channel one, select +/-2 mV from the drop down menu.
3. Under Hardware Offset, select Balance Target for channel one, select Mid (50%) from the drop down menu.
4. Select Auto-Balance. When auto-balance is complete, a blue information window will indicate the balance result.

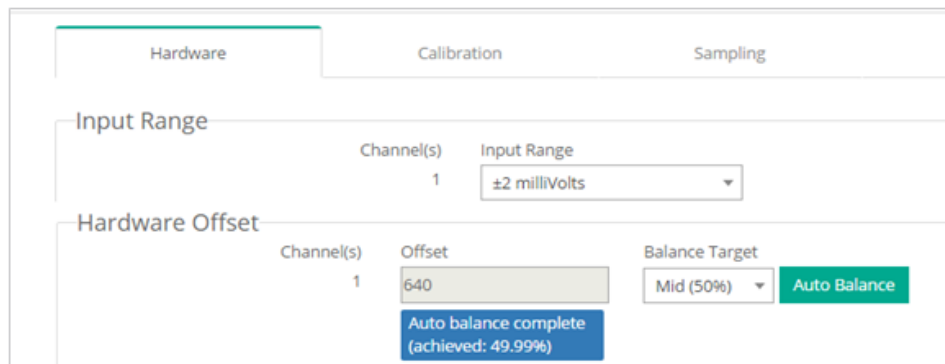

Figure 41 - Auto-Balance

5. Select Calibration.
6. Use the following settings:
  - a. **Slope:** 1
  - b. **Offset:** 0
  - c. **Units:** Bits
7. Select Apply Configuration. When the settings have been applied, a green pop up window will confirm the process is complete.

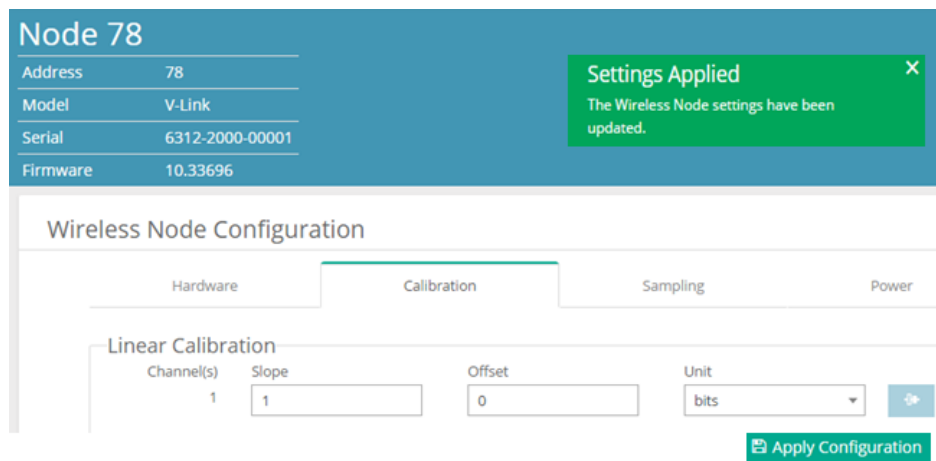
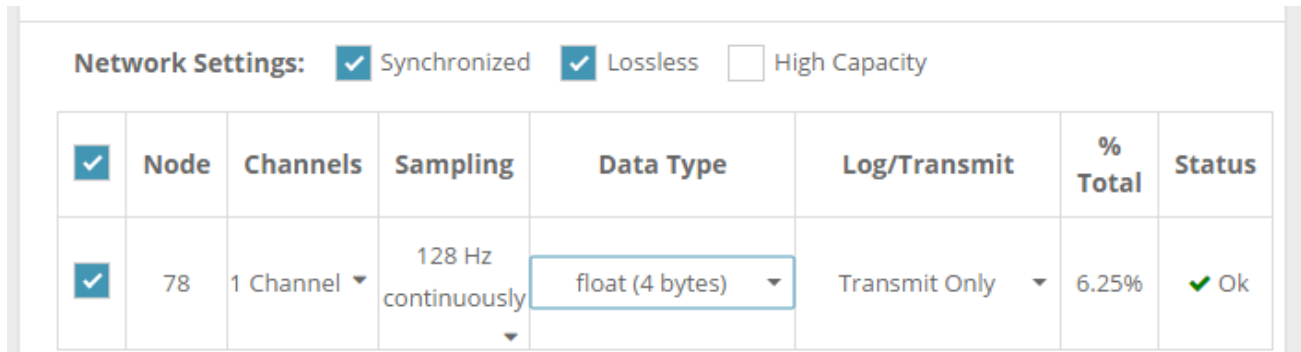

Figure 42 - Node Configuration Menu

8. To start sampling, click on the node name and select Sampling
9. The node is included in the sampling by default and is indicated by a white check mark in the blue box to the left of the Node number. Uncheck any nodes to be excluded in the sampling.
10. Use the following settings:
  - a. **Channel:** 1
  - b. **Hertz:** 128
  - c. **Float:** 4
  - d. **Log/Transmit:** Transmit Only



**Network Settings:**  Synchronized  Lossless  High Capacity

<input checked="" type="checkbox"/>	Node	Channels	Sampling	Data Type	Log/Transmit	% Total	Status
<input checked="" type="checkbox"/>	78	1 Channel	128 Hz continuously	float (4 bytes)	Transmit Only	6.25%	✓ Ok

Figure 43 - Channel Settings

11. Select Apply and Start Network.
12. Select the Quick View Dashboard pop up window to view sampling.
13. After making all measurements, calculate a slope from the data using the formula  $y=mx+b$  in a data analysis program, such as Microsoft Excel. [See Calculating a Linear Slope on page 65.](#)
14. Return to the Wireless Node Configuration screen for the sensor channel, select Calibration, and enter the Slope and Offset values derived in the data analysis program.

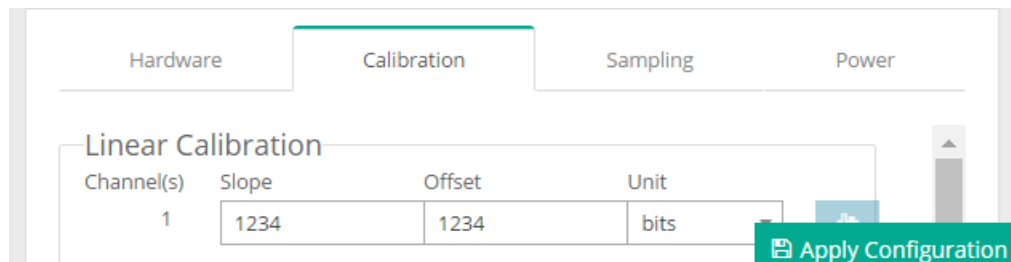

Hardware Calibration Sampling Power

Linear Calibration

Channel(s)	Slope	Offset	Unit
1	1234	1234	bits

Apply Configuration

Figure 44 - Enter Calibration Values

15. Select Apply Configuration to save the values selected.
16. Collect data again with no load on the sensor.
17. Observe the value in the stream graph. If the value is not at zero, return to the Wireless Node Configuration menu, and adjust the offset by increasing or decreasing the value.
18. Once the offset has been zeroed, verify the calibration by applying known loads on the sensor throughout the load range, observing and verifying the measurement in engineering units.

### 7.1.3 Manufacturer Calibration

**NODE:** V-Link-200 , 18 bit (262144 A/D values)

**CHANNEL TYPE:** differential analog input, 0 to 5 V dc input range

**SENSOR TYPE:** pressure transducer, voltage output, positive going

#### **SENSOR PARAMETERS:**

From the manufacturer calibration sheet included with the sensor;

sensor range: 0-250 psi

sensor zero load output: 0.0032 V dc

sensor full scale output (FSO) with 10V excitation: 86.07 mV

From the application parameters;

sensor excitation in application: scaled to 4.096 V

**DESIRED OUTPUT:** engineering units (EU), psi

#### **CALCULATIONS:**

Because the sensor will be powered from the node with 4.096 V, and the sensor manufacturer calibrated it a 10 V, the manufacturer full scale output (FSO) value needs to be scaled to 3V.

$$(4.096 \text{ V}/10 \text{ V}) * 86.07 \text{ mV} = 35.25 \text{ mV}$$

Select a gain and offset scale value appropriate for the sensor. ([See Differential Input Gain and Offset on page 67](#)).

The closest gain setting that accommodates 35.25 mV is +/- 39.0 mV. Using a lesser value would exceed the input voltage capacity of the node when the sensor is at higher pressures. For more information about gain values and associated input ranges, [See This table lists the gain settings available on the V-Link-200 differential input channels. The scaled input range is the approximate signal range of a sensor that would work with that gain, without considering the offset setting. on page 68](#)

Multiply the sensor FSO by the gain setting to get the sensor voltage after amplification. For this example, the range is 39.0 mV for a gain of 64.

$$64 * 35.25 \text{ mV} = 2.256 \text{ V}$$



Scale the (gained) sensor input voltage/EU ratio to the node input voltage/EU ratio to determine the equivalent node FSO value ( $x$ ).

$$2.256 \text{ V}/250 \text{ psi} = 4.096 \text{ V}/x$$

$$(250 \text{ psi} * 4.096 \text{ V})/2.256 \text{ V} = x = 453.9 \text{ psi}$$

The node converts voltage inputs to A/D values. For an 18-bit node, there are 262144 A/D values over the 4.096 V input range. Divide the node EU FSO by the A/D value to get the ratio, or slope, of EU to A/D value.

$$453.9 \text{ psi}/262144 \text{ bits} = 0.00173 = \text{slope}$$

Once the slope is entered, the sensor offset value can be measured in a data sampling session, such as streaming. Sample the sensor channel with no load applied, and read the EU value. Enter this as a negative value for the offset in order to have it subtracted from readings.

## 7.2 Sensor Conversion Values

### NOTE

In order to report accurate readings, many sensors require calibration. Calibration coefficients normalize the sensor output to a known reference device and are often expressed in the measurement unit conversion values; the only difference being the use of a traceable reference. Calibration can be used to account for the variations between individual sensors, wiring, system electronics, sensor mounting and environmental conditions.

The conversion values include the slope, offset, gain, scale, and formula for converting the sensor A/D value (bits) to engineering units. The bits are the digital representation of the sensor voltage output. The type of sensor, channel, and desired engineering units determine what conversion values are available. The conversion values are entered through SensorConnect and saved in the node memory for the applicable channel.

Conversion values for the V-Link-200 are determined mathematically from the sensor sensitivity specifications, from the sensor manufacturer calibration data, or through a calibration process. Calibration incorporates coefficients that normalize the sensor output to a known reference device in order to guarantee accuracy of the sensor readings, especially when making small or precise measurements. [See \*Sensor Calibration\* on page 51](#) for more information. Not all sensors require calibration.

**Conversion Formula:** The conversion formula assumes a linear relationship between the original units (such as volts or A/D bits) and new engineering units (such as strain), and it is expressed mathematically as  $y=mx+b$ , where  $y$  is the engineering units at a given point (measurement),  $m$  is the slope of the line that represents the linear ratio,  $x$  is the original unit value at a given point, and  $b$  is a unit conversion offset (in the case of unit conversions) or the fixed zero load offset of the sensor (in the case of measurement calibration coefficients). Negative values may be entered for any coefficient.

**Slope:** is the linear scaling slope coefficient. The slope is the ratio of original units to new engineering units (EU), and it is used to convert the sensor measurements. The slope conversion value will vary depending on the engineering units desired. For example if the original unit is A/D values (bits), and the desired engineering units are acceleration in  $g$ -force, the slope conversion would describe how many bits equal one unit of  $g$ -force (bits/ $g$ ). Mathematically, the slope is  $m$  in the formula  $y = mx + b$ .

The screenshot shows the 'Linear Calibration' interface. It has three tabs: 'Hardware', 'Calibration', and 'Sampling'. The 'Calibration' tab is selected. Below the tabs, there is a 'Linear Calibration' section with the following fields:

Channel(s)	Slope	Offset	Unit
1	1	0	bits

The 'Unit' dropdown menu is open, showing a list of units: 'bits', 'count', 'Value', 'Millivolts Per Volt', 'Percent', 'Percent Lifetime', 'G\*Seconds', and 'Seconds per second'.

Figure 45 - Conversion Values Menu

**Input Range (Gain):** This sets the amplification of the signal within the node and is only available for channels with differential inputs and gain amplifiers.

**Hardware Offset:** is the linear scaling offset coefficient, and it is typically the starting output value of the sensor with no load applied (in the original units). Mathematically, the offset is  $b$  in  $y = mx + b$ .

**Anti-Aliasing Filter:** A filter applied before the digitization of the analog signal.

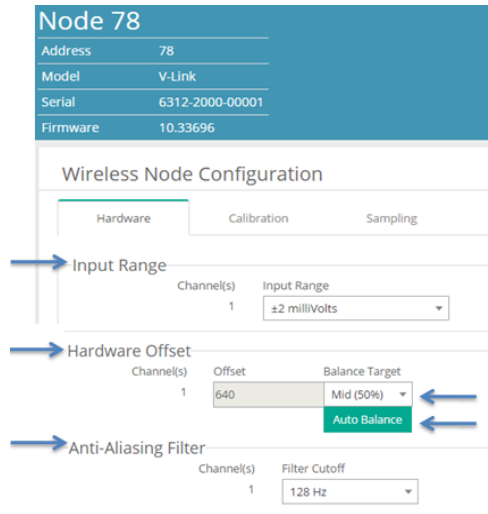

Figure 46 - Advanced Conversion Values Menu

**Offset Scale (with Auto Balance):** This feature is only available for channels with differential inputs, and assigns the position and value of the no load measurement of the sensor. The offset scale level adjusts the operating window of the sensor measurements in reference to the entire range. For example, in mid scale the sensor no load measurement will be placed in the middle of the range, providing 50% of the range for positive readings and 50% of the range for negative readings. Once the scale level is selected, the Auto Balance procedure is used to assign the actual sensor no-load measurement to the designated scale.

- Low is for positive-going signals (zero at 25% of total range).
- High is for negative-going signals (zero at 75% of total range).
- Midscale is for positive and negative-going signals (zero at 50% of range).

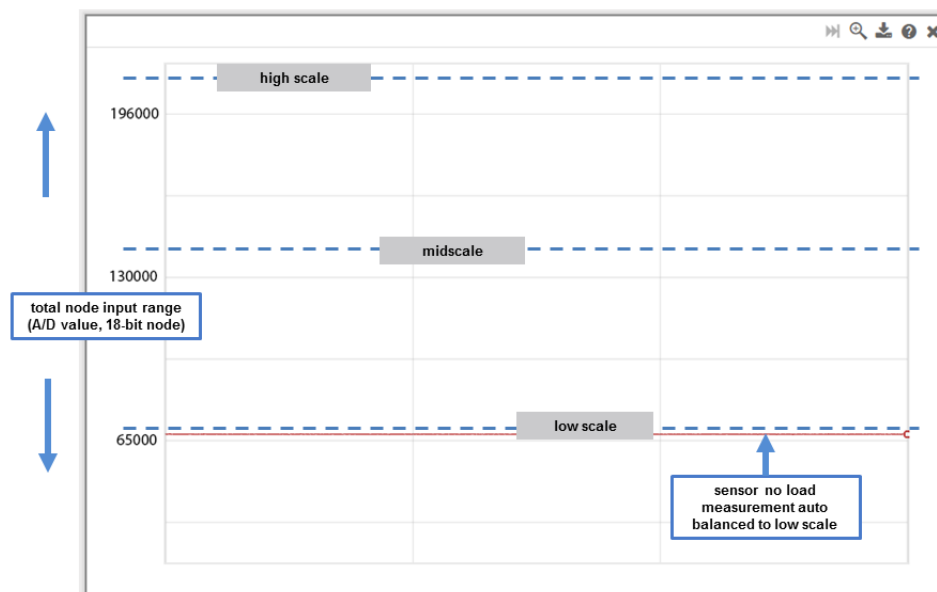

Figure 47 - Offset Scale Setting

## 7.2.1 Calculating a Linear Slope

A data analysis tool such as Microsoft Excel can be used to determine the slope of a linear relationship between sensor output A/D value (bits) and engineering units. This is not a calibration unless a calibrated reference device is used to measure the applied loads. For information and examples for determining calibration coefficients [see \*Sensor Calibration\* on page 51](#).

Here is an example, using Excel:

1. Open a blank spreadsheet.
2. Enter the A/D value (bits) measurements and applied load in the desired engineering units in two columns. Enter A/D value in the left column ( $x$ -axis value) and the applied load in the right ( $y$ -axis value).
3. From the Insert menu, select Chart > Scatter. Select the preferred format.

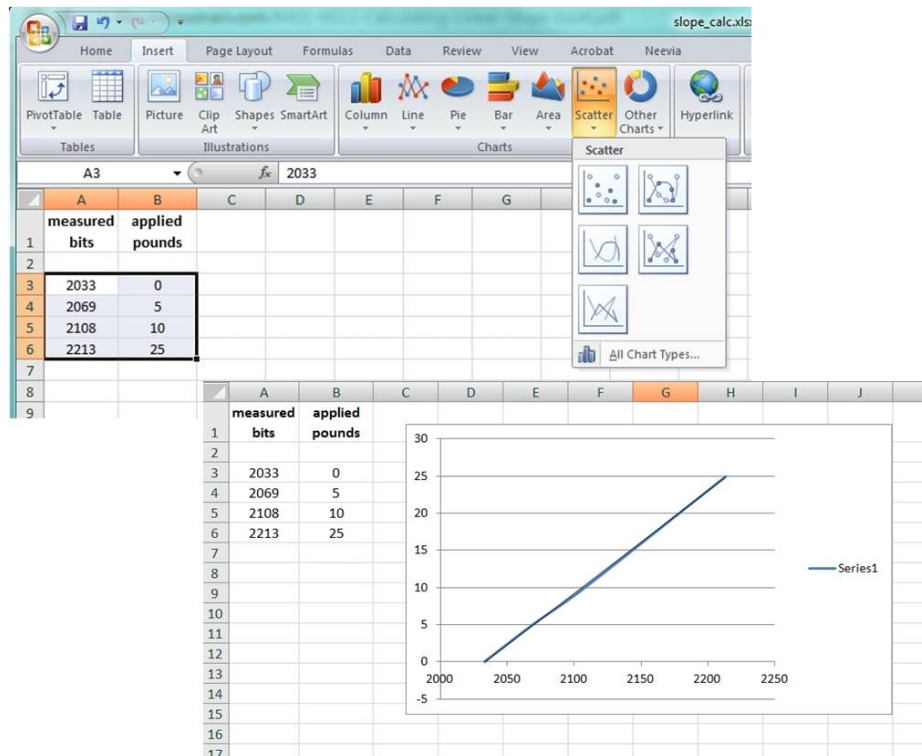

Figure 48 - Generate a Scatter Chart

4. Right-click on the graphed line, and select Add Trendline .
5. Designate the line as Linear, and check the option to Display the Equation on the chart.

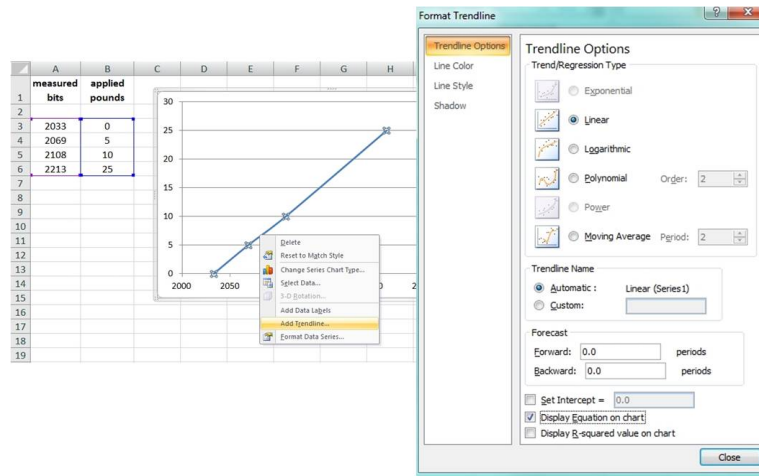

Figure 49 - Plot Trendline

6. The formula of the line is  $y=mx+b$ , where  $y$  is the engineering units at a given point (measurement),  $m$  is the slope of the line that represents the linear ratio,  $x$  is the A/D value at a given point, and  $b$  is the fixed zero load offset of the sensor. Enter the slope and offset as the conversion values for the sensor channel under the applicable engineering units. In this example, enter 0.1388 for the slope and -282.36 for the offset for the units conversion values on the measured channel.

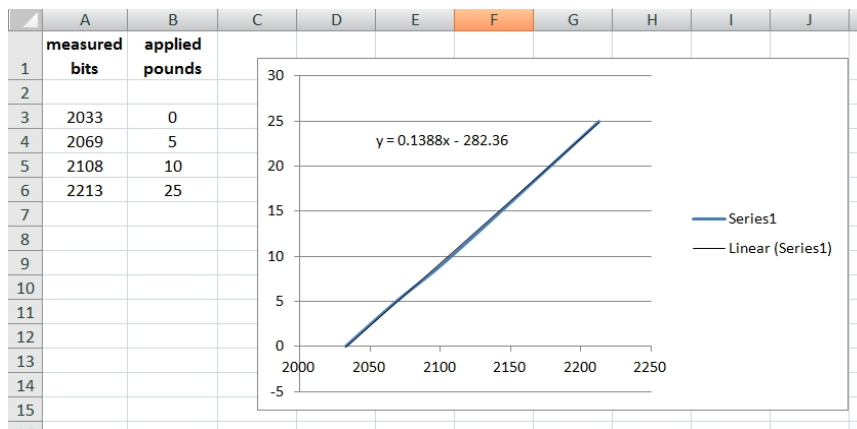

Figure 50 - Slope and Offset Values

## 7.2.2 Differential Input Gain and Offset

The combination of the gain, offset, and sensor signal cannot exceed the 0 to 5 V dc input of the analog to digital converter within the node.

**Resolution:** Applying gain to the sensor signal can be used to maximize the measurement resolution. The more of the range that is used, the more digital counts are available to measure the signal, which typically means higher resolution measurements. Limitations to the gain adjustment are the sensor's measurement capabilities and the 0 to 5 V input range of the node. The signal produced after gain is applied to the sensor at full scale must not exceed the input range of the node.

**Offset Scale:** The scale setting positions the no-load measurement of the connected sensor within the 0 to 5 V range of the node input. The range of A/D counts that corresponds with the 0 to 5 V node input depends on the resolution of the node. An 18-bit node will have a full scale bit range of 262144. A mid-range setting positions the baseline offset in the middle of the range (2.5 V or full scale bits\*1/2) and is used for sensors with negative and positive going signals. The low-range setting positions the baseline offset in the bottom quarter range (1.25 V or full scale bits\*1/4) and is used for sensors with mostly positive going signals. The high-range setting positions the baseline offset in the top quarter of the range (3.75 V or full scale bits \*3/4) and is used for mostly negative going signals.

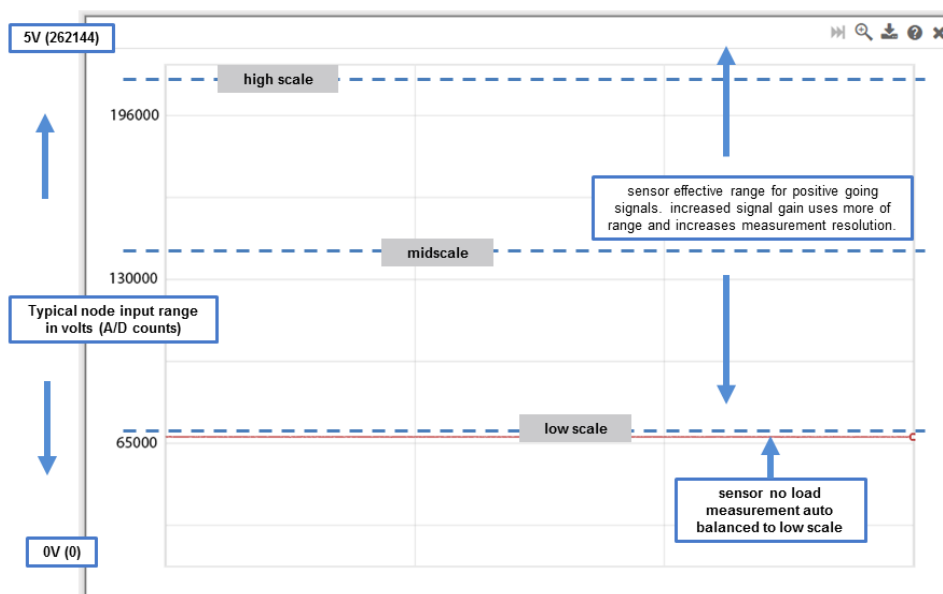

Figure 51 - Differential Input Resolution and Offset (18-bit Node)

This table lists the gain settings available on the V-Link-200 differential input channels. The scaled input range is the approximate signal range of a sensor that would work with that gain, without considering the offset setting.

Gain	Scaled input range
16	+/- 156 mV
32	+/- 78.1 mV
64	+/- 39.0 mV
128	+/- 19.5 mV
256	+/- 9.76 mV
512	+/- 4.88 mV
1024	+/- 2.44 mV
2048	+/- 1.22 mV

**Table 8 - Differential Gain Values**

Coefficients for Conversion to Volts:

$$\text{Slope} = 5.12 / (2^{18} * \text{gain})$$

$$\text{Offset} = -(5.0 / (2 * \text{gain})) \text{ (assuming balance to mid-scale is perfect)}$$



## 8.1 Powering the Node

The node can be powered with either the internal battery or an external source within the 7.5 to 36 V dc range.

### **WARNING**

Apply only the input voltage range specified for the . Failure to do so could result in personal injury and permanent damage to the ([see Safety Information on page 91](#)).

### **CAUTION**

The V-Link-200 is susceptible to damage and/or disruption of normal operation from Electrostatic Discharge (ESD). ESD may cause the device to reset, which may require user intervention to continue data acquisition.

### **NOTICE**

The electronics within the node are sensitive to moisture and static. Do not touch the internal circuitry or expose to liquids. Verify the node power switch is OFF before servicing.

## 8.2 Using the Internal Node Battery

The node is powered by four non-rechargeable, replaceable 3.6 V dc, 2.4 Ah, AA lithium batteries. If the node will not power, the batteries may need to be replaced. For more information on replacing the batteries [See Replacing Batteries on page 91](#).

Node battery life is highly dependent on the type of sensor connected, as well as operational parameters such as sample mode and rate. More active channels and higher sample rates equate to decreased battery life.

### 8.3 Connecting an External Power Supply

#### **⚠ WARNING**

Apply only the input voltage range specified for the . Failure to do so could result in personal injury and permanent damage to the ( [see Safety Information on page 91](#) ).

The node may be directly powered by a regulated AC to DC power supply with the appropriate output parameters, [see Operating Specifications on page 88](#) ). It can also be powered by an external battery or other regulated DC supply. The supply must deliver a stable voltage between 7.5 to 36 V dc and be capable of sourcing at least 100 mA.

External power is applied through the terminal block connector. Observe connection polarities, or the node may be damaged.

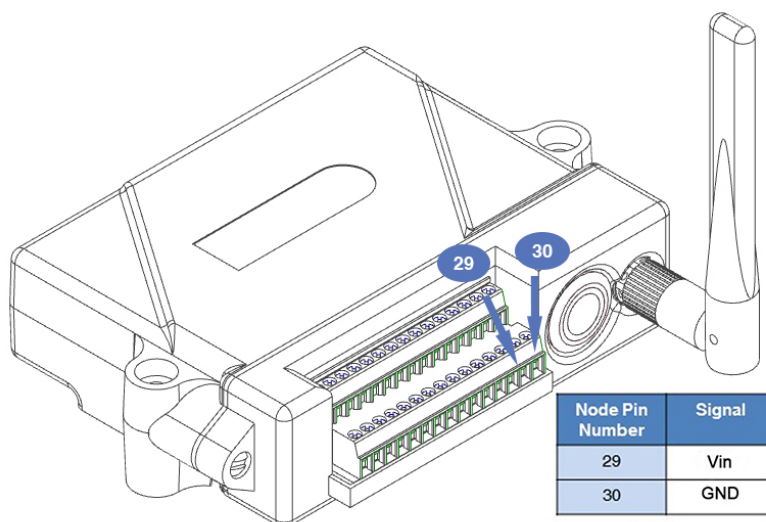
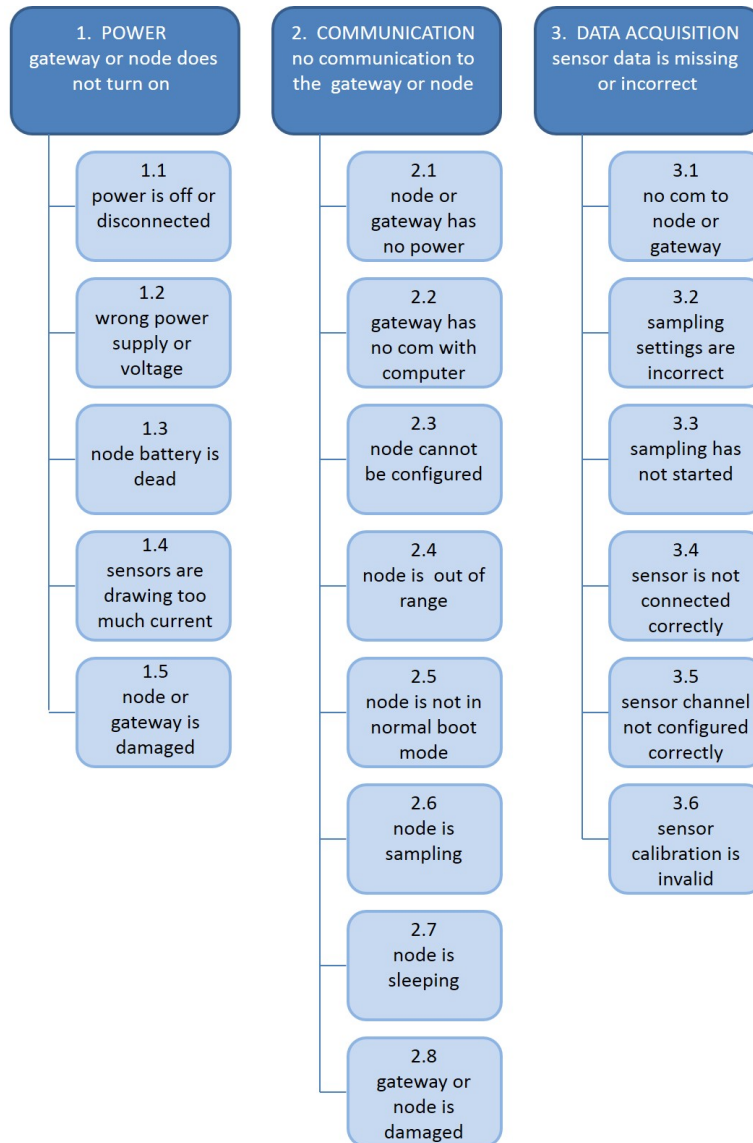

Figure 52 - External Power Connection

## 9. Troubleshooting

### 9.1 Troubleshooting Guide



	Possible cause and recommended solution
<b>1. POWER</b> gateway or node does not turn on	<b>1.1 node or gateway power is off</b> The status indicator LED on the device may be off. Turn the device on, and the status indicator LED should illuminate.
	<b>1.2 wrong power supply or voltage</b> Using a power supply other than the one specified for the device (or an external supply that is outside of the device operating range) could result in permanent damage to the device or cause it to not work properly.
	<b>1.3 node battery is dead</b> If the node will not power on, the node battery may need to be replaced.
	<b>1.4 sensors are drawing too much current</b> The node battery can only supply a limited amount of power to the connected sensors. If an over-current condition occurs, the node will shut down. This may occur if the sensors are wired wrong.
	<b>1.5 node or gateway is damaged</b> If all power settings and connections have been verified, and the node is still unresponsive, contact LORD Sensing Technical Support ( <a href="#">See Technical Support on page 81</a> ).
<b>2. COMMUNICATION</b> no communication to the gateway or node	<b>2.1 node or gateway has no power</b> Verify the node and gateway have power applied and that applicable power switches are on. Power is indicated on both devices by a status indicator LED.
	<b>2.2 gateway has no communication with the computer</b> Verify gateway communication in the software. Check, remove, and reconnect communications and power cables as applicable.
	<b>2.3 node cannot be configured</b> Observe the node status indicator LED to determine the device's state: boot, idle, sample, or sleep. If the node is sampling or sleeping, it cannot be configured. In SensorConnect, execute the Set to Idle command to put the node in idle state, allowing configuration to occur. If the user inactivity timeout is set very low, the configuration menu will have to be entered quickly, before the timeout occurs, putting the node back in a sample or sleep state.
	<b>2.4 node is out of range</b> Perform a bench test with the node in close proximity to the gateway to verify they are operational. For range test and installation recommendations <a href="#">See Range Test on page 35</a> . The system has been tested to operate with the node and gateway up to 2 km apart with clear line of sight.

	Possible cause and recommended solution
	<p><b>2.5 node is not in normal boot mode</b></p> <p>If the node status indicator shows the node booting in a mode other than the normal boot mode, it can be bypassed by cycling the node power rapidly three times, then leaving it on for normal power up. In normal boot mode the communication can be established with automatic node discovery (or manually) once the boot process is complete and the node is in idle state. Start-up mode can then be changed in the software.</p>
	<p><b>2.6 node is sampling</b></p> <p>Observe the node status indicator LED to determine the device's state: boot, idle, active, or sleep. If the node is sampling, it cannot be configured. In SensorConnect, execute the Set to Idle command to put the node in idle state, allowing configuration to occur.</p>
	<p><b>2.7 node is sleeping</b></p> <p>Observe the node status indicator LED to determine what state it is: boot, idle, active, or sleep. If the node is sleeping, it cannot be configured. In SensorConnect, execute the Set to Idle command to put the node in idle state, allowing configuration to occur.</p>
	<p><b>2.8 gateway or node is damaged</b></p> <p>Verify all connections, power, and settings. If available, try installing alternate nodes and gateways one at a time to see if the faulty device can be identified. If no conclusion can be determined or to send a device in for repair, contact LORD Sensing Technical Support (<a href="#">See Technical Support on page 81</a>).</p>
<p><b>3. DATA ACQUISITION</b></p> <p>sensor data is missing or incorrect</p>	<p><b>3.1 no communication to node or gateway</b></p> <p>Verify connections and power to the node and gateway. Verify they are powered on and communicating with the software. Enter a configuration menu to verify that the node can be accessed.</p>
	<p><b>3.2 sampling settings are incorrect</b></p> <p>If the sampling mode, rate, or duration are not performing as expected, enter the node configuration menu, and verify the sampling settings.</p>
	<p><b>3.3 sampling has not started</b></p> <p>If sampling is occurring, the sampling mode will be displayed next to the node name in SensorConnect. The node device status indicator will also be flashing the sampling mode code. If the node is not sampling, activate it in the software or with a sample on start up boot sequence.</p>
	<p><b>3.4 sensor is not connected correctly</b></p> <p>Verify sensors connections and wiring. For non-standard</p>

	Possible cause and recommended solution
	connections contact LORD Sensing Technical Support ( <a href="#">See Technical Support on page 81</a> ).
	<b>3.5 sensor channel not configured correctly</b> Verify that the sensor is configured on the correct channel and has been enabled for data acquisition.
	<b>3.6 sensor calibration is invalid</b>

## 9.2 Using the Node Tester Board

The node tester board is used to verify node and network functions before sensors are connected, or for diagnostic purposes. The node tester board is used only on differential input channels, and provides a fixed load so system functions can be verified including basic operations not related to the sensor, such as communication and sampling. A fixed load is applied to the differential input by pressing the load button.

There are various impedance value node tester boards available, depending on the node it is being used with. [See \*Wireless Equipment on page 83\*](#) for configuration options and part numbers. Each is configurable to emulate full, half and quarter bridge strain gauges. [Table 9 - Tester Board Configuration](#) describes the strain gauge load settings available. This setting must match the type of node channel that is being tested. For example if the node is a quarter-bridge node, the setting on the tester board must be the same. The configuration chart is also printed on the underside of the board.

### NOTE

The switches may come with a protective film covering them. Simply peel the film off to access the switches.

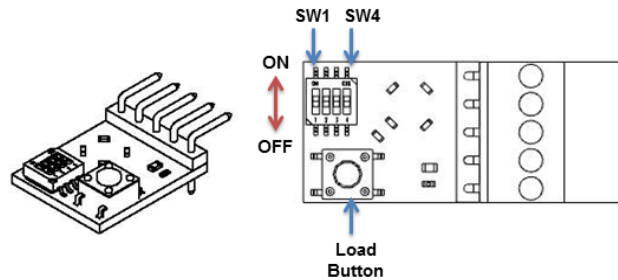

Configuration	SW 1 position	SW 2 position	SW 3 position	SW 4 position
Full Bridge	ON	ON	ON	OFF
Half Bridge	ON	OFF	OFF	OFF
Quarter Bridge	OFF	OFF	OFF	ON

Table 9 - Tester Board Configuration

The following steps describe an example of how to use the tester board to sequence through the primary functions of the node and the wireless system. If the results indicated in the final steps are achieved, the system is fully operational for measuring a full bridge strain gauge. Other scenarios can be tested as needed.

1. Set the jumpers for Full Bridge operation, using a small flat head screw driver to fully push the switch into the desired position.
2. Verify the node is powered off and unplugged.
3. Plug the node tester board into the node **Channel 1** position.

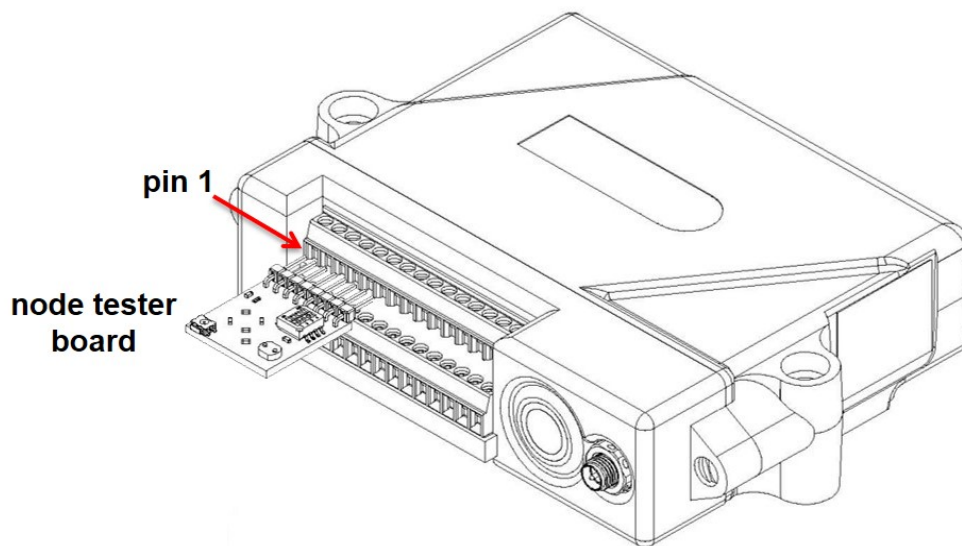

**Figure 53 - Node Tester Board Installation**

4. If not already completed, set up the Wireless Sensor Network equipment and install the SensorConnect software. [See System Operation on page 14.](#)
5. Launch the SensorConnect software, and establish communications with the gateway and node.



6. Select Hardware > Input Range for channel 1, select +/-2 mV from the drop down menu.
7. Under Hardware Offset, select Balance Target for channel 1, select Mid (50%) from the drop down menu.
8. Select Auto-Balance. When auto-balance is complete, a blue information window will indicate the balance result.

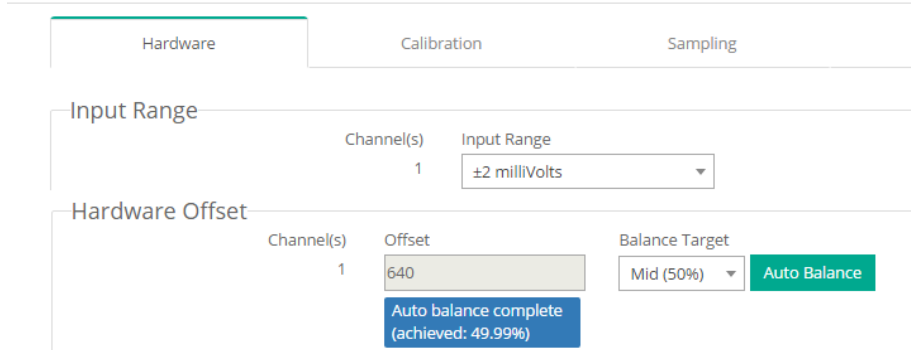

Figure 54 - Auto-Balance

9. Select Calibration.
10. Select Microstrain from the Unit drop down menu, select the Shunt Cal button enabled on the right.

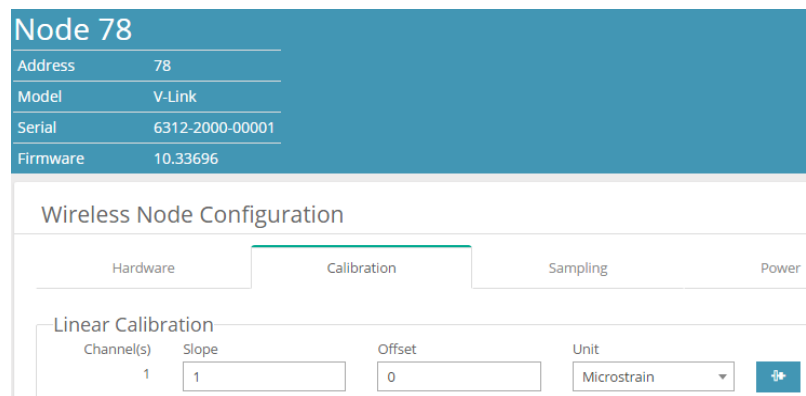

Figure 55 - Node Configuration Menu

11. Use the following settings:
  - a. **Calibration Mode:** Internal
  - b. **Number of Active Gauges:** 4
  - c. **Gauge Factor:** 2
  - d. **Gauge Resistance:** 1000
  - e. **Shunt Resistance:** 499000
12. Select Start Shunt Cal for Slope and Offset calibrations.
13. Select Accept Calibration.

---

Shunt Calibration

---

Node: 78 - Channel: ch1 Slope

Calibration Mode  Offset

# Active Gauges  **Start Shunt Cal**

Gauge Factor

Gauge Resistance

Shunt Resistance

Simulated Strain  **Accept Calibration**

**Figure 56 - Channel Settings**

14. When the calibration is complete, the Wireless Node Configuration window will appear.
15. Select Apply Configuration to write to node memory.
16. In the Wireless Node Configuration window, select the Node heading and then select Sampling.
17. From the Wireless Network menu, select the drop down menu for channel 1 under Sampling > uncheck Continuous streaming, and check For to select a duration of +/- 10 seconds using the arrows to the right of the box, or by typing the number 10 in the box. (the system will auto set to 10.15625).
18. Select Apply and Start Network.

## Wireless Network

Network Settings:  Synchronized  Lossless  High Capacity

<input checked="" type="checkbox"/>	Node	Channels	Sampling	Data Type	Log/Transmit	% Total	Status
<input checked="" type="checkbox"/>	78	1 Channel	128 Hz for 10.156 seconds	float (4 bytes)	Transmit Only	6.25%	✔ Started Sampling

Sample at: 128 Hz

continuously

for: 10.15625 Seconds

Apply and Start Network

Figure 57 - Node Sampling Menu

19. As soon as Apply and Start Network is selected, the node will start collecting data for a duration of +/- 10 seconds. During that time, press and release the load button on the node tester board to shunt the resistive load on and off. Verify the result is as shown in the figure below. The pulse value should equal tester board ohm value. Testing is complete.

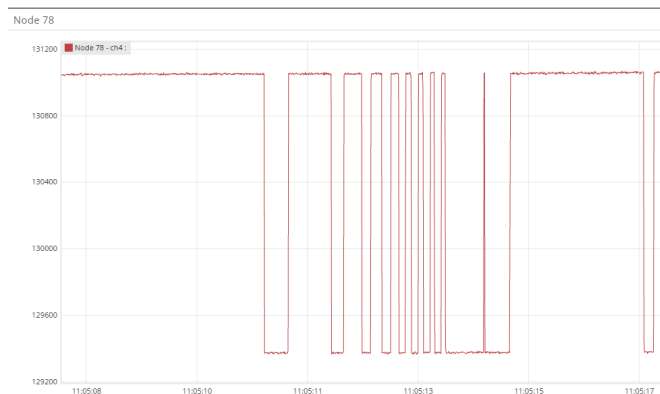

Figure 58 - Node Tester Output Stream

### 9.3 Updating Node Firmware

Under the recommendation of LORD Sensing Technical Support Engineers, nodes can be upgraded to the latest available firmware to take advantage of new features or correct operating issues. SensorConnect version 5.0.0 or greater can be used to update any mXRS or LXRS node or gateway firmware to the most current version. Updates are found on the LORD Sensing website. [See Technical Support on page 81](#) for contact and website information.

1. Download the Firmware Upgrade file from the LORD Sensing website.

2. Once downloaded, extract the contents of the .zip file into a folder on the computer. Verify there is a file with a .zhex extension.
3. Launch SensorConnect, and establish communication between the node and gateway as normal.
4. Select the Node address > Upgrade Firmware > select Browse > select the Firmware Upgrade file > Start Upgrade

## 9.4 Repair and Calibration



### General Instructions

In order to return any LORD Sensing product, you must contact LORD Sensing Sales or Technical Support to obtain a Return Merchandise Authorization number (RMA). All returned merchandise must be in the original packaging including manuals, accessories, cables, etc. with the RMA number clearly printed on the outside of the package. Removable batteries should be removed and packaged in separate protective wrapping. Please provide the LORD Sensing model number and serial number as well as your name, organization, shipping address, telephone number, and email. Normal turn-around for RMA items is seven days from receipt of item by LORD Sensing.



### Warranty Repairs

LORD Sensing warrants its products to be free from defective material and workmanship for a period of one (1) year from the original date of purchase. LORD Sensing will repair or replace, at its discretion, a defective product if returned to LORD Sensing within the warranty period. This warranty does not extend to any LORD Sensing products which have been subject to misuse, alteration, neglect, accident, incorrect wiring, mis-programming, or use in violation of operating instructions furnished by us. It also does not extend to any units altered or repaired for warranty defect by anyone other than LORD Sensing.



### Non-Warranty Repairs

All non-warranty repairs/replacements include a minimum charge. If the repair/replacement charge exceeds the minimum, LORD Sensing will contact the customer for approval to proceed beyond the minimum with the repair/replacement.

### Technical Support

There are many resources for product support found on the LORD Sensing website, including technical notes, FAQs, and product manuals.

<http://www.microstrain.com/support/documentation>

For further assistance our technical support engineers are available to help with technical and applications questions.

### Technical Support

[sensing\\_support@LORD.com](mailto:sensing_support@LORD.com)

**Phone:** 802-862-6629

**Fax:** 802-863-4093

9:00 AM to 5:00 PM (Eastern Time US & Canada)

**SKYPE:** [microstrain.wireless.support](https://www.skype.com/join/microstrain.wireless.support)

Live Chat is available from the website during business hours:

9:00 AM to 5:00 PM (Eastern Time US & Canada)

## 9.5 Maintenance

The replaceable batteries are the only user serviceable parts in the V-Link-200. For instructions on how to change the batteries, [See \*Replacing Batteries on page 91\*](#).

For other service or repair needs contact LORD Sensing Technical Support ([see \*Technical Support on page 81\*](#)).

## 10. Wireless Equipment

### 10.1 Standard Nodes

For the most current product information, custom, and OEM options not listed below, refer to the LORD Sensing website or contact the LORD Sensing Sales Department.

Model Number	Description	LORD Sensing Part Number
V-Link-200	<ul style="list-style-type: none"> <li>• Four differential channels</li> <li>• Four single ended channels</li> <li>• Internal temperature sensor</li> </ul>	6312-2000

#### Configuration Options (Required for use. Specify at time of order)

- **Full-bridge configuration** on one or more differential channels.
- **120Ω, 350Ω or 1000Ω half-bridge** completion on one or more differential channels.
- **120Ω, 350Ω or 1000Ω quarter-bridge** completion on one or more differential channels.
- **High g-force** option. Node operates in gravitational forces in excess of 550 g.

### 10.2 Node Accessories

The following parts are available for use with the V-Link-200. For the most current product information, custom, and OEM options not listed below, refer to the LORD Sensing website or contact the LORD Sensing Sales Department [See Product Ordering on page 85](#)

Description	LORD Sensing Part Number
120Ω node tester board	3042-0062
350Ω Node tester board	3042-0061
1KΩ Node tester board	3042-0060
Lithium AA cell battery 2.4 Ah capacity	9021-0034
Standard whip antenna (FCC compliant)	9010-0048

Table 10 - Node Accessories

### 10.3 Recommended Sensors

Many sensors can be used with the V-Link-200. The following sensors are supported for use with the V-Link-200 and are available from LORD. For help with other sensor applications, [see Technical Support on page 81](#).

Model	Description	LORD Sensing Part Number
ACCEL TRIAX-50	Triaxial Accelerometer, +/-50g	6402-0320
ACCEL-TRIAX-100	Triaxial Accelerometer, +/-100g	6402-0120
ACCEL-TRIAX-200	Triaxial Accelerometer, +/-200g	6402-0220
ACCEL-TRIAX-500	Triaxial Accelerometer, +/-500g	6402-0420

Table 11 - LORD Sensing Sensors



## 10.4 Wireless System Equipment

The following system parts are available for use with the V-Link-200. For the most current standard, custom, and OEM product options, refer to the LORD Sensing website or contact the LORD Sensing Sales Department.

Model	Description	LORD Sensing Part Number
--	SensorConnect Software	8220-0023
WSDA-2000	USB & Ethernet-based Gateway	6314-2000
WSDA-200-USB	USB Gateway	6307-2040
WSDA-BASE-101	Analog Output Gateway	6307-1010
WSDA-BASE-102	RS232 Serial Output Gateway	6307-1020
WSDA-BASE-102-SK	RS232 Gateway Starter Kit.	6307-1021
WSDA-BASE-101-SK	Analog Gateway Starter Kit	6307-1011
--	Replacement USB cable	9022-0029
--	USB Gateway cable extender	6307-0900
--	Replacement serial cable	4005-0005
G-Link-200	Wireless Accelerometer Node	various models
G-Link-LXRS	Wireless Accelerometer Node	various models
SG-Link-LXRS	Wireless 2-Channel Analog Input Sensor Node	various models
SG-Link-OEM	Wireless 2-Channel Analog Input Sensor Node	various models
V-Link-200	Wireless 8 Channel Analog Input Sensor Node	various models
V-Link-LXRS	Wireless 7-Channel Analog Input Sensor Node	various models
TC-Link-LXRS	Wireless Thermocouple Node	various models
DVRT-Link-LXRS	Wireless Displacement Sensor Node	various models
IEPE-Link -LXRS	Wireless IEPE Accelerometer Node	various models

**Table 12 - Wireless System Equipment**

## Product Ordering

Products can be ordered directly from the LORD Sensing website by navigating to the product page and using the Buy feature.

<http://www.microstrain.com/wireless>

For further assistance, our sales team is available to help with product selection, ordering options, and questions.

## Sales Support

[sensing\\_sales@LORD.com](mailto:sensing_sales@LORD.com)

**Phone:** 802-862-6629

**Fax:** 802-863-4093

9:00 AM to 5:00 PM (Eastern Time US & Canada)

## 11. Specifications

### 11.1 Physical Specifications

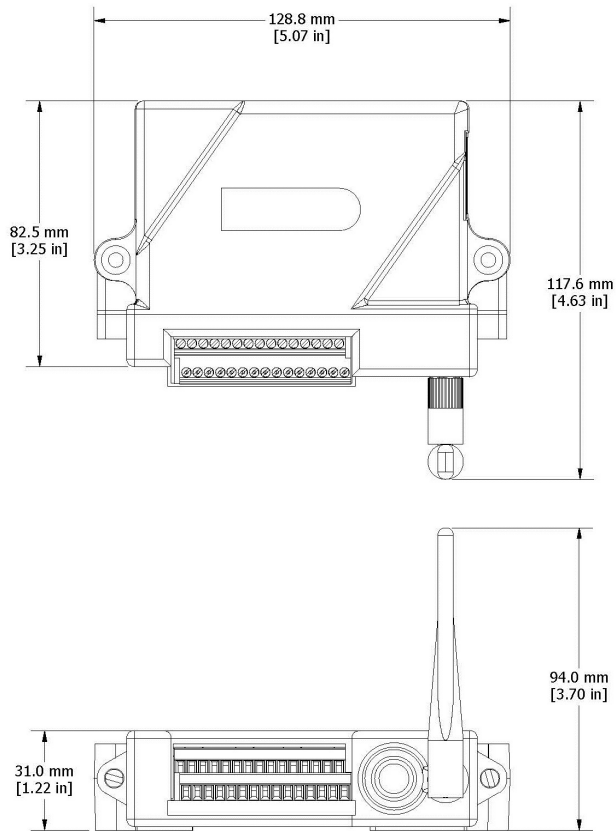

**Dimensions:** 128.8 mm x 82.5 mm x 31.0 mm

**Weight:** 283 grams (with batteries), 217 (without batteries)

**Enclosure Environmental Rating:** General purpose indoor

**IP67/NEMA4X Enclosure Dimensions:** 177.8 mm x 127 mm x 152.4 mm

**Mounting:** 4 x #8-32 UNC-2B

**Weight:** 1347.5 grams (with 3 D-cell batteries)

## 11.2 Operating Specifications

Parameter	Specifications
<b>General</b>	
Sensor input channels	<b>Differential analog</b> , 4 channels <b>Single-ended analog</b> , 4 channels
Integrated sensors	<b>Internal temperature</b> , 1 channel
Data storage capacity	16 M Bytes ( 5+ million data points)
Selectable measurement ranges	Differential: $\pm 1.22$ mV dc to 156 mV dc Single-ended: $\pm 2.56$ V dc, $\pm 5.12$ V dc, $\pm 10.24$ V dc, 0 to 5.12 V dc, 0 to 10.24 V dc
Single-ended input impedance	1 Mohm
Input bandwidth	DC-4000 Hz (-3 dB cutoff)
ADC Resolution	18 bit
Accuracy	
Noise	$\pm 0.02$ % full scale
Temperature stability	< 0.1 % full scale over temperature range
Anti-aliasing filter	Differential Inputs : 128 Hz to 4 kHz, 2nd order Butterworth Single-ended Inputs: -3 dB at 15 kHz
<b>Integrated Temperature Channel</b>	
Measurement range	-40 °C to 85 °C
Accuracy	$\pm 1$ °C (at 25 °C) typical
Resolution	0.1 °C
<b>Sampling</b>	
Sampling modes	Synchronized, low duty cycle, datalogging, event-triggered
Sampling rates	Continuous sampling: 1 sample/hour to 4 KHz * Periodic burst sampling: 32 Hz to 8 KHz *
Sample rate stability	$\pm 5$ ppm
Network capacity	Up to 127 nodes per RF channel depending on settings. See: <a href="http://www.microstrain.com/configure-your-system">http://www.microstrain.com/configure-your-system</a>
Synchronization between nodes	$\pm 50$ $\mu$ sec
<b>Operating Parameters</b>	
Wireless communication range	Outdoor/line-of-sight: 1.5 km ( ideal), 800 m (typical)** Indoor/obstructions: 250 m (typical)**
Radio frequency (RF) transceiver carrier	License-free 2.405 to 2.480 GHz with 16 channels
RF communication protocol	IEEE 802.15.4, FSK/GMSK
RF transmit power	User-adjustable from 0 dBm to 20 dBm. Power output restricted regionally to operate within legal requirements
RF receive sensitivity	-99.4 dBm
RF transmission rate	250 kbps
Power source	Internal: +6.0 to +18.9 V dc - (4) 3.6 V dc, 2.4 Ah Lithium batteries External: +7.5 to 36.0 V dc
Operating temperature	-40 °C to + 85 °C
Acceleration limit	100 g
<b>Physical Specifications</b>	
Dimensions	129 mm x 82.5 mm x 31 mm
Weight	283 grams (with batteries), 217 grams (without batteries)
Environmental rating	Indoor use
Enclosure material	Molded polycarbonate
<b>Integration</b>	
Mounting	Bolt down or DIN-rail mount
Compatible gateways	All WSDA base stations and gateways
Software	SensorCloud, SensorConnect™, Windows 7 (or newer)
Software development kit (SDK)	Open-source MicroStrain Communications Library (MSCL) with sample code available in C++, Python, and .NET formats

Parameter	Specifications
Regulatory compliance	FCC (U.S.), IC (Canada), MIC (Japan), CE (European Union), ROHS

\* Divide maximum rate by number of active channels \*\* Line of sight with antenna at 3 meters

### 11.3 Radio Specifications

The V-Link-200 employs a 2.4GHz IEEE 802.15.4-compliant radio transceiver for wireless communication. The radio is a direct-sequence spread spectrum radio and can be configured to operate on 16 separate frequencies ranging from 2.405 GHz to 2.480 GHz. Following the 802.15.4 standard, these frequencies are aliased as channels 11 through 26. For all newly manufactured nodes, the default setting is 2.425 GHz (channel 15).

For standard models, radiated transmit power is programmable from 4 dBm (2.5 mW) to 16 dBm (40 mW). A low-transmit power option is available (for use in Europe and elsewhere) and is limited to 10 dBm (10 mW).

#### FCC ID: XJQMSLINK0004 V-Link-200

This device complies with Part 15 of the United States FCC Rules, and Industry Canada's license-exempt RSSs. Operation is subject to the following two conditions: 1) This device may not cause interference, and 2) This device must accept any interference, including interference that may cause undesired operation of the device. Changes or modifications, including antenna changes not expressly approved by LORD Corporation could void the user's authority to operate the equipment.

Cet appareil est conforme à la Partie 15 des Règles de la FCC des États-Unis et aux RSSS exempts de licence d'Industrie Canada. Le fonctionnement est soumis aux deux conditions suivantes: 1) Cet appareil ne doit pas causer d'interférences et 2) Cet appareil doit accepter toute interférence, y compris les interférences pouvant entraîner un fonctionnement indésirable de l'appareil. Les changements ou modifications, y compris les changements d'antenne non expressément approuvés par LORD Corporation, pourraient annuler l'autorisation de l'utilisateur d'utiliser l'équipement.

### 11.4 Frequency Setting

#### NOTE

- The gateway can automatically manage nodes operating on different frequencies by using the Node Discovery feature in SensorConnect. In this routine, the gateway listens for node broadcasts on the frequency channel to which it is set. If the node is in normal boot-up mode, it will provide the

broadcast when it is initially powered-on, and it will broadcast on all channels. As long as the node is powered-on after activating the Node Discovery feature, the gateway will link to it and remember the channel setting for future node queries.

- Manually matching the node and gateway frequency channels is required in some applications. For example, when sending broadcast messages from the gateway to multiple nodes (including the synchronized sampling beacon) all nodes must be on the same channel as the gateway in order to receive the broadcast. Assigning channels is also a good idea when multiple gateways are attached to one host computer or when other wireless equipment is nearby and frequency or transmission interference may occur.

## 12. Safety Information

This section provides a summary of general safety precautions that must be understood and applied during operation and maintenance of components in the LORD Sensing Wireless Sensor Network. Throughout the manual, ANSI Z535 standard safety symbols are used to indicate a process or component that requires cautionary measures.

### 12.1 Replacing Batteries

1. Remove the screws on both sides of the face plate to open the V-Link-200.
2. **It is important to replace all four of the batteries at the same time**, observing the correct polarity orientation. The positive polarities are indicated on the batteries and the node by a "+" symbol.
3. Reassemble.

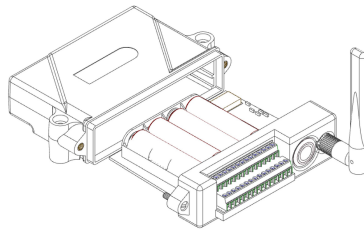

Figure 59 - Replace Batteries

### 12.2 Battery Hazards

**WARNING** **CAUTION** **NOTICE**



The V-Link-200 contains internal, non-rechargeable lithium batteries. Lithium batteries are a fire and explosion hazard. Do not store or operate the node at temperatures above 212°F (100°C). Do not disassemble, short circuit, crush, puncture, or otherwise misuse the battery.



Lithium batteries contain toxic chemicals that are harmful to humans and the environment. Disposal is subject to federal and local laws. Do not discard the battery or the node in the trash. Follow proper battery disposal protocol, or contact LORD Sensing Technical Support for information on extracting the battery or returning the product for proper recycling and disposal.



### 12.3 Power Supply

**⚠ WARNING** **⚠ CAUTION** **NOTICE**



Apply only the input voltage range specified for the V-Link-200 . Connect to a power source that is near the device, is accessible, and adheres to all national wiring standards. Compliance with wiring standards is assumed in the installation of the power source and includes protection against excessive currents, short circuits, and ground faults. Failure to do so could result in personal injury and permanent damage to the device.

### 12.4 Disposal and Recycling

**⚠ WARNING** **⚠ CAUTION** **NOTICE**



The V-Link<sup>®</sup>-200 contains internal batteries, printed circuit boards, and electronic components. These items are known to contain toxic chemicals and heavy metals that are harmful to humans health and the environment. Disposal is subject to federal and local laws. Do not discard the device or batteries in the trash. Follow proper electronic and battery waste disposal protocol, as dictated by federal and local authorities. Some states have programs for extracting reusable parts for recycling.



## 13. References

### 13.1 Related Documents

Many references are available on the LORD Sensing website including product user manuals, technical notes, and quick start guides. These documents are continuously updated, and new applications are added. They may provide more accurate information than printed or file copies.

Document	Where to find it
Online Wireless Network Calculator	<a href="http://sensorcloud.com/?onlyCalc=true">http://sensorcloud.com/?onlyCalc=true</a>
SensorCloud Overview	<a href="http://www.sensorcloud.com/">http://www.sensorcloud.com/</a>
SensorCloud Pricing	<a href="http://sensorcloud.com/pricing">http://sensorcloud.com/pricing</a>
MathEngine® Overview	<a href="http://www.sensorcloud.com/mathengine">http://www.sensorcloud.com/mathengine</a>
SensorConnect Overview & Download	<a href="http://www.microstrain.com/software/sensorconnect">http://www.microstrain.com/software/sensorconnect</a>
LORD Sensing Wireless Sensors Network Software Development Kit	<a href="https://github.com/LORD-MicroStrain/SensorCloud">https://github.com/LORD-MicroStrain/SensorCloud</a>
Product Datasheets	<a href="http://www.microstrain.com/wireless/sensors">http://www.microstrain.com/wireless/sensors</a>
Product Manuals and Technical Notes	<a href="http://www.microstrain.com/support/documentation">http://www.microstrain.com/support/documentation</a>
Product Application Notes	<a href="http://www.microstrain.com/applications">http://www.microstrain.com/applications</a>
NIST Calibration Procedures	<a href="http://www.nist.gov/calibrations/">http://www.nist.gov/calibrations/</a>
ASTM Testing Procedures	<a href="http://www.astm.org/Standard/standards-and-publications.html">http://www.astm.org/Standard/standards-and-publications.html</a>

Table 13 - Related Documents

## 14. Glossary

These terms are in common use throughout the manual:

**A/D Value:** the digital representation of the analog voltages in an analog-to-digital (A/D) conversion. The accuracy of the conversion is dependent on the resolution of the system electronics; higher resolution produces a more accurate conversion. Also referred to as "bits".

**Base Station:** The base station is the transceiver that attaches to the host computer and provides communication between the software and the node(s). It is also referred to as a gateway.

**Burst Sampling:** a mode of operation in which the node is sampled for a fixed window of time (burst) and then repeats that window at set intervals. The burst duration and time between bursts is configurable. Also referred to as periodic burst sampling.

**Calibration:** to standardize a measurement by determining the deviation standard and applying a correction (or calibration) factor

**Configuration:** a general term applied to the node indicating how it is set up for data acquisition. It includes settings such as sampling mode/rate, number of active channels, channel measurement settings, offsets, hardware gain, and calibration values.

**Continuous Sampling:** a mode of operation in which the node is sampled continuously until stopped or sampled continuously for a fixed amount of time

**Coordinated Universal Time (UTC):** the primary time standard for world clocks and time. It is similar to Greenwich Mean Time (GMT).

**Cycle Power:** a command transmitted to the node to reboot it either through a hardware or software switch

**Data Acquisition:** the process of collecting data from sensors and other devices

**Data Logging:** the process of saving acquired data to the system memory, either locally on the node or remotely on the host computer

**DHCP (network):** Dynamic Host Configuration Protocol is the standardized networking protocol used on Internet Protocol (IP) networks, which automatically configures devices that are attached to it by assigning and configuring the device IP address.

**EMI:** Electromagnetic Interference is an inductive or radiated disturbance that can create signal degradation on electrical signals, including loss of data.

**ESD:** Electrostatic Discharge is the sudden flow of electricity that can occur between two charged objects of different potential that come in contact or in close proximity of each other. Static electricity is a common source of ESD.

**Event-Based Sampling:** a mode of operation in which the node sampling is started when a sensor measurement value (threshold) is achieved

**Firmware:** the code that is programmed onto a microcontroller or similar device in an embedded system. It includes device operation commands, conditions, memory allocation, and many other tasks.

**Gateway:** The gateway is a transceiver that attaches to the host computer and provides communication between the software and the node(s). It is also known as a base station.

**Host (computer):** The host computer is the computer that orchestrates command and control of the attached devices or networks.

**LED:** Light Emitting Diode is an indicator light that is used in electronic equipment.

**LOS (Line of Sight):** is used in radio communications to describe the ideal condition between transmitting and receiving antennas in a radio network. As stated it means the antennae are in view of each other with no obstructions.

**LXRS:** Lossless Extended Range Synchronized is the proprietary LORD Sensing data communications protocol used in the wireless sensor network.

**Node:** The node is the wireless transceiver to which the sensor (s) is connected, providing communication with the gateway. The G-Link<sup>®</sup> -LXRS<sup>®</sup>, V-Link<sup>®</sup> -LXRS<sup>®</sup>, and SG-Link<sup>®</sup> -LXRS<sup>®</sup> are examples of nodes manufactured by LORD MicroStrain<sup>®</sup>.

**Node Tester Board:** The node tester board is a device designed by LORD MicroStrain<sup>®</sup> that can be plugged into nodes to test their functionality.

**Offset:** When describing a mathematically-linear relationship, the offset is the value where the line that represents the relationship in a graph crosses the  $y$ -axis. The equation of a straight line is:  $y = mx + b$ , where  $x$  is the  $x$ -axis coordinate,  $y$  is the  $y$ -axis coordinate,  $m$  is the slope and  $b$  is the offset.

**Oversampling:** In signal processing, oversampling is a technique used to achieve increased signal resolution and better noise immunity by recording readings at a higher frequency than the output of the device being measured. In analog-to-digital conversion, the higher the oversampling rate, the better the recreated analog signal.

**Packet:** unit of sampled data

**Periodic Burst Sampling:** a mode of operation in which the node is sampled for a fixed window of time (burst) and then repeats that window at set intervals. The burst duration and time between bursts is configurable. Also referred to as burst sampling.

**Ping:** a byte transmitted by the gateway to the node. The node responds by echoing the byte, indicating communication exists between the node and gateway.

**Range Test:** a continuous string of pings used to validate communication between the gateway and the node over distance and obstruction

**Real Time Clock (RTC):** a computer clock that keeps track of the current time

**RFI:** Radio Frequency Interference is a disturbance in an electrical circuit due to electromagnetic induction or radiation.

**RSSI:** Received Signal Strength Indication is a measurement of the transmission power in a radio signal. It is measured in decibels with reference to 1 milliWatt (dBm).

**RS232:** a serial data communications protocol

**Sensor:** a device that physically or chemically reacts to environmental forces and conditions, producing a predictable electrical signal

**Sleep:** a command transmitted to the node to put it into sleep configuration

**Sampling:** the process of taking measurements from a sensor or device

**Sampling Mode:** the type of sampling that is being utilized, such as event-triggered, continuous, or periodic. The nodes have several sampling modes that employ these types of sampling.

**Sampling Rate:** the frequency of sampling

**Slope:** When describing a mathematically linear relationship, the slope is the steepness of the line that represents that relationship on a graph. The equation of a straight line is:  $y = mx + b$ , where  $x$  is the x-axis coordinate,  $y$  is the y-axis coordinate,  $m$  is the slope, and  $b$  is the offset.

**Streaming:** Streaming is a sampling mode in which all active channels (and the sensors attached to them) are measured, and the acquired data is transmitted to the gateway and software. The data is not written to non-volatile memory during streaming. Streaming can either be finite (have a user defined start and end time) or continuous (continued until the power is cycled on the node).

**Synchronized Sampling:** a sampling mode that automatically coordinates all incoming node data to a particular gateway. This mode is designed to ensure data arrival and sequence.

**Transmission rate:** the number of data packets per transmission window, measured in seconds. Depending on the sampling mode and settings it will be between 1 and 64 packets/second.

**Transmission window:** the time allowed for one data transmission at the automatically determined transmission rate

**USB:** Universal Serial Bus is a serial data communications protocol

**WSN:** Wireless Sensor Network describes a distribution of sensors and data acquisition equipment that autonomously monitors environmental characteristics, such as temperature, pressure, and strain.