

# GSD

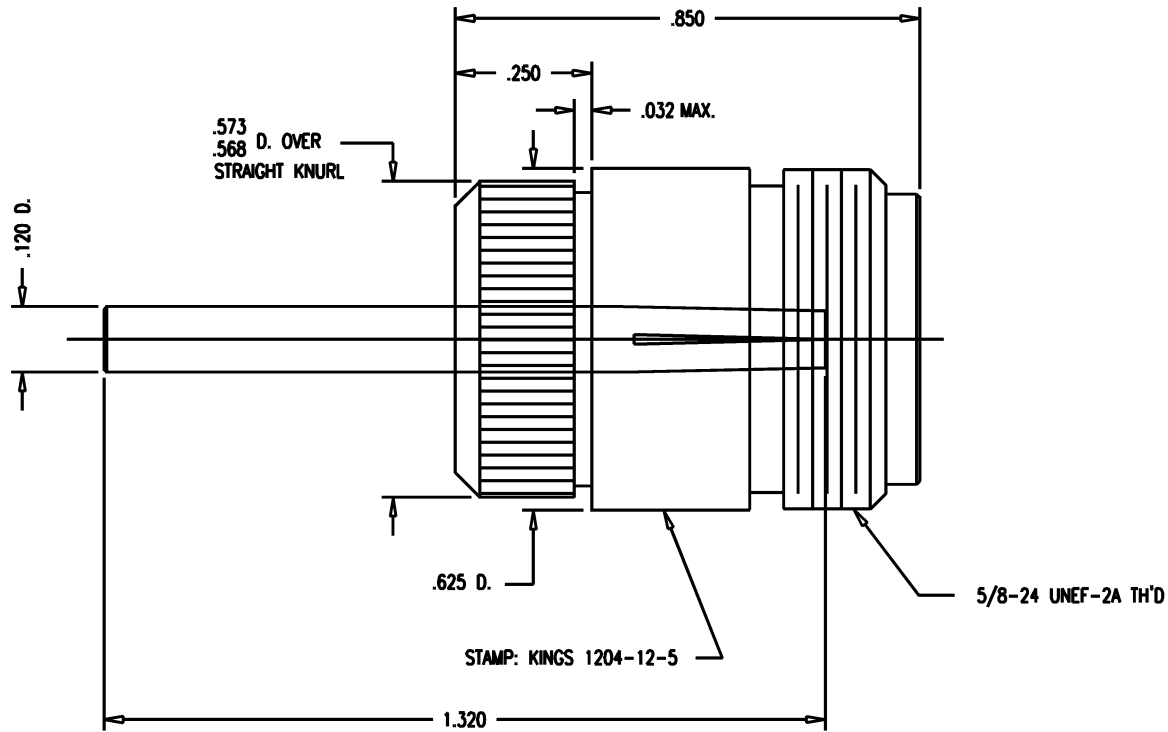

1204-12-5

REVISIONS	
ISSUE	CHANGES
0	ER 33968 KH 07/14/92
1	CN 35204 D MJB 12/07/93
2	CN 35491 C KH 04/14/94
3	CN 35585 A KVH 06/07/94
4	CN 35982 C MJB 02/07/95
5	CN 37220 D KH 02/21/97

**NOTES:**

- CENTER CONTACT TO BE SUPPLIED UNASSEMBLED.
- INTERFACE PER MIL-STD-348, FIG. 304-2.
- MATERIALS:  
INSULATOR-TEFLON, ASTM-D-1457  
CENTER CONTACT-BER. COP., ASTM-B-196  
BODY-BRASS, ASTM-B16
- FINISHES:  
CENTER CONTACT-GOLD PLATE PER MIL-G-45204  
BODY-SILVER PLATE PER QQ-S-365
- ELECTRICAL CHARACTERISTICS:  
NOMINAL IMPEDANCE-50 OHMS  
FREQUENCY RANGE-DC TO 11 GHZ  
WORKING VOLTAGE-1000 VRMS
- WHEN THIS ITEM IS ORDERED BY BARTLEY MACHINE CO.  
PARTS MUST BE SHIPPED IN PARTITION TYPE PACKAGING.  
(WITHOUT INDIVIDUAL BAGS)

SCALE 4:1	
APPROX SURFACE AREA	
WAS: E-17510	
USED ON	
REF:	
RCPT, TYPE "N", (F)	
DRAWN KH	DATE 07/14/92
DESIGN LI	DATE 07/14/92
APPR.	DATE

**KINGS**  
ELECTRONICS CO., INC.  
TUCKAHOE, NEW YORK 10707

1204-12-5

# GSD