

FEATURES

- 12-bit resolution
- No missing codes
- 1MHz minimum sampling rate
- Functionally complete
- Small 24-pin DDIP
- Low-power, 1.3 Watts
- Three-state output buffers
- Samples to Nyquist frequencies

PRODUCT OVERVIEW

DATEL's ADS-112 is a 12-bit, functionally complete, sampling A/D converter that is packaged in a space-saving 24-pin DDIP. Requiring $\pm 15V$ and $+5V$ supplies, a minimum sampling rate of 1MHz is achieved while only dissipating 1.3 Watts. The ADS-112 digitizes signals up to Nyquist frequencies. Models are available for use in either commercial (0 to $+70^{\circ}C$) or military (-55 to $+125^{\circ}C$) operating temperature ranges.

Typical applications include spectrum, transient, vibration and waveform analysis. This device is also ideally suited for radar, sonar, video digitization, medical instrumentation and highspeed data acquisition systems.

INPUT/OUTPUT CONNECTIONS			
PIN	FUNCTION	PIN	FUNCTION
1	BIT 12 (LSB)	24	-15V SUPPLY
2	BIT 11	23	ANALOG GROUND
3	BIT 10	22	+15V SUPPLY
4	BIT 9	21	+10V REFERENCE
5	BIT 8	20	BIPOLAR
6	BIT 7	19	ANALOG INPUT
7	BIT 6	18	COMP BIN
8	BIT 5	17	ENABLE (1-12)
9	BIT 4	16	START CONVERT
10	BIT 3	15	EOC
11	BIT 2	14	DIGITAL GROUND
12	BIT 1 (MSB)	13	+5V SUPPLY

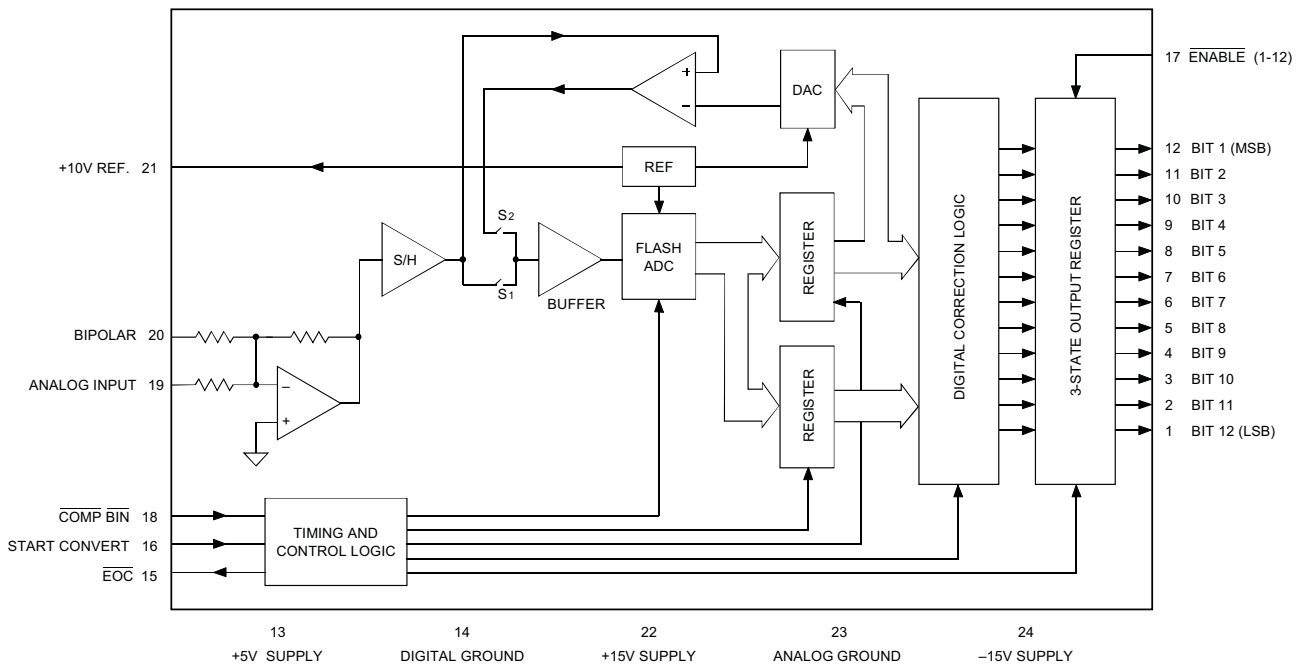

Figure 1. ADS-112 Functional Block Diagram



12-Bit, 1MHz, Low-Power Sampling A/D Converters

ABSOLUTE MAXIMUM RATINGS		
PARAMETERS	LIMITS	UNITS
+15V Supply (Pin 22)	0 to +18	Volts
-15V Supply (Pin 24)	0 to -18	Volts
+5V Supply (Pin 13)	0 to +6	Volts
Digital Inputs (Pin 16, 17, 18)	-0.3 to +VDD +0.3	Volts
Analog Input (Pin 19)	-9 to +15	Volts
Lead Temp. (10 seconds)	+300	°C

Functional Specifications

(TA = +25°C, ±VCC = ±15V, +VDD = +5V, 1MHz sampling rate, and a minimum 1 minute warmup unless otherwise specified.)

ANALOG INPUTS	MIN.	TYP.	MAX.	UNITS
Input Voltage Range ①				
Bipolar	—	±5	—	Volts
Unipolar	—	0 to +10	—	Volts
Input Impedance	4.5	5	—	kΩ
Input Capacitance	—	6	15	pF

DIGITAL INPUTS				
Logic Levels				
Logic "1"	+2.0	—	—	Volts
Logic "0"	—	—	+0.8	Volts
Logic Loading "1"	—	—	+10	μA
Logic Loading "0"	—	—	-600	μA

PERFORMANCE				
Resolution		12 Bits		
No Missing Codes (12 Bits; fin = 1MHz)		Over the operating temperature range		

Integral Non-Linearity				
+25°C	—	±1/4	±3/4	LSB
0°C to +70°C	—	±1/4	±3/4	LSB
-55°C to +125°C	—	±1/2	±1.5	LSB

Differential Non-Linearity				
+25°C	—	±1/4	±3/4	LSB
0°C to +70°C	—	±1/4	±3/4	LSB
-55°C to +125°C	—	±1/2	±1	LSB

Full Scale Absolute Accuracy				
+25°C	—	±0.13	±0.25	%FSR
0°C to +70°C	—	±0.15	±0.44	%FSR
-55°C to +125°C	—	±0.25	±0.78	%FSR

Unipolar Zero Error †				
0°C to +70°C	—	±0.074	±0.265	%FSR
-55°C to +125°C	—	±0.224	±0.43	%FSR

Bipolar Zero Error †				
0°C to +70°C	—	±0.074	±0.166	%FSR
-55°C to +125°C	—	±0.124	±0.210	%FSR

Bipolar Offset Error †				
0°C to +70°C	—	±0.1	±0.38	%FSR
-55°C to +125°C	—	±0.3	±0.60	%FSR

Gain Error †				
0°C to +70°C	—	±0.1	±0.38	%
-55°C to +125°C	—	±0.3	±0.60	%

Internal Reference Voltage, +25°C				
Drift	—	±5	±30	ppm/°C
External Current	—	—	1.5	mA

DYNAMIC PERFORMANCE				
In-Band Harmonics (-0.5dB)				
dc to 100kHz	—	-81	-75	dB
100kHz to 500kHz	—	-75	-70	dB
Total Harm. Distort. (-0.5dB)				
dc to 100kHz	—	-78	-75	dB
100kHz to 500kHz	—	-73	-68	dB

DYNAMIC PERFORMANCE, CONT.	MIN.	TYP.	MAX.	UNITS
Signal-to-Noise Ratio (wo/distort., -0.5dB)				
dc to 100kHz	68	72	—	dB
100kHz to 500kHz	67	71	—	dB
Signal-to-Noise Ratio ② (& distort., -0.5dB)				
dc to 100kHz	66	70	—	dB
100kHz to 500kHz	66	70	—	dB
Two-tone Intermodulation Distortion (fin = 75kHz, 105kHz, fs = 1MHz, -0.7dB)	—	-88	-80	dB
Two-tone Intermodulation Distortion (fin = 480kHz, 490kHz, fs = 1MHz, -0.7dB)	—	-68	-65	dB
Input Bandwidth (-3dB)				
Small Signal (-20dB input)	8	10	—	MHz
Large Signal (-0.5dB input)	6	8	—	MHz
Slew Rate	—	±150	—	V/μs
Aperture Delay Time	—	—	20	ns
Effect. Aperture Delay Time	—	—	16	ns
Aperture Uncertainty (Jitter)				
RMS	—	—	15	ps
Peak	—	—	±50	ps
Overvoltage Recovery Time	—	—	1000	ns
S/H Acquisition Time	160	250	280	ns
Conversion Rate (Changing Inputs)				
+25°C	1	—	—	MHz
0°C to +70°C	1	—	—	MHz
-55°C to +125°C	1	—	—	MHz

DIGITAL OUTPUTS				
Data Coding	Straight binary/Offset binary			
Pin 18 High	Complementary binary			
Pin 18 Low	Complementary offset binary			
Logic Level				
Logic "1"	+2.4	—	—	Volts
Logic "0"	—	—	+0.4	Volts
Logic Loading "1"	—	—	-160	μA
Logic Loading "0"	—	—	+6.4	mA

POWER REQUIREMENTS				
Power Supply Ranges ③				
+15V Supply	+14.25	+15.0	+15.75	Volts
-15V Supply	-14.25	-15.0	-15.75	Volts
+5V Supply	+4.75	+5.0	+5.25	Volts
Power Supply Current				
+15V Supply	—	+24	+35	mA
-15V Supply	—	-40	-48	mA
+5V Supply	—	+80	+95	mA
Power Dissipation	—	1.3	1.7	Watts
Power Supply Rejection	—	—	±0.07	%FSR/V

PHYSICAL/ENVIRONMENTAL				
Operating Temp. Range, Case				
ADS-112MC	0	—	+70	°C
ADS-112MM, 883	-55	—	+125	°C
Storage Temperature Range	-65	—	+150	°C
Package Type	24-pin, metal-sealed, ceramic DDIP			
Weight	0.42 ounces (12 grams)			

① See Table 3 also

② Effective bits is equal to:

$$\text{Effective bits} = \frac{20 \log \left[\frac{\text{Full Scale Amplitude}}{\text{Actual Input Amplitude}} \right] - 1.76}{6.02}$$

③ For ±12V, +5V operation, contact DATEL

† See Tech Note 1

TECHNICAL NOTES

1. Applications which are unaffected by endpoint errors or remove them through software will use the typical connections shown in Figure 3. Remove system errors or adjust the small initial errors of the ADS-112 to zero using the optional external circuitry shown in Figure 4. The external adjustment circuit has no effect on the throughput rate.
2. For best performance, always connect the analog and digital ground pins to a ground plane beneath the converter. The analog and digital grounds are not connected to each other internally.
3. Bypass the analog and digital supplies and the +10V reference (pin 21) to ground with 4.7µF, 25V tantalum electrolytic capacitors in parallel with 0.1µF ceramic capacitors. Bypass the +10V reference (pin 21) to analog ground (pin 23).
4. Obtain straight binary/offset binary output coding by tying COMP BIN (pin 18) to +5V or leaving it open. The device has an internal pull-up resistor on this pin. To obtain complementary binary

- or complementary offset binary output coding, tie pin 18 to ground. The pin 18 signal is compatible with CMOS/TTL logic levels for those users desiring dynamic control of this function.
5. To enable the three-state outputs, connect ENABLE (pin 17) to a logic "0" (low). To disable, connect pin 17 to a logic "1" (high).
 6. Do not change the status of pin 18 when EOC is high.
 7. Re-initiating the START CONVERT (pin 16) while EOC is a logic "1" (high) will result in a new conversion sequence.

TIMING

Figure 2 shows the relationship between the various input signals. The timing shown applies over the operating temperature range and over the operating power supply range. These times are guaranteed by design.

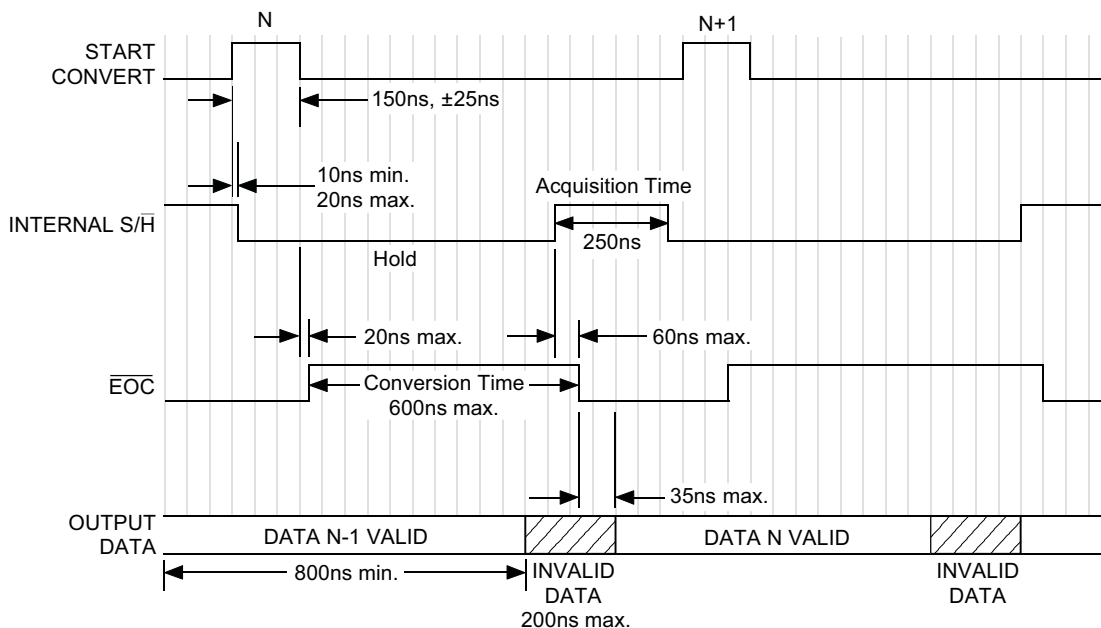

Note: Scale is approximately 50ns per division.

Figure 2. ADS-112 Timing Diagram

CALIBRATION PROCEDURE

1. Connect the converter per Figures 3 and 4 and Tables 1 and 3 for the appropriate input range. Apply a pulse of 150 nanoseconds to the START CONVERT input (pin 16) at a rate of 250kHz. This rate is chosen to reduce the flicker if LED's are used on the outputs for calibration purposes.

2. Zero Adjustments

Apply a precision voltage reference source between the amplifier's analog input and ground. Adjust the output of the reference source per Table 2. For unipolar, adjust the zero trimming potentiometer so that the output code flickers equally between 0000 0000 0000 and 0000 0000 0001 with COMP BIN (pin 18) tied high (straight binary) or between 1111 1111 1111 and 1111 1111 1110 with pin 18 tied low (complementary binary).

For bipolar operation, adjust the potentiometer such that the code flickers equally between 1000 0000 0000 and 1000 0000 0001 with pin 18 tied high (offset binary) or between 0111 1111 1111 and 0111 1111 1110 with pin 18 tied low (complementary offset binary).

3. Full-Scale Adjustment

Set the output of the voltage reference used in step 2 to the value shown in Table 2. Adjust the gain trimming potentiometer so that the output code flickers equally between 1111 1111 1110 and 1111 1111 1111 for pin 18 tied high or between 0000 0000 0001 and 0000 0000 0000 for pin 18 tied low.

To confirm proper operation of the device, vary the precision reference voltage source to obtain the output coding listed in Table 4.

Table 1. Input Range Selection

Input Range	Input Pin	Tie Together
±5v	Pin 19	Pin 20 to Pin 21
0 to +10V	Pin 19	Pin 20 to Ground

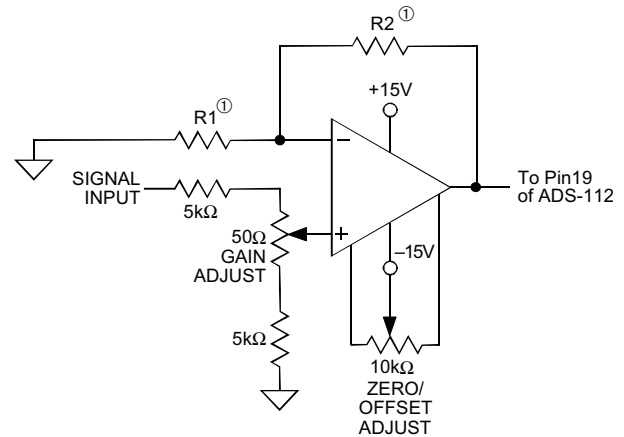

① For values of R1 and R2 refer to Table 3.

Figure 4. Optional Calibration Circuit

Table 2. Zero and Gain Adjust

Input Range	Zero Adjust +1/2 LSB	Gain Adjust +FS - 1 1/2 LSB
0 to +10V	+1.22mV	+9.9963V
±5V	+1.22mV	+4.9963V

Table 3. Input Range (using external calibration)

Input Range	R1	R2	Unit
0 to 10V, ±5	2	2	kW
0 to 5V, ±2.5V	2	6	kW
0 to +2.5V, ±1.25V	2	14	kW

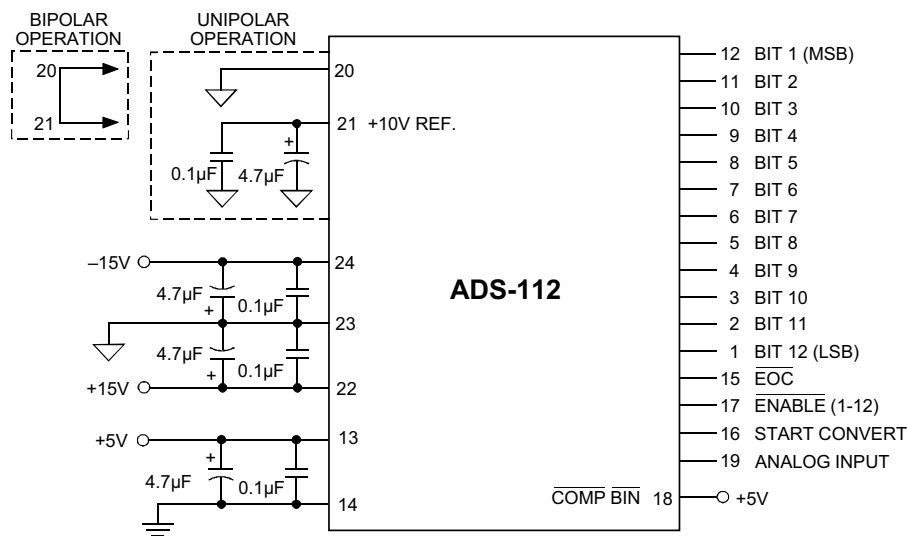

Note: Always bypass pin 21 to ground

Figure 3. Typical ADS-112 Connection Diagram

Table 4. Output Coding

UNIPOLAR SCALE	INPUT RANGE 0 to +10V	STRAIGHT BIN.			COMP. BINARY			INPUT RANGE ±5V	BIPOLAR SCALE
		OUTPUT CODING							
		MSB	LSB		MSB	LSB			
+FS - 1 LSB	+9.9976	1111	1111	1111	0000	0000	0000	+4.9976	+FS - 1 LSB
+7/8 FS	+8.7500	1110	0000	0000	0001	1111	1111	+3.7500	+3/4FS
+3/4 FS	+7.5000	1100	0000	0000	0011	1111	1111	+2.5000	+1/2FS
+1/2 FS	+5.0000	1000	0000	0000	0111	1111	1111	0.0000	0
+1/4 FS	+2.5000	0100	0000	0000	1011	1111	1111	-2.5000	-1/2FS
+1/8 FS	+1.2500	0010	0000	0000	1101	1111	1111	-3.7500	-3/4FS
+1 LSB	+0.0024	0000	0000	0001	1111	1111	1110	-4.9976	-FS+1LSB
0	0.0000	0000	0000	0000	1111	1111	1111	-5.0000	-FS

OFF. BINARY COMP. OFF. BIN.

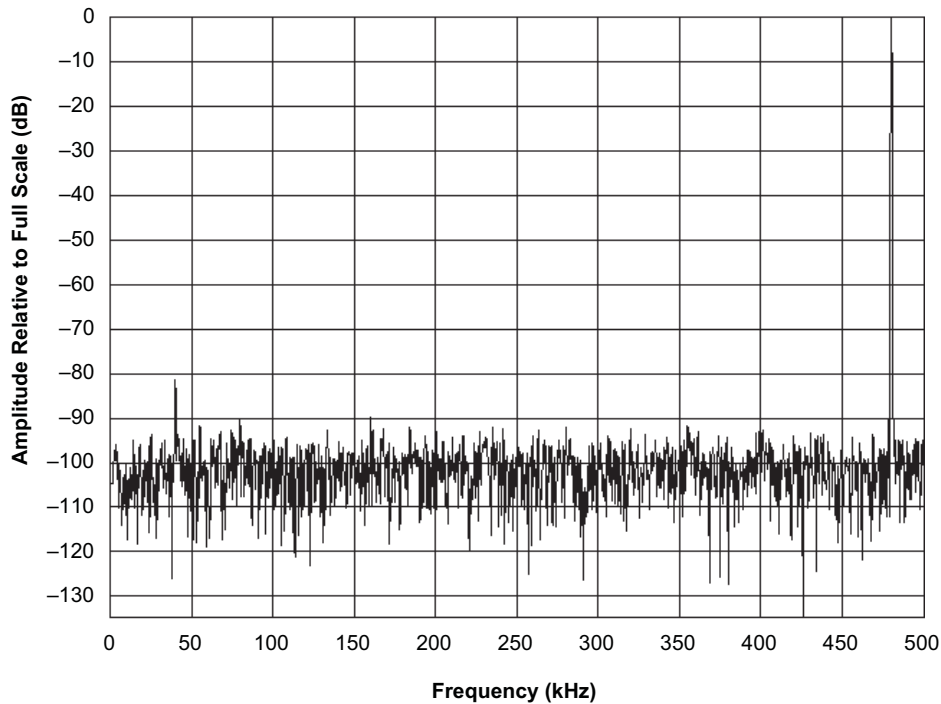

(fs = 1MHz, fin = 485kHz, Vin = -0.5dB, 4,096-point FFT)

Figure 5. FFT Analysis of ADS-112

MECHANICAL DIMENSIONS INCHES (mm)

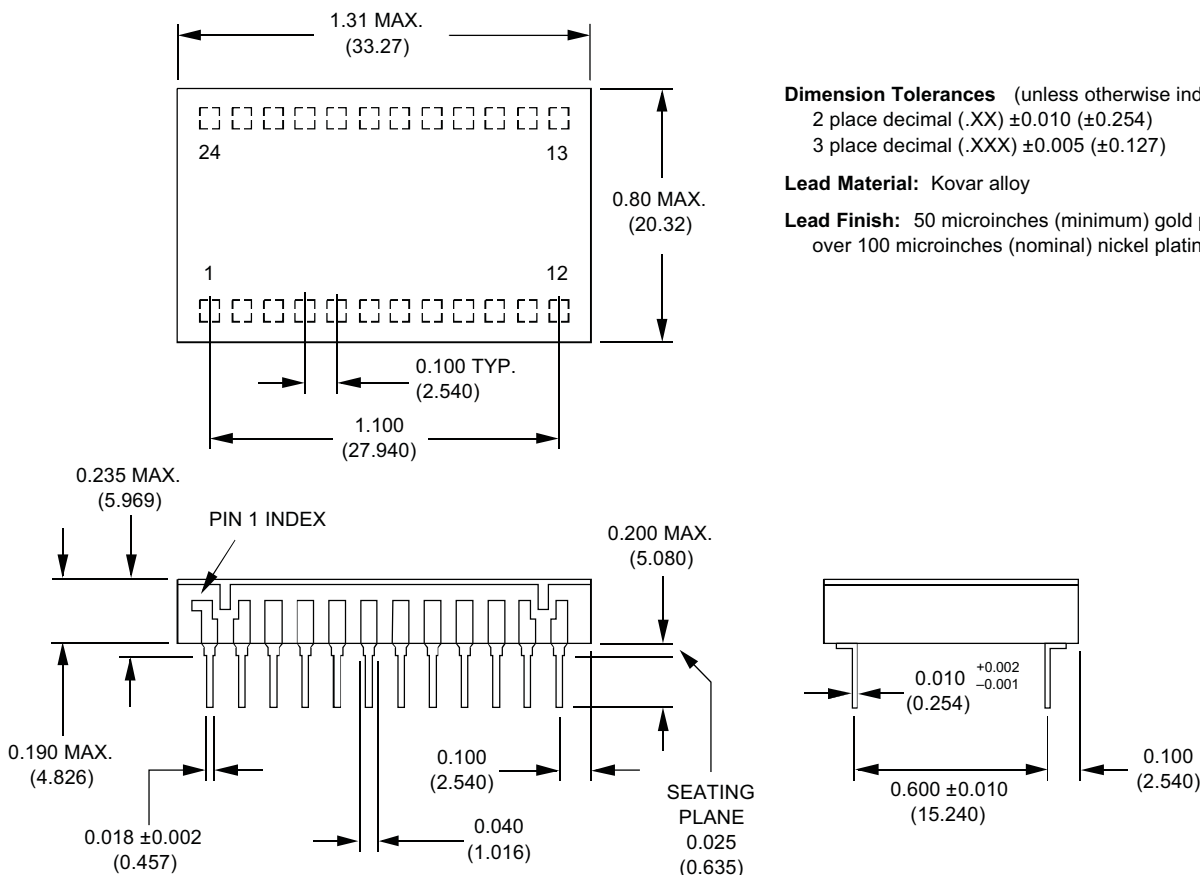

Dimension Tolerances (unless otherwise indicated):
 2 place decimal (.XX) ±0.010 (±0.254)
 3 place decimal (.XXX) ±0.005 (±0.127)

Lead Material: Kovar alloy

Lead Finish: 50 microinches (minimum) gold plating
 over 100 microinches (nominal) nickel plating

ORDERING INFORMATION

MODEL	OPERATING TEMP. RANGE
ADS-112MC	0 to +70°C
ADS-112MM	-55 to +125°C
ADS-112/883	-55 to +125°C
ACCESSORIES	
ADS-EVAL4	Evaluation Board (without ADS-112)
HS-32	Heat Sink for all ADS-112 models