

ATLANTIC VERSION TERMINATOR INTERFACE ADAPTER	PART NUMBER	REVISION	DESCRIPTION	FEED TYPE	APPLICATOR STYLE CONVERSION CHART						
					CONVERT TO	PART NUMBERS REQUIRED					
						PNEUMATIC FEED	2119950-1	2119792-2	-	2119641-1	-
	2150376-1	B	FINE CRIMP HEIGHT ADJUST	MECHANICAL	SERVO LATCH PLATE	2119951-1	1901697-1	8-2150376-5	-	-	2168400-7 (QUANTITY 2)
					SMART APPLICATOR	2161326-1	-	8-2150376-4	-	-	-
					MECHANICAL FEED	2119949-1	2063961-1	5-18022-5	2119653-1	-	-
	2150376-2	B	FINE CRIMP HEIGHT ADJUST	PNEUMATIC	SERVO LATCH PLATE	2119951-1	1901697-1	8-2150376-5	-	-	2168400-7 (QUANTITY 2)
					SMART APPLICATOR	2161326-1	-	8-2150376-4	-	-	-
					MECHANICAL FEED	2119949-1	2063961-1	5-18022-5	2119653-1	-	-
	2150376-5	B	FINE CRIMP HEIGHT ADJUST	SERVO LATCH PLATE	SERVO LATCH PLATE	2119950-1	2119792-2	-	2119641-1	-	2063440-1
					PNEUMATIC FEED	2119950-1	2119792-2	-	2119641-1	-	2063440-1
	2150376-6	B	NON-CRIMP HEIGHT ADJUST	SERVO LATCH PLATE	SERVO LATCH PLATE	-	-	-	-	-	-
					PNEUMATIC FEED	-	-	-	-	-	-
	2150376-7	B	FINE CRIMP HEIGHT ADJUST	NONE	-	-	-	-	-	-	-
	7-2150376-7	B	CRIMP TOOLING KIT	-	-	-	-	-	-	-	-

APPLICATOR DATA		
CRIMP	SIZE	TYPE
WIRE	2.28 mm [.090]	F
INSUL	3.00 mm [.118]	F
APPL INSTRUCTIONS 408-10390		

TERMINAL DATA: TE TERMINAL		TE CRIMP SPECIFICATION	
TERMINAL NAME: L.I.F. POSITIVE LOCK CONTACT 5MM SERIES			
WIRE STRIP LENGTH		INSULATION DIAMETER RANGE	
3.50-4.50 mm [.138-.177 IN]		1.30-2.00 mm [.051-.079 IN]	
TERMINAL APPLICATION SPECIFICATION	114-15008	-	-
TERMINALS APPLIED			
TE TERMINAL	TE TERMINAL	TE TERMINAL	TE TERMINAL
141991-1	141991-3	1-141991-2	142685-3
141991-2	1-141991-1	2-141991-2	

WIRE SIZE	CRIMP HEIGHT mm [INCH]	CRIMP HEIGHT REFERENCE SETTING
0.6+0.35	1.42+/-0.05 [.056+/-0.002]	8.5
1.00mm2	1.42+/-0.05 [.056+/-0.002]	8.5
0.35+0.35	1.35+/-0.05 [.053+/-0.002]	9.4
0.60mm2	1.29+/-0.05 [.051+/-0.002]	10.1
0.35mm2	1.19+/-0.05 [.047+/-0.002]	11.4



- 1. RECOMMENDED SPARE PARTS
- 2. GREASE BEARING SURFACES LIGHTLY
- 3. LUBRICATE DAILY PER THE APPLICATOR INSTRUCTION SHEET SUPPLIED WITH THE APPLICATOR.
- 4. APPLICATOR SPECIFIC DATA TO BE ENTERED INTO BLANK MEMORY CHIP AT ASSEMBLY. SEE BELOW FOR PART NUMBER:
 MECHANICAL FEED WITH "SMART APPLICATOR" CONVERSION: 8-2150376-4
 PNEUMATIC FEED WITH "SMART APPLICATOR" CONVERSION: 8-2150376-4
 SERVO FEED WITH "FINE CRIMP HEIGHT ADJUST": 8-2150376-5
 SERVO FEED WITH "NON-CRIMP HEIGHT ADJUST": 8-2150376-6
- 5. ADJUSTMENT OF THE STRIPPER MAY BE REQUIRED WHEN MOVING THE APPLICATOR BETWEEN BENCH AND LEADMAKER APPLICATIONS.
- 6. APPLY PART NUMBER 1-23419-5 LOCTITE TO THREADS OF ITEMS 50 & 62. APPLY PART NUMBER 2-23419-6 LOCTITE TO THREADS OF ITEM 242. FOR -6 ONLY APPLY PART NUMBER 1-23419-5 LOCTITE TO THREADS OF ITEMS 37 & 50.
- 7. GREASE THREADS, GROOVE AND O-RING ON ITEMS 35 & 252.
- 8. MAGNET, ITEM 166 MUST BE ORIENTED CORRECTLY IN ORDER TO PROPERLY ACTUATE THE COUNTER.
- 9. CRIMP HEIGHT REFERENCE SETTING WAS THE SETTING USED WHEN THE APPLICATOR WAS QUALIFIED AT THE FACTORY. ADJUSTMENT MAY BE NECESSARY WHEN RUNNING APPLICATOR IN THE FIELD.
- 10. SPARE FEED CAM STORAGE LOCATION REFER TO INSTRUCTION SHEET FOR ADDITIONAL INFORMATION.
- 11. THE RECOMMENDED SET-UP FOR END FEED APPLICATORS IS POST-FEED WITH ITEM 2119653-1. THE APPLICATOR CAN BE CONFIGURED FOR PRE-FEED WITH ITEM 2119652-1 BUT MAY ENCOUNTER PROBLEMS WITH SOME APPLICATIONS. FEED ISSUES OR TERMINAL JAMMING MAY OCCUR IN THE PRE-FEED CONFIGURATION.
- 12. WHEN ASSEMBLING -6 NON-CRIMP HEIGHT ADJUST APPLICATOR USE SHIM PACK 2119957-2 TO ALIGN APPLICATOR'S MAXIMUM WIRE CRIMP HEIGHT AT NORMAL TERMINATOR SHUT HEIGHT

***WARNING**
 ON INSTALLATION, SET WIRE DISC, ITEM 40 TO LARGEST WIRE SIZE SETTING. USE OF SETTINGS BELOW MINIMUM REQUIRED CRIMP HEIGHT SETTING WILL CAUSE DAMAGE TO CRIMP TOOLING.

-	-	1	-	-	-	2119957-2	APPLICATOR SHIM PACK	260
-	1	-	1	1	1	8-21084-0	O-RING, .676 ID, .070 DIA. MAT.	252
-	-	-	-	1	-	2119640-1	PUSH ROD, AIR FEED	250
-	-	-	-	1	-	2079988-1	BUSHING, LCH5-12, MISUMI	249
-	-	-	-	1	-	2119641-1	FEED CAM, AIR FEED	248
-	1	-	1	1	1	2119798-1	DETENT PIN	247
-	1	-	1	1	1	1-22279-3	SPRING, COMPRESSION	246
-	-	1	-	-	-	2119759-1	RAM, AMP STYLE, END FEED, NON-ADJUST	245
-	1	1	1	1	1	2119082-9	CAM, SNAIL, INSULATION ADJUSTMENT	244
-	1	1	1	1	1	2079764-1	WASHER, WAVE SPRING, CREST-TO-CREST	243
-77	-7	-6	-5	-2	-1	PART NO	DESCRIPTION	ITEM NO

ATLANTIC VERSION
 Shown on sheets 1 of 4 & 2 of 4
 (Pacific version shown on sheets 3 of 4 & 4 of 4)

SET UP GAUGE	LOC	DIST	REVISIONS			
2119599-2	A	66	REV	DATE	BY	APPD
			A	RELEASED	13NOV2013	BH TE
			B	ECR-15-016679	13NOV2015	KH CT

6	-	1	1	1	1	1	2119083-1	RETAINER, INSULATION DIAL	242
	-	-	2	2	-	-	2168400-7	SHCS, LOW HEAD, RoHS, M5 X 10	240
	-	-	-	-	-	1	2119580-1	MECHANICAL FEED ASSEMBLY	239
	-	-	-	-	1	-	2063440-1	AIR FEED MODULE	238
	-	-	1	1	-	-	2119740-2	TAG, IDENTIFICATION	213
	-	-	REF	REF	-	-	1901697-1	FEED FINGER ASSEMBLY, EF	183
	-	1	1	1	1	1	6-9931111-6	PIN, SLOTTED SPRING 3.0 X 14.0	177
	-	1	1	1	1	1	8-22280-7	SPRING, COMPRESSION	176
	-	1	1	1	1	1	1752353-2	GUIDE PIN, HOLDDOWN	175
	-	1	1	1	1	1	1901680-2	GUIDE PIN, HOLDDOWN	174
	-	-	-	-	2	-	21045-3	RING, RETAIN, EXTERN, 3/16 CRESCENT	172
	-	1	1	1	1	1	994969-1	MAGNET, RARE EARTH HIGH ENERGY	166
	-	REF	REF	REF	REF	REF	994970-2	COUNTER, MAGNETIC	164
	-	-	-	-	1	-	240638-1	SPRING, FEED FINGER	163
	-	-	-	-	1	-	3-23627-7	PIN, RETAIN, GRVD, 3/16 X .854	137
	-	-	REF	REF	-	-	SEE NOTE 4	MEMORY CHIP, PROGRAMMED	135
	-	-	1	1	-	-	1633743-1	SERVO FEED LATCH ASM	133
	-	1	1	1	1	1	455888-5	SPACER, CRIMPER	82
	-	1	1	1	1	1	2119956-2	DOCUMENTATION PACKAGE	71
	-	2	2	2	2	2	2-18032-2	SCR, SET, FLT POINT M3 X 10.0	70
	-	1	-	-	1	1	2119740-1	TAG, IDENTIFICATION	67
	-	2	2	2	2	2	2168078-1	SCREW, DRIVE, RH, RoHS, 2 x .188	66
	-	1	1	1	1	1	1901681-1	HOLDDOWN, TERMINAL	65
	-	2	2	2	2	2	2168083-8	SCR, SKT HD CAP, RoHS, M4 X 16	64
	-	1	-	1	1	1	2119793-1	LIMITER, ADJUSTMENT BOLT	63
6	-	3	-	3	3	3	992763-5	SCR, SET, SOC, CONE POINT, M3 X 4.0	62
	-	1	1	1	1	1	2079383-4	SCR, BHSC, RoHS (M4 X 8)	60
	-	-	-	-	-	1	5-18022-5	SCR, HEX HD CAP, M4 X 6.0	59
	-	-	-	-	-	1	2063961-1	FEED FINGER	58
	-	3	3	3	3	3	2168400-4	SHCS, LOW HEAD, RoHS, M4 X 8	57
	-	2	2	2	2	2	2168083-8	SCR, SKT HD CAP, RoHS, M4 X 16	56
	-	2	2	2	2	2	5018030-2	NUT, HEX, REG, RoHS, M4	55
	-	2	2	2	2	2	5018030-1	NUT, HEX, REG, RoHS, M3	54
	-	2	2	2	2	2	986965-8	NUT, LOCK, HEX, TORQUE (M4)	53
	-	1	1	1	1	1	1-5018030-0	NUT, HEX, REG, RoHS, M3.5	52
	-	-	-	-	1	-	2119792-2	PAWL, EF, AIR	51
6	-	1	1	1	1	1	1-1752354-2	STANDOFF, HOLD-DOWN	50
	-	-	-	-	1	2	18023-9	SCR, SKT HD CAP M4 X 6.0	49
	-	-	-	-	1	-	2119652-1	FEED CAM, PRE FEED	48
	-	-	-	-	1	-	2119653-1	FEED CAM, POST FEED	47
	-	1	1	1	1	1	2119655-5	APPLICATOR BASIC ASSEMBLY, EF	46
	-	1	-	1	1	1	2119369-1	RAM, AMP STYLE, END FEED	44
	-	1	1	1	1	1	2079383-7	SCR, BHSC, RoHS (M8 X 25)	41
	-	1	-	1	1	1	2119645-1	DISC, NUMBERED FA WIRE ADJUSTMENT	40
	-	1	-	1	1	1	2119957-1	APPLICATOR SHIM PACK	39
6	-	1	1	1	1	1	1-2119644-2	RAM WASHER, PRECISION	38
	-	1	1	1	1	1	2119085-1	FA HEAD, ATLANTIC STYLE	37
	-	1	-	1	1	1	2119092-1	BOLT, ADJUSTMENT	35
	-	7	7	7	7	7	1-18028-2	WASHER, FLAT, REG M4	33
	-	1	1	1	1	1	2168083-9	SCR, SKT HD CAP, RoHS, M4 X 20	32
	-	1	1	1	1	1	2168083-8	SCR, SKT HD CAP, RoHS, M4 X 16	31
	-	2	2	2	2	2	1-2168083-0	SCR, SKT HD CAP, RoHS, M4 X 10	29
	-	1	1	1	1	1	240639-1	STRIPPER (MACHINING)	27
	-	2	2	2	2	2	1320906-1	STUD, THREADED	25
	-	1	1	1	1	1	1752371-6	PLATE, STRIP GUIDE	24
	-	1	1	1	1	1	240825-1	PLATE, STRIP HOLD DOWN	23
	-	2	2	2	2	2	2-22281-3	SPRING, COMPRESSION	22
	-	1	1	1	1	1	1752373-4	DRAG	20
	-	2	2	2	2	2	1901259-3	GUIDE, LOWER STRIP	18
	-	4	4	4	4	4	1-2079383-1	SCR, BHSC, RoHS (M6 X 12)	17
	-	1	1	1	1	1	4-240641-2	SPACER	16
	-	1	1	1	1	1	1752360-1	SPACER, HOLD-DOWN	13
1	-	1	1	1	1	1	240833-2	PLATE, REAR SHEAR	11
	-	-	-	-	-	-	-	-	10
1	-	1	1	1	1	1	690496-6	PLATE, FRONT SHEAR	9
1	1	1	1	1	1	1	3-1803001-1	ANVIL, COMBINATION, END FEED	8
1	-	1	1	1	1	1	2217206-2	BLADE, SLUG	7
	-	-	-	-	-	-	-	-	6
	-	1	1	1	1	1	6-240641-5	SPACER	5
	-	1	1	1	1	1	238009-1	BLOCK, FL CRIMPER SPACER	4
1	1	1	1	1	1	1	2-1803016-5	CRIMPER, INSULATION F	3
	-	1	1	1	1	1	455888-3	SPACER, CRIMPER	2
1	1	1	1	1	1	1	1-456406-5	CRIMPER, WIRE PREMIUM	1
-77	-7	-6	-5	-2	-1		PART NO	DESCRIPTION	ITEM NO

DIMENSIONS:		TOLERANCES UNLESS OTHERWISE SPECIFIED:		DWG		REV	
mm	0 PLC	±	03OCT2013	BOB	HIGMAN	03OCT2013	
	1 PLC	±	03OCT2013	CH	ELBIN	03OCT2013	
	2 PLC	±		APVD	M. CLIFFORD	03OCT2013	
	3 PLC	±		NAME: Ocean End Feed Applicator			
	4 PLC	±		SIZE: CAGE CODE: DRAWING NO: RESTRICTED TO			
	ANGLES	±		A1 00779 ©=2150376			
MATERIAL:	FINISH:	WEIGHT:	SCALE:	Customer Accessible Production Drawing			
			1:1	SHEET 1 OF 4 REV B			

LOC		DIST		REVISIONS			
A	66	P	LTM	DESCRIPTION	DATE	OWN	APVD
				SEE SHEET 1			

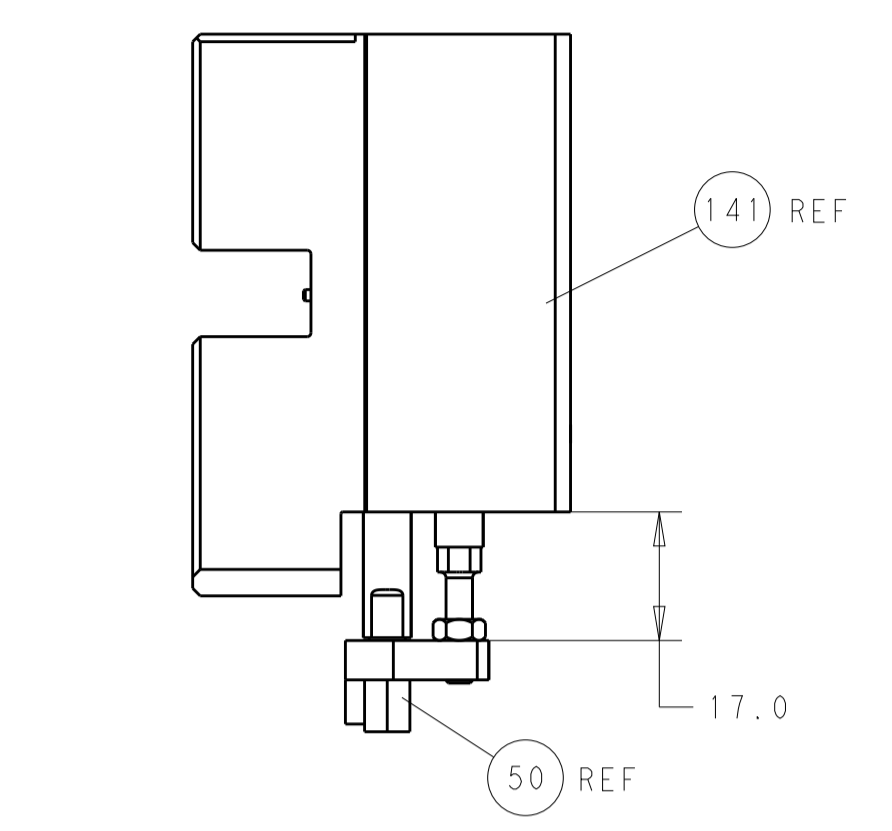

HOLDDOWN SET-UP

FEED TYPE
MECHANICAL

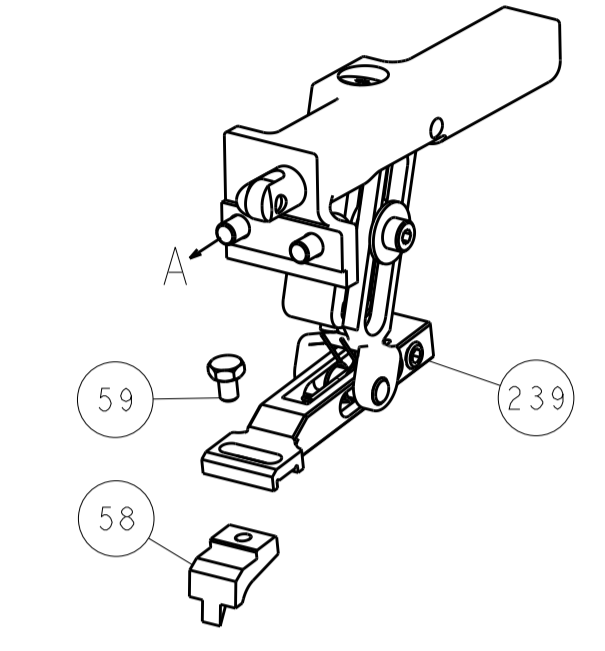

PNEUMATIC

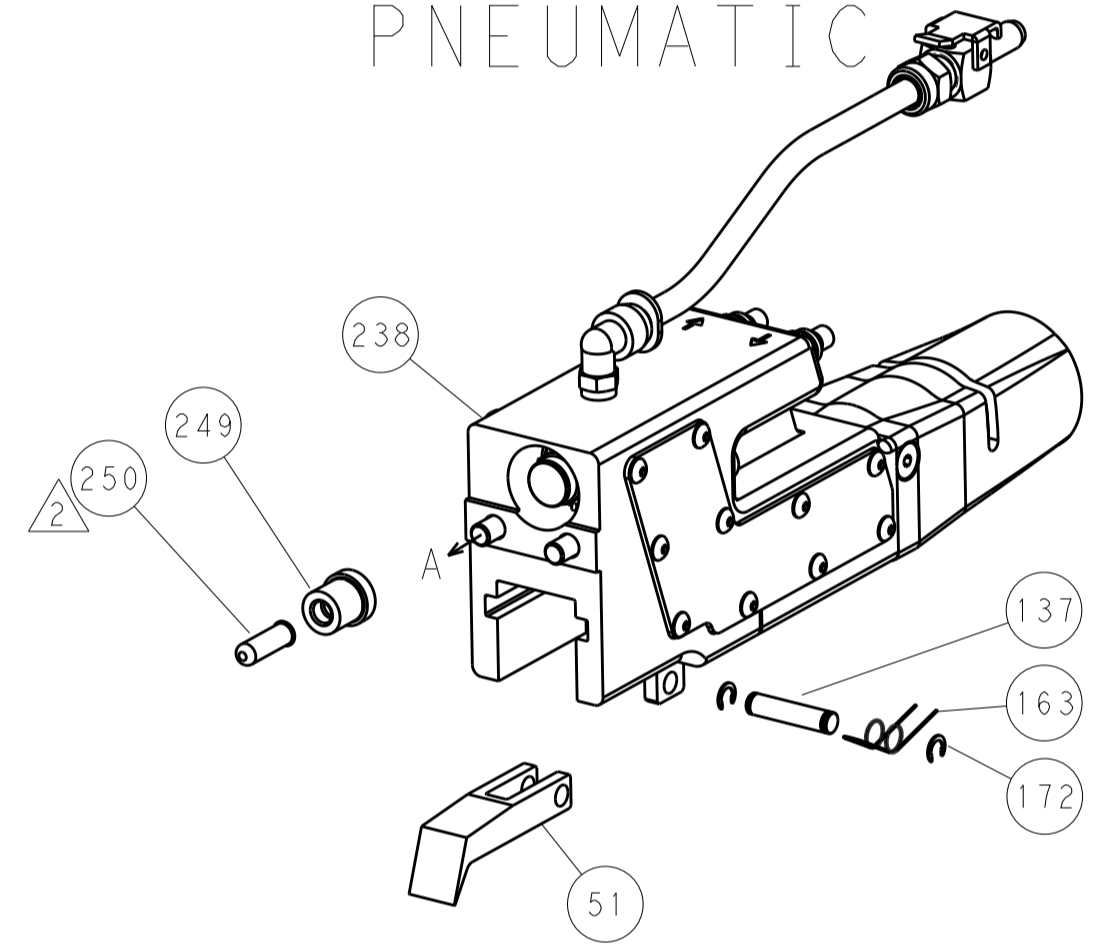

SERVO
LATCH PLATE

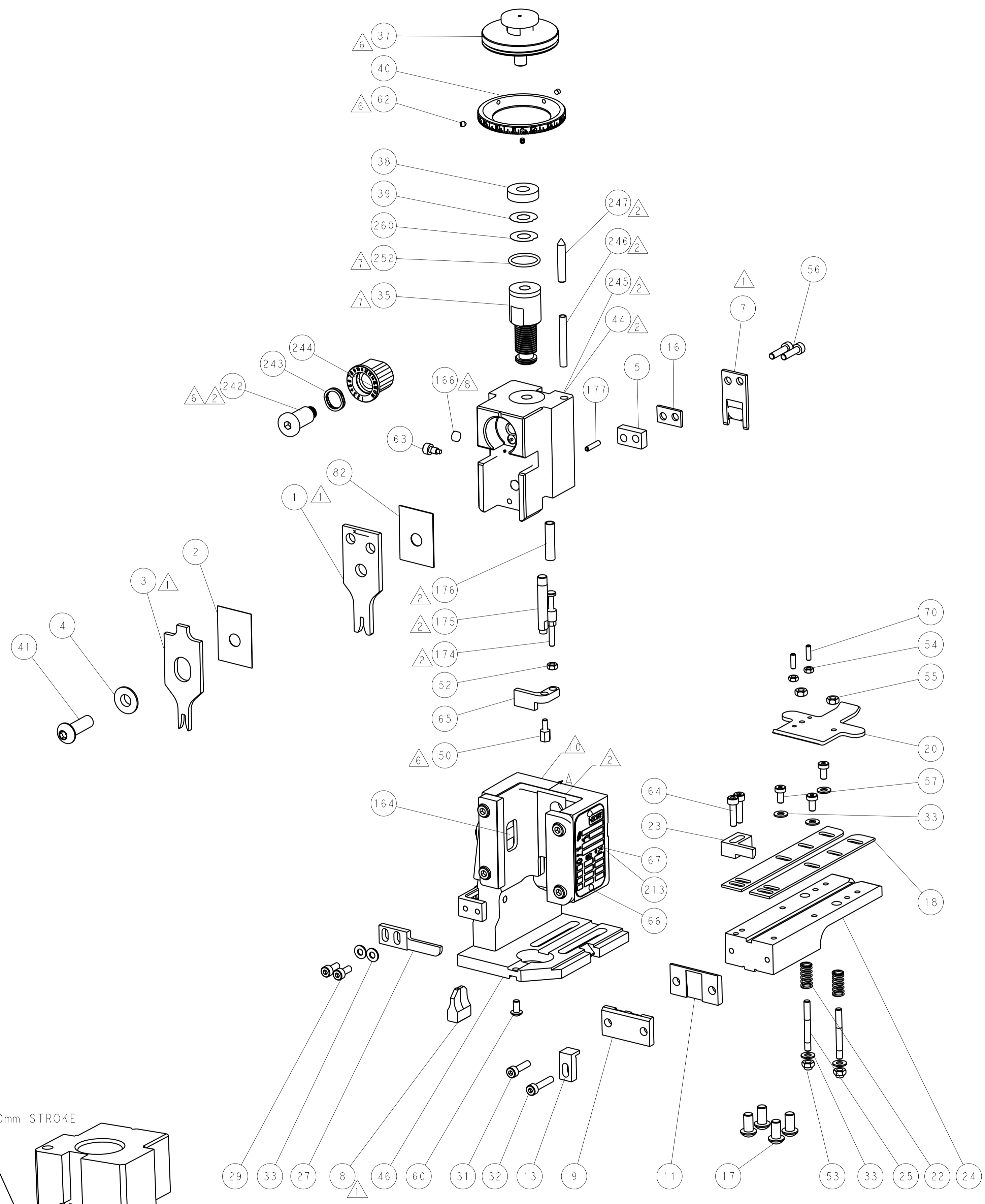
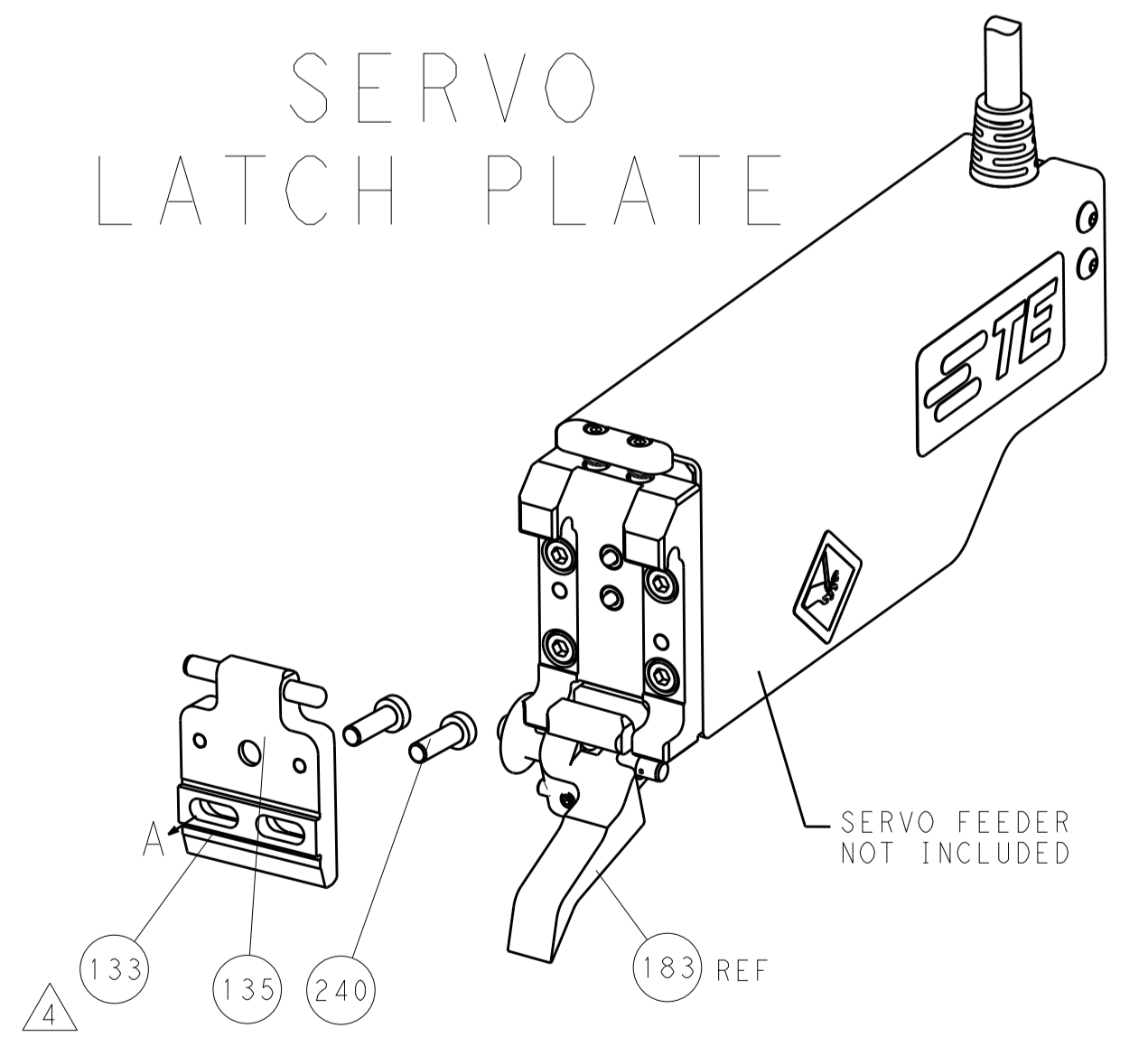

CAM POSITIONS



ATLANTIC VERSION
 Shown on sheets 1 of 4 & 2 of 4
 (Pacific version shown on sheets 3 of 4 & 4 of 4)

DIMENSIONS:		TOLERANCES UNLESS OTHERWISE SPECIFIED:		DWG: BOB_HIGMAN 03OCT2013		TE Connectivity	
mm	0 PLC	±		CHK: T_ELFIN 03OCT2013	NAME: Ocean End Feed Applicator		TE Connectivity Harrisburg, PA 17105-3608
	1 PLC	±		APVD: M_CLIFFORD 03OCT2013	RESTRICTED TO		
	2 PLC	±		PRODUCT SPEC	SIZE: A11		
	3 PLC	±		APPLICATION SPEC	CAGE CODE: 00779		
	4 PLC	±		WEIGHT	DRAWING NO: 2150376		
MATERIAL:	FINISH:			Customer Accessible Production Drawing	SCALE: 1:1	SHEET: 2 OF 4	REV: B

PACIFIC VERSION TERMINATOR INTERFACE ADAPTER	PART NUMBER	REVISION	DESCRIPTION	FEED TYPE	APPLICATOR STYLE CONVERSION CHART						
					CONVERT TO	PART NUMBERS REQUIRED					
						PNEUMATIC FEED	2119950-1	2119792-2	-	2119641-2	-
	2-2150376-1	B	FINE CRIMP HEIGHT ADJUST	MECHANICAL	SERVO LATCH PLATE	2119951-1	1901697-1	8-2150376-5	-	-	2168400-7 (QUANTITY 2)
					SMART APPLICATOR	2161326-1	-	8-2150376-4	-	-	-
	2-2150376-2	B	FINE CRIMP HEIGHT ADJUST	PNEUMATIC	MECHANICAL FEED	2119949-1	2063961-1	5-18022-5	2119653-2	-	-
					SERVO LATCH PLATE	2119951-1	1901697-1	8-2150376-5	-	-	2168400-7 (QUANTITY 2)
					SMART APPLICATOR	2161326-1	-	8-2150376-4	-	-	-
	2-2150376-5	B	FINE CRIMP HEIGHT ADJUST	SERVO LATCH PLATE ⁴	MECHANICAL FEED	2119949-1	2063961-1	5-18022-5	2119653-2	-	-
					PNEUMATIC FEED	2119950-1	2119792-2	-	2119641-2	-	2063440-1
	2-2150376-7	B	FINE CRIMP HEIGHT ADJUST	NONE	-	-	-	-	-	-	-
	7-2150376-7	B	CRIMP TOOLING KIT	-	-	-	-	-	-	-	-

APPLICATOR DATA		
CRIMP	SIZE	TYPE
WIRE	2.28 mm [.090]	F
INSUL	3.00 mm [.118]	F
APPL INSTRUCTIONS 408-10390		

TERMINAL DATA: TE TERMINAL		TE CRIMP SPECIFICATION	
TERMINAL NAME: L.1.F. POSITIVE LOCK CONTACT 5MM SERIES			
WIRE STRIP LENGTH		INSULATION DIAMETER RANGE	
3.50-4.50 mm [.138-.177 IN]		1.30-2.00 mm [.051-.079 IN]	
TERMINAL APPLICATION SPECIFICATION	114-15008	-	-
TERMINALS APPLIED			
TE TERMINAL	TE TERMINAL	TE TERMINAL	TE TERMINAL
141991-1	141991-3	1-141991-2	142685-3
141991-2	1-141991-1	2-141991-2	

WIRE SIZE	CRIMP HEIGHT mm [INCH]	CRIMP HEIGHT REFERENCE SETTING ⁹
0.6+0.35	1.42 +/- 0.05 [.056 +/- .002]	8.5
1.00mm2	1.42 +/- 0.05 [.056 +/- .002]	8.5
0.35+0.35	1.35 +/- 0.05 [.053 +/- .002]	9.4
0.60mm2	1.29 +/- 0.05 [.051 +/- .002]	10.1
0.35mm2	1.19 +/- 0.05 [.047 +/- .002]	11.4

- RECOMMENDED SPARE PARTS
- GREASE BEARING SURFACES LIGHTLY
- 3. LUBRICATE DAILY PER THE APPLICATOR INSTRUCTION SHEET SUPPLIED WITH THE APPLICATOR.
- APPLICATOR SPECIFIC DATA TO BE ENTERED INTO BLANK MEMORY CHIP AT ASSEMBLY. SEE BELOW FOR PART NUMBER:
 MECHANICAL FEED WITH "SMART APPLICATOR" CONVERSION: 8-2150376-4
 PNEUMATIC FEED WITH "SMART APPLICATOR" CONVERSION: 8-2150376-4
 SERVO FEED WITH "FINE CRIMP HEIGHT ADJUST": 8-2150376-5
- 5. ADJUSTMENT OF THE STRIPPER MAY BE REQUIRED WHEN MOVING THE APPLICATOR BETWEEN BENCH AND LEADMAKER APPLICATIONS.
- APPLY PART NUMBER 1-23419-5 LOCTITE TO THREADS OF ITEMS 50 & 62. APPLY PART NUMBER 2-23419-6 LOCTITE TO THREADS OF ITEM 242.
- GREASE THREADS, GROOVE AND O-RING ON ITEMS 139 & 153.
- MAGNET, ITEM 166 MUST BE ORIENTED CORRECTLY IN ORDER TO PROPERLY ACTUATE THE COUNTER.
- CRIMP HEIGHT REFERENCE SETTING WAS THE SETTING USED WHEN THE APPLICATOR WAS QUALIFIED AT THE FACTORY. ADJUSTMENT MAY BE NECESSARY WHEN RUNNING APPLICATOR IN THE FIELD.
- SPARE FEED CAM STORAGE LOCATION REFER TO INSTRUCTION SHEET FOR ADDITIONAL INFORMATION.
- THE RECOMMENDED SET-UP FOR END FEED APPLICATORS IS POST-FEED WITH ITEM 2119653-1. THE APPLICATOR CAN BE CONFIGURED FOR PRE-FEED WITH ITEM 2119652-1 BUT MAY ENCOUNTER PROBLEMS WITH SOME APPLICATIONS. FEED ISSUES OR TERMINAL JAMMING MAY OCCUR IN THE PRE-FEED CONFIGURATION.

***WARNING**
 ON INSTALLATION, SET WIRE DISC, ITEM 40 TO LARGEST WIRE SIZE SETTING. USE OF SETTINGS BELOW MINIMUM REQUIRED CRIMP HEIGHT SETTING WILL CAUSE DAMAGE TO CRIMP TOOLING.

-	1	1	1	1	2119782-1	FINE ADJUST HEAD ASM, PACIFIC STYLE	251
-	-	-	-	-	2119640-1	PUSH ROD, AIR FEED	250
-	-	-	-	-	2079988-1	BUSHING, LCH5-12, MISUMI	249
-	1	1	1	1	1-22279-3	SPRING, COMPRESSION	246
-	1	1	1	1	2119082-9	CAM, SNAIL, INSULATION ADJUSTMENT	244
-	1	1	1	1	2079764-1	WASHER, WAVE SPRING, CREST-TO-CREST	243
-	1	1	1	1	2119083-1	RETAINER, INSULATION DIAL	242
-	-	-	-	-	2168400-7	SHCS, LOW HEAD, RoHS, M5 X 10	240
-77-27-25-22-21	PART NO		DESCRIPTION		ITEM NO		

PACIFIC VERSION
 Shown on sheets 3 of 4 & 4 of 4
 (Atlantic version shown on sheets 1 of 4 & 2 of 4)

SET UP GAUGE	LOC	DIST	REVISIONS			
2119599-2	A	66	REV	DATE	BY	APPV
			-	SEE SHEET 1	-	-

-	-	-	-	1	2119580-1	MECHANICAL FEED ASSEMBLY	239
-	-	-	-	1	2063440-1	AIR FEED MODULE	238
-	-	-	-	1	2119740-2	TAG, IDENTIFICATION	213
-	4	4	4	4	2079383-9	SCR, BHSC, RoHS (M6 X 20)	186
-	-	REF	-	-	1901697-1	FEED FINGER ASSEMBLY, EF	183
-	1	1	1	1	6-993111-6	PIN, SLOTTED SPRING 3.0 X 14.0	177
-	1	1	1	1	8-22280-7	SPRING, COMPRESSION	176
-	1	1	1	1	1752353-2	GUIDE PIN, HOLDDOWN	175
-	1	1	1	1	1901680-2	GUIDE PIN, HOLDDOWN	174
-	-	-	-	2	21045-3	RING, RETAIN, EXTERN, 3/16 CRESCENT	172
-	1	1	1	1	994969-1	MAGNET, RARE EARTH HIGH ENERGY	166
-	REF	REF	REF	REF	994970-2	COUNTER, MAGNETIC	164
-	-	-	-	1	240638-1	SPRING, FEED FINGER	163
-	1	1	1	1	8-21084-1	O-RING, .801 ID, .070 DIA. MAT.	153
-	-	-	-	1	2119641-2	FEED CAM, AIR FEED	152
-	1	1	1	1	2119798-2	DETENT PIN	145
-	1	1	1	1	2079383-8	SCR, BHSC, RoHS (M4 X 16)	144
-	-	-	-	1	2119653-2	FEED CAM, POST FEED	142
-	1	1	1	1	2119655-6	APPLICATOR BASIC ASSEMBLY, EF	141
-	1	1	1	1	2119651-1	RAM, ASIAN STYLE, END FEED	140
-	1	1	1	1	2119092-2	BOLT, ADJUSTMENT	139
-	-	-	-	1	3-23627-7	PIN, RETAIN, GRVD, 3/16 X .854	137
-	-	REF	-	-	SEE NOTE 4	MEMORY CHIP, PROGRAMMED	135
-	-	1	-	-	1633743-1	SERVO FEED LATCH ASM	133
-	1	1	1	1	455888-5	SPACER, CRIMPER	82
-	1	1	1	1	2119956-2	DOCUMENTATION PACKAGE	71
-	2	2	2	2	2-18032-2	SCR, SET, FLT POINT M3 X 10.0	70
-	1	-	-	1	2119740-1	TAG, IDENTIFICATION	67
-	2	2	2	2	2168078-1	SCREW, DRIVE, RH, RoHS, 2 x .188	66
-	1	1	1	1	1901681-1	HOLDDOWN, TERMINAL	65
-	2	2	2	2	2168083-8	SCR, SKT HD CAP, RoHS, M4 X 16	64
-	1	1	1	1	2119793-1	LIMITER, ADJUSTMENT BOLT	63
-	3	3	3	3	992763-5	SCR, SET, SOC, CONE POINT, M3 X 4.0	62
-	-	-	-	1	5-18022-5	SCR, HEX HD CAP, M4 X 6.0	59
-	-	-	-	1	2063961-1	FEED FINGER	58
-	3	3	3	3	2168400-4	SHCS, LOW HEAD, RoHS, M4 X 8	57
-	2	2	2	2	2168083-8	SCR, SKT HD CAP, RoHS, M4 X 16	56
-	2	2	2	2	5018030-2	NUT, HEX, REG, RoHS, M4	55
-	2	2	2	2	5018030-1	NUT, HEX, REG, RoHS, M3	54
-	2	2	2	2	986965-8	NUT, LOCK, HEX, TORQUE (M4)	53
-	1	1	1	1	1-5018030-0	NUT, HEX, REG, RoHS, M3.5	52
-	-	-	-	1	2119792-2	PAWL, EF, AIR	51
-	1	1	1	1	1-1752354-2	STANDOFF, HOLD-DOWN	50
-	-	-	-	1	18023-9	SCR, SKT HD CAP M4 X 6.0	49
-	-	-	-	1	2119652-1	FEED CAM, PRE FEED	48
-	1	1	1	1	2079383-7	SCR, BHSC, RoHS (M8 X 25)	41
-	1	1	1	1	2119645-1	DISC, NUMBERED FA WIRE ADJUSTMENT	40
-	1	1	1	1	2119957-1	APPLICATOR SHIM PACK	39
-	1	1	1	1	1-2119644-2	RAM WASHER, PRECISION	38
-	7	7	7	7	1-18028-2	WASHER, FLAT, REG M4	33
-	1	1	1	1	2168083-9	SCR, SKT HD CAP, RoHS, M4 X 20	32
-	1	1	1	1	2168083-8	SCR, SKT HD CAP, RoHS, M4 X 16	31
-	2	2	2	2	1-2168083-0	SCR, SKT HD CAP, RoHS, M4 X 10	29
-	1	1	1	1	240639-1	STRIPPER (MACHINING)	27
-	2	2	2	2	1320906-1	STUD, THREADED	25
-	1	1	1	1	1752371-6	PLATE, STRIP GUIDE	24
-	1	1	1	1	240825-1	PLATE, STRIP HOLD DOWN	23
-	2	2	2	2	2-22281-3	SPRING, COMPRESSION	22
-	1	1	1	1	1752373-4	DRAG	20
-	2	2	2	2	1901259-3	GUIDE, LOWER STRIP	18
-	1	1	1	1	4-240641-2	SPACER	16
-	1	1	1	1	1752360-1	SPACER, HOLD-DOWN	13
-	1	1	1	1	240833-2	PLATE, REAR SHEAR	11
-	-	-	-	-	-	-	10
-	1	1	1	1	690496-6	PLATE, FRONT SHEAR	9
-	1	1	1	1	3-1803001-1	ANVIL, COMBINATION, END FEED	8
-	1	1	1	1	2217206-2	BLADE, SLUG	7
-	-	-	-	-	-	-	6
-	1	1	1	1	6-240641-5	SPACER	5
-	1	1	1	1	238009-1	BLOCK, FL CRIMPER SPACER	4
-	1	1	1	1	2-1803016-5	CRIMPER, INSULATION F	3
-	1	1	1	1	455888-3	SPACER, CRIMPER	2
-	1	1	1	1	1-456406-5	CRIMPER, WIRE PREMIUM	1
-77-27-25-22-21	PART NO		DESCRIPTION		ITEM NO		

DIMENSIONS:		TOLERANCES UNLESS OTHERWISE SPECIFIED:		DWG		REV	
mm	0 PLC ±	1 PLC ±	2 PLC ±	3 PLC ±	4 PLC ±	5 PLC ±	ANGLES ±
MATERIAL:	FINISH:	WEIGHT:	SCALE:	DATE:	BY:	APPV:	PRODUCT SPEC:
				03OCT2013	BOB HIGMAN	03OCT2013	TE Connectivity
				03OCT2013	T. ELBIN	03OCT2013	Harrisburg, PA 17105-3608
				03OCT2013	M. CLIFFORD	03OCT2013	Ocean End Feed Applicator
				03OCT2013		03OCT2013	Customer Accessible Production Drawing
				03OCT2013		03OCT2013	SCALE 1:1 SHEET 3 OF 4 REV B

LOC		DIST		REVISIONS			
A	66	P	LTM	DESCRIPTION	DATE	OWN	APVD
				SEE SHEET 1			

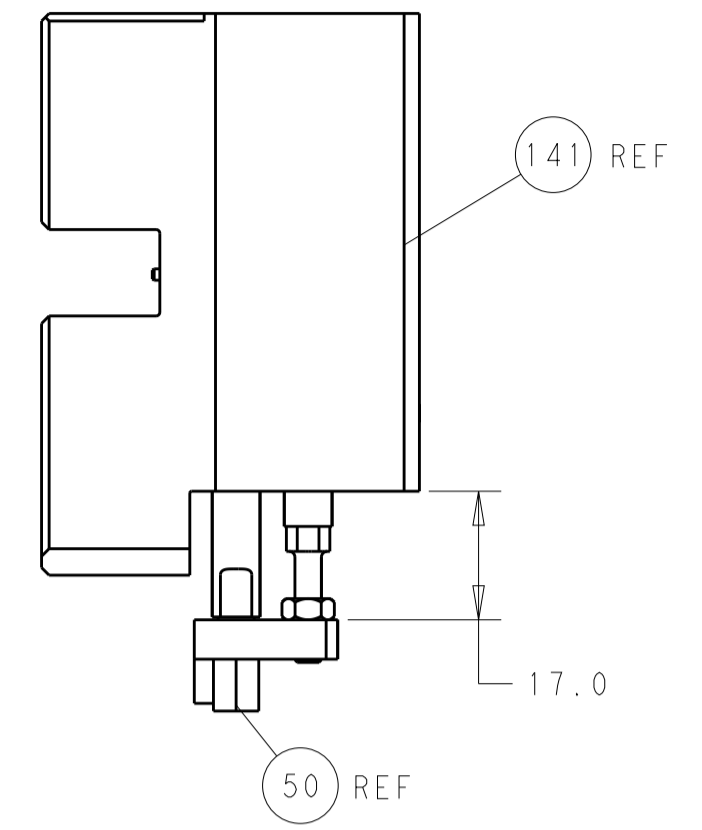

HOLDDOWN SET-UP

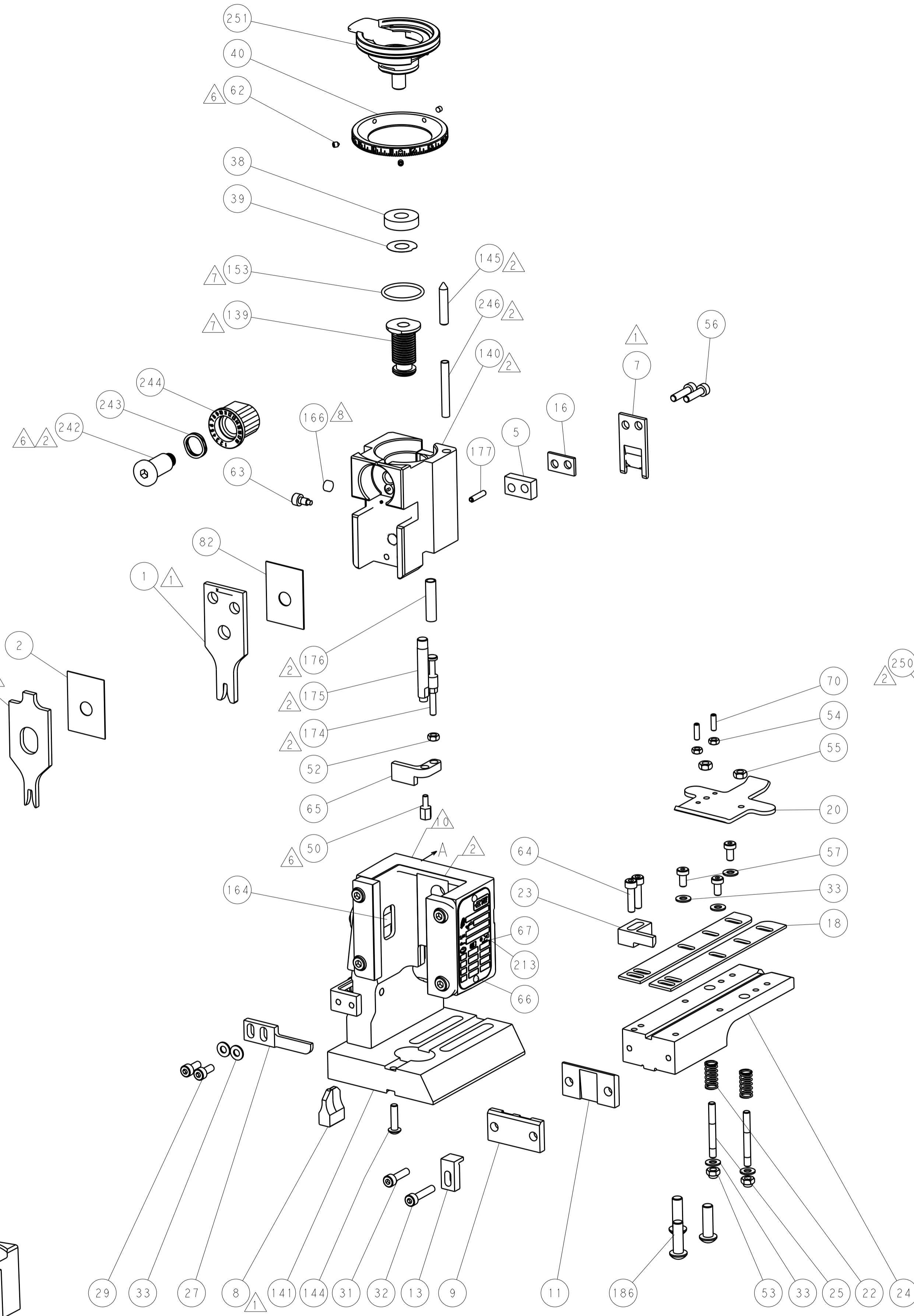

FEED TYPE
MECHANICAL

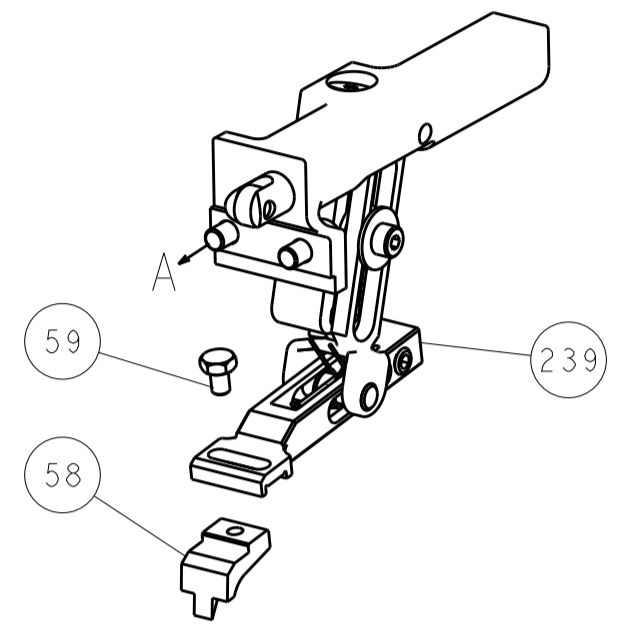

PNEUMATIC

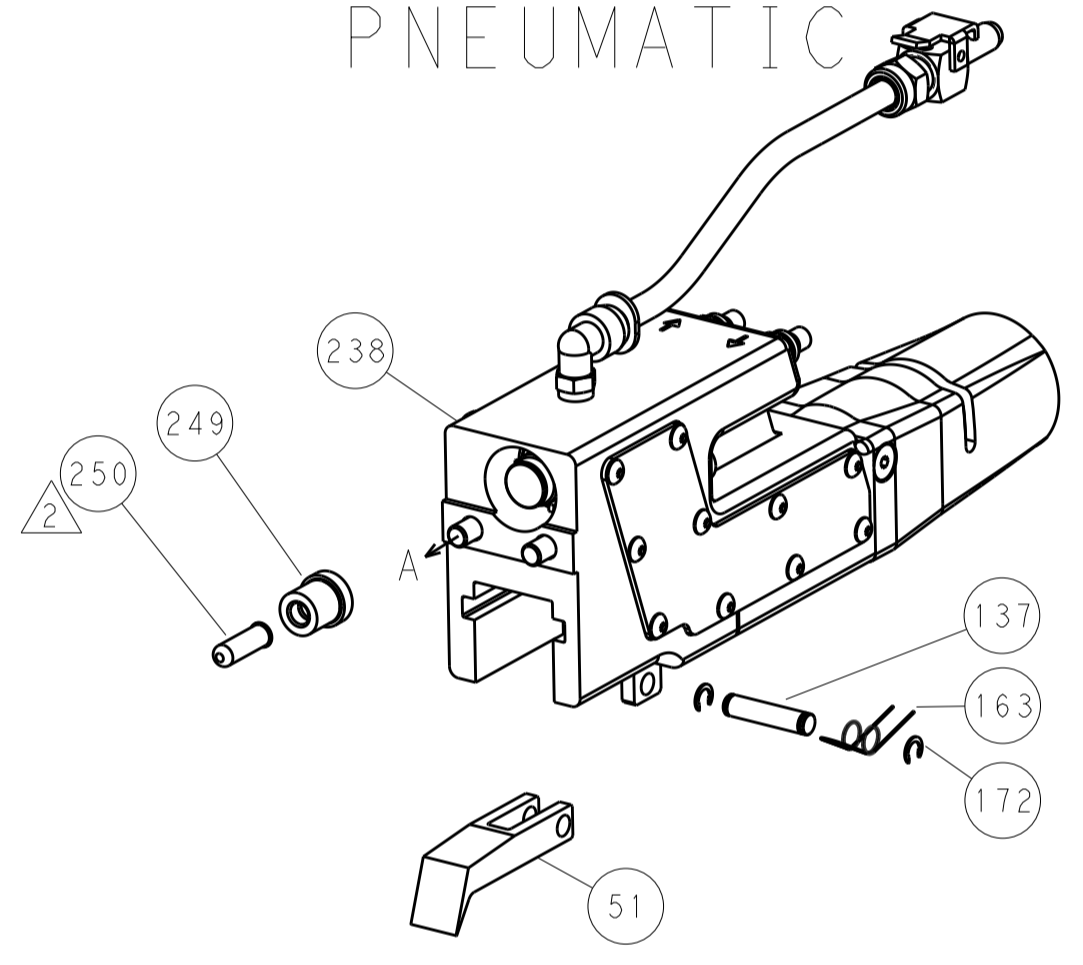

SERVO
LATCH PLATE

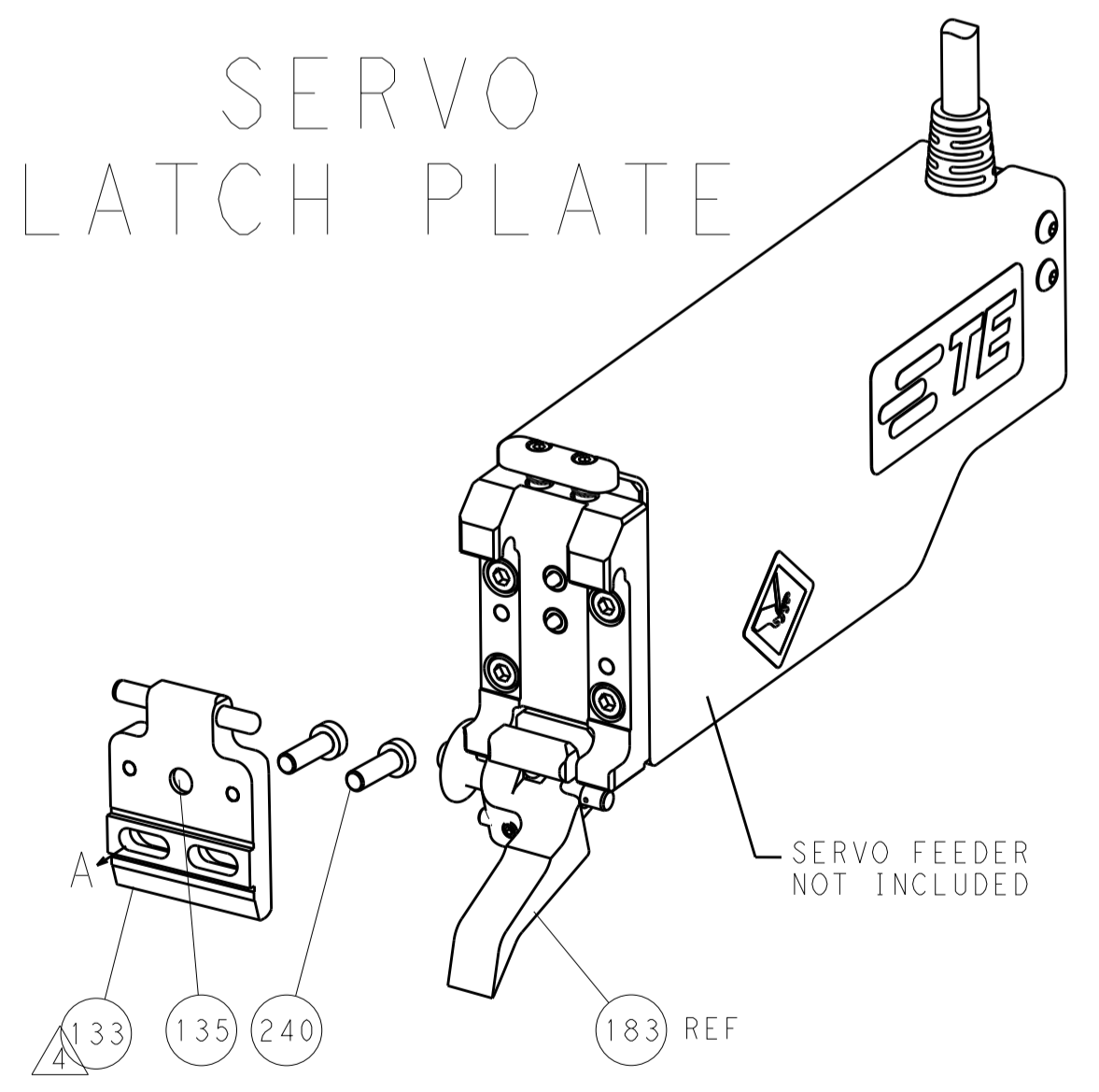

CAM POSITIONS

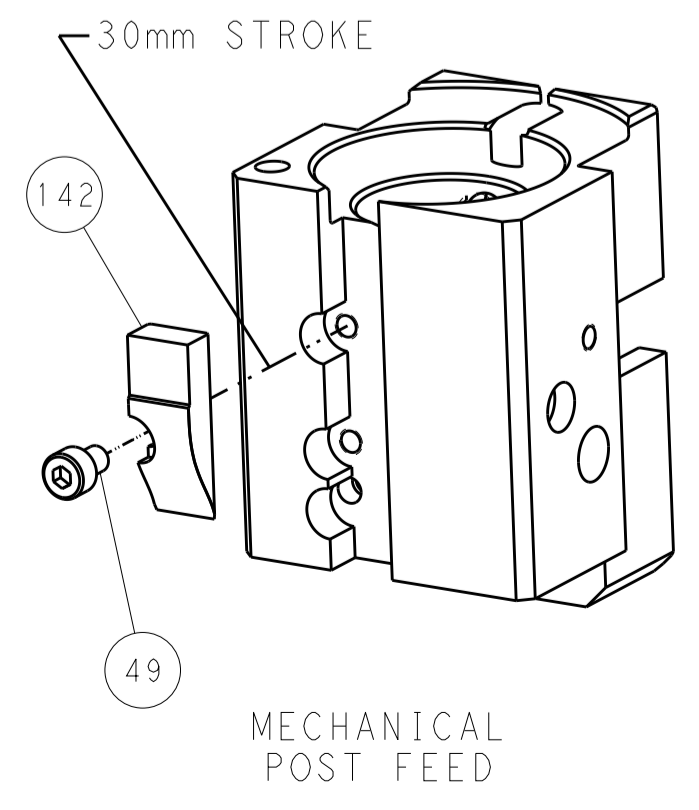

MECHANICAL
POST FEED

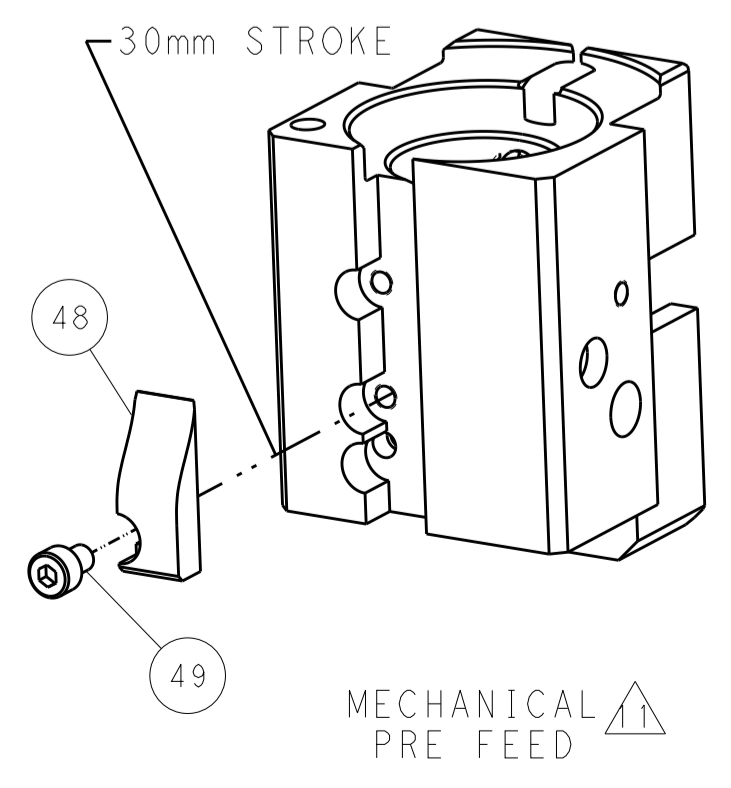

MECHANICAL
PRE FEED

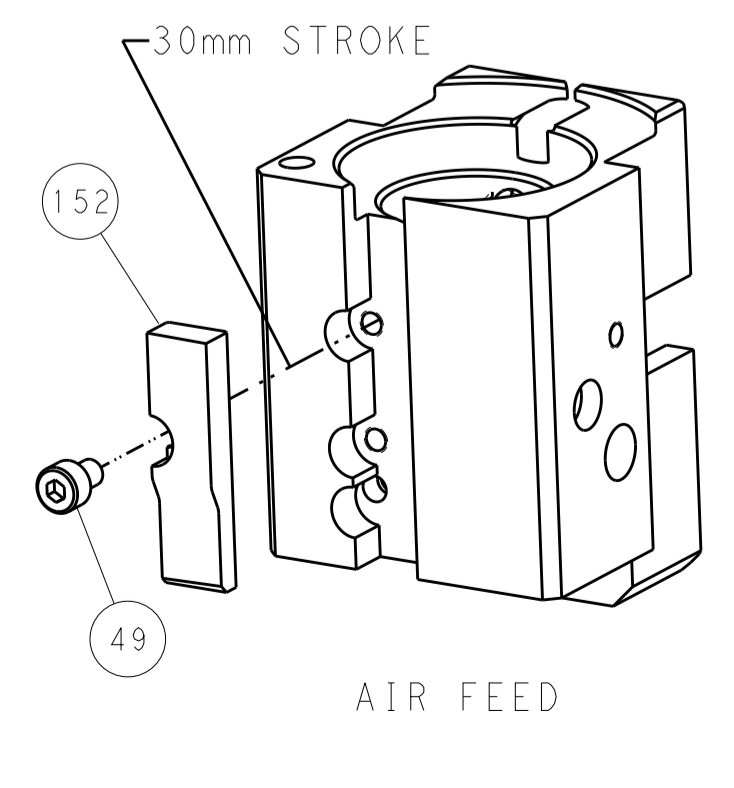

AIR FEED

PACIFIC VERSION
 Shown on sheets 3 of 4 & 4 of 4
 (Atlantic version shown on sheets 1 of 4 & 2 of 4)

DIMENSIONS:		TOLERANCES UNLESS OTHERWISE SPECIFIED:		DWG: BOB_HIGMAN 03OCT2013		TE Connectivity	
mm	0 PLC	±		CHK: T_ELFIN 03OCT2013	NAME		Harrisburg, PA 17105-3608
	1 PLC	±		APVD: M_CLEFFORD 03OCT2013	Ocean End Feed		
	2 PLC	±		PRODUCT SPEC	Applicator		
	3 PLC	±		APPLICATION SPEC	SIZE		RESTRICTED TO
	4 PLC	±		ANGLES	CAGE CODE		
	FINISH	±		WEIGHT	DRAWING NO		
MATERIAL					A1 00779		
					C=2150376		
					Customer Accessible Production Drawing		
					SCALE	SHEET	REV
					1:1	4 OF 4	B