

MAPX	MODIFICATION	DATE

Specification:
 1. Electrical Characteristics:
 Dielectric Withstanding Voltage: AC 500V/1MINUTE.
 Insulation Resistance: 1000 MΩ/Min.
 Contact Resistance: 30 mΩ Max.
 2. Mechanical Characteristics:
 INSERTION FORCE: 30N (3.06Kgf) MAX
 EXTRACTION FORCE: 10~30N (1.02~3.06Kgf)
 Durability: 1500cycles. EXTRACTION FORCE: 10~30N (1.02~3.06Kgf)
 3. Material:
 Terminal: Phosphor Bronze, C2680R-EH T=0.25
 Plating: Gold 0.76 um Min plating over 1.27 um Min
 Nickel underplate, 2.54 um Min Sn selective plating on solder tail:
 Shell: Bronze, SPCCR-H =0.30mm
 Plating: Nickel underplate 2.54 um Min;
 Housing: PBT white
 4. Environmental:
 Operating Temperature: 0° C to +85° C.

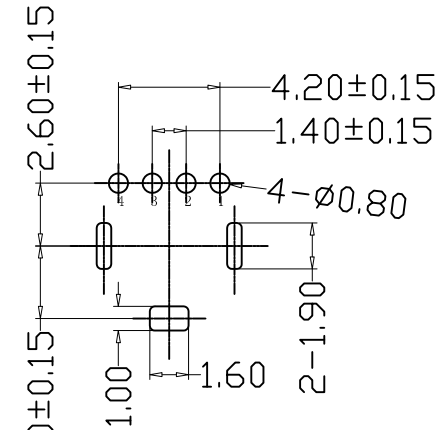
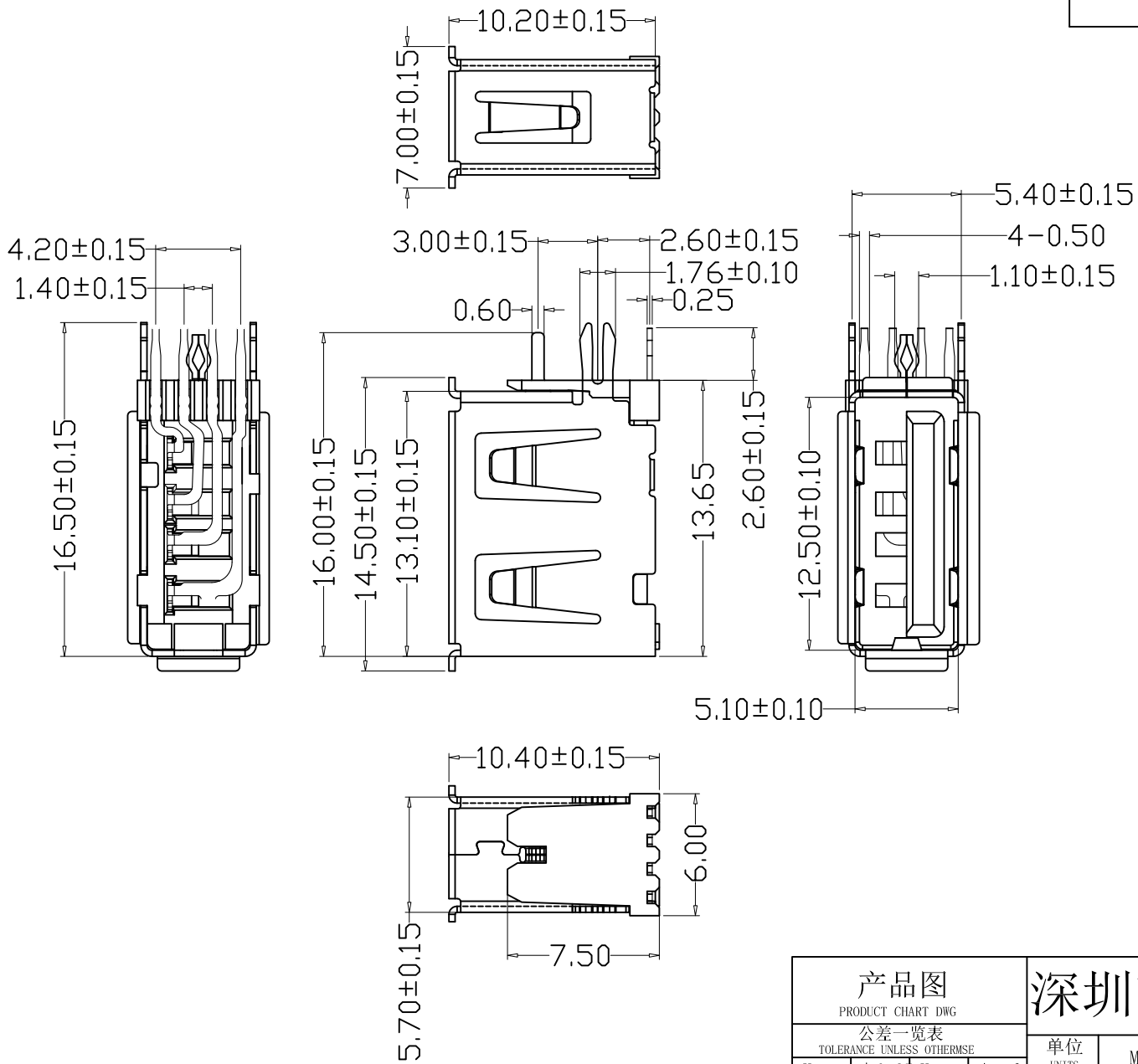

产品图 PRODUCT CHART DWG		深圳市精拓金电子有限公司							
公差一览表 TOLERANCE UNLESS OTHERWISE		单位 UNITS	MM	制图 DRAWING	邱建辉	制图料号 PRODUCT PART NO.	906-852A1014D10200		
X.	±0.25	X.	±5.°	比例 SCALE	1:1	审核 CHKD	郭治富	产品名称 PRODUCT NO.	AF10.0侧插短体外鱼叉内0型脚有边 铜壳PBT白胶
.X	±0.20	.X	±2.°	日期 DATE	2014.02.20	核准 APPD	黄国荣	角法 VIEW	⊕ ⊖
.XX	±0.15	.XX	±1.°					版本 VER	AO
.XXX	±0.10	.XXX	±0.5°						