

PLEASE CHECK WWW.MOLEX.COM FOR LATEST PART INFORMATION

Part Number: [0749802514](#)
Status: **Active**
Overview: [vhdm_hsd](#)
Description: 2.00mm (.079") Pitch 6-Row VHDM-HSD™ Backplane Header, Guide Pin Signal Module, Pin End Version, 100 Circuits, Pin Length 5.15mm (.203")

Documents:

[Drawing \(PDF\)](#) [RoHS Certificate of Compliance \(PDF\)](#)

Agency Certification

CSA LR19980

General

Product Family	Backplane Connectors
Series	74980
Application	Backplane
Application Tooling Documents	Tooling Manual
Comments	Keying Position A
Component Type	PCB Header
Overview	vhdm_hsd
Product Name	VHDM-HSD™
Style	N/A

Physical

Circuits (Loaded)	100
Circuits (maximum)	100
Color - Resin	Black
Durability (mating cycles max)	200
First Mate / Last Break	No
Flammability	94V-0
Guide to Mating Part	Yes
Keying to Mating Part	Yes
Material - Metal	Copper-Nickel-Silicon, High Performance Alloy (HPA), Stainless Steel
Material - Plating Mating	Gold
Material - Plating Termination	Tin-Lead
Material - Resin	High Temperature Thermoplastic
Number of Columns	25
Number of Pairs	Open Pin Field
Number of Rows	6
Orientation	Vertical
PCB Retention	None
PCB Thickness Recommended (in)	0.070 In
PCB Thickness Recommended (mm)	1.80 mm
Packaging Type	Tube
Pitch - Mating Interface (in)	0.079 In
Pitch - Mating Interface (mm)	2.00 mm
Plating min: Mating (µin)	30
Plating min: Mating (µm)	0.75
Plating min: Termination (µin)	30
Plating min: Termination (µm)	0.75
Polarized to PCB	Yes
Stackable	Yes
Surface Mount Compatible (SMC)	Yes
Temperature Range - Operating	-55°C to +105°C

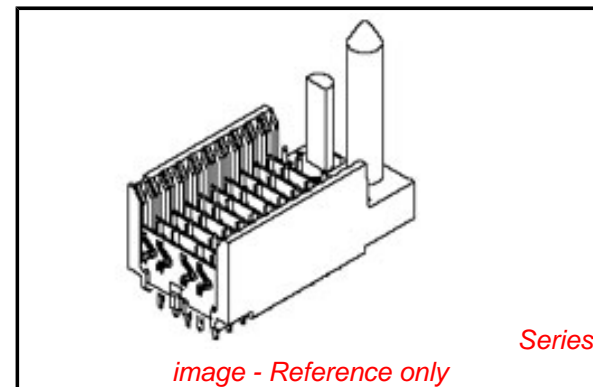

image - Reference only

EU RoHS

ELV and RoHS Compliant
REACH SVHC Not Reviewed
Halogen-Free Status Not Reviewed

China RoHS



Need more information on product environmental compliance?

Email productcompliance@molex.com
 For a multiple part number RoHS Certificate of Compliance, [click here](#)

Please visit the [Contact Us](#) section for any non-product compliance questions.

Search Parts in this Series

[74980Series](#)

Mates With

[74880 VHDMHSD Daughtercard](#)

Use With

[Daughtercard Modules](#)

Application Tooling | FAQ

Tooling specifications and manuals are found by selecting the products below. Crimp Height Specifications are then contained in the Application Tooling Specification document.

Global

Description	Product #
VHDM® Signal Pin Inserter Repair Tool	0622015700
VHDM-HSD™ Signal Header, 6 Row by 25 Wide, 50.00mm (1.97")	0622020217

Termination Interface: Style

Through Hole - Compliant Pin

Electrical

Current - Maximum per Contact

1A

Data Rate

5.0 Gbps

Real Signals (per 25mm)

48

Voltage - Maximum

120V AC (RMS)/DC

Material Info

Reference - Drawing Numbers

Sales Drawing

SD-74980-010

VHDM-HSD is a trademark of Amphenol Corporation

This document was generated on 05/28/2010

PLEASE CHECK WWW.MOLEX.COM FOR LATEST PART INFORMATION

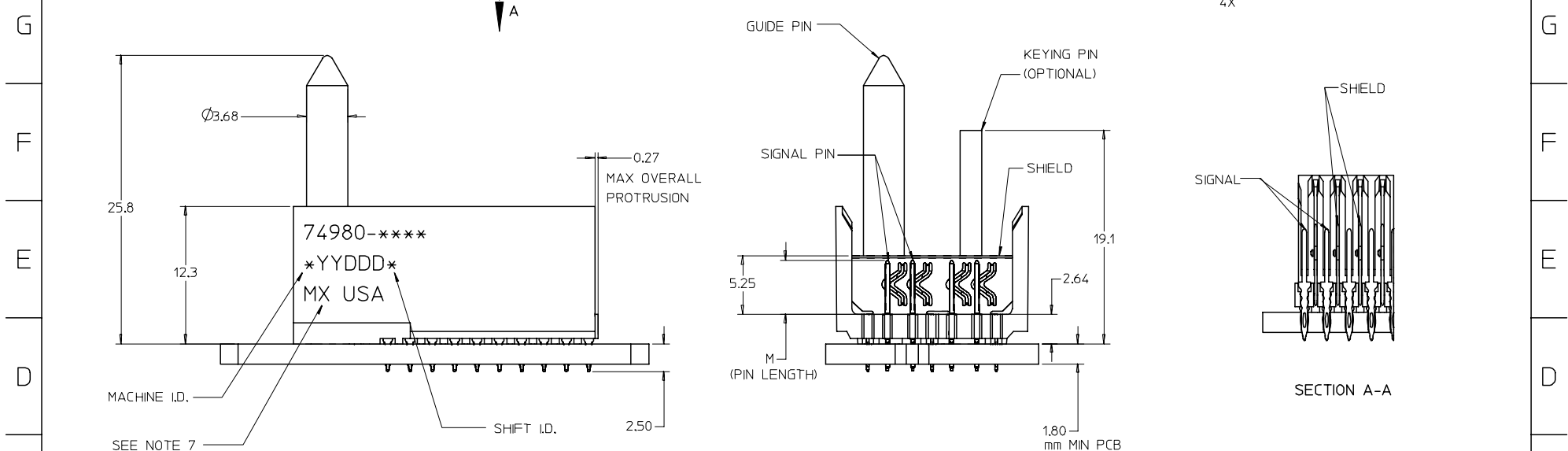
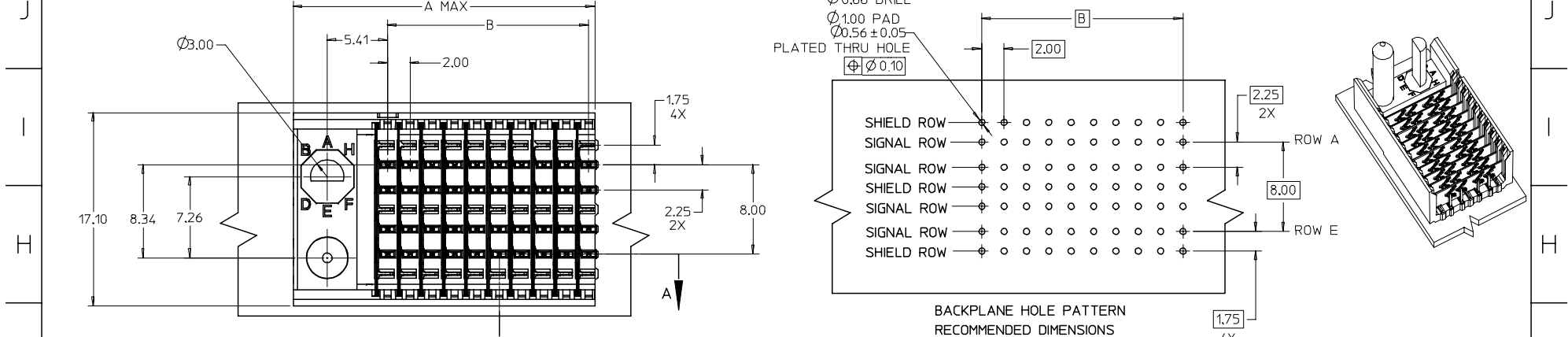

NOTES:
 1. MATERIAL: HOUSING-LIQUID CRYSTAL POLYMER (LCP) GLASS-FILLED. UL 94V-0. COLOR-BLACK. SIGNAL AND SHIELD - HIGH PERFORMANCE COPPER ALLOY.
 2. FINISHES:
 CONTACT AREA: SELECTIVE GOLD (Au)
 PCB TAILS: SELECTIVE TIN/LEAD (Sn/Pb) OR SELECTIVE MATTE TIN (Sn) NICKEL (Ni) OVERALL.
 3. THIS PART CONFORMS TO MOLEX PRODUCT SPECIFICATION PS-74031-999.
 4. FOR MIXED CONTACT MATING LENGTHS - CONSULT MOLEX FOR AVAILABILITY.
 5. FOR SPECIFIC PART NUMBER AND MATING INFORMATION REFER TO SHEET 2.
 6. PACKAGE PER PK-74058-003.
 7. EITHER MARK PART NUMBER AND DATE CODE APPROXIMATELY WHERE SHOWN OR PLACE LABEL ON TUBE.

ADD LEADFREE PINS EC NO: UCP2006-0067 DRAWN: KMULVEY 2005/07/15 CHKD: 2005/07/18 APPR: SREED 2005/08/11	DESCRIPTION REV	QUALITY SYMBOLS ▽=0 ◇=0	GENERAL TOLERANCES (UNLESS SPECIFIED)		SCALE 4:1	DESIGN UNITS METRIC	THIRD ANGLE PROJECTION	REVISE ON CAD ONLY	
			m	INCH	DIMENSION STYLE MM ONLY		TITLE HSD SALES ASSEMBLY 6 ROW SIGNAL END BACKPLANE		
			4 PLACES ± --- ± ---	3 PLACES ± --- ± ---	DRAWN BY NMARTIN	DATE 2002/09/04	MOLEX INCORPORATED		
			2 PLACES ± --- ± ---	1 PLACE ± --- ± ---	CHECKED BY SREED	DATE 2002/09/04	MATERIAL NO. SEE SHT 2	DOCUMENT NO. SD-74980-010	SHEET NO. 1 OF 2
		ANGULAR ± 1 °		APPROVED BY CBIXLER		DATE 2002/09/04	THIS DRAWING CONTAINS INFORMATION THAT IS PROPRIETARY TO MOLEX INCORPORATED AND SHOULD NOT BE USED WITHOUT WRITTEN PERMISSION		

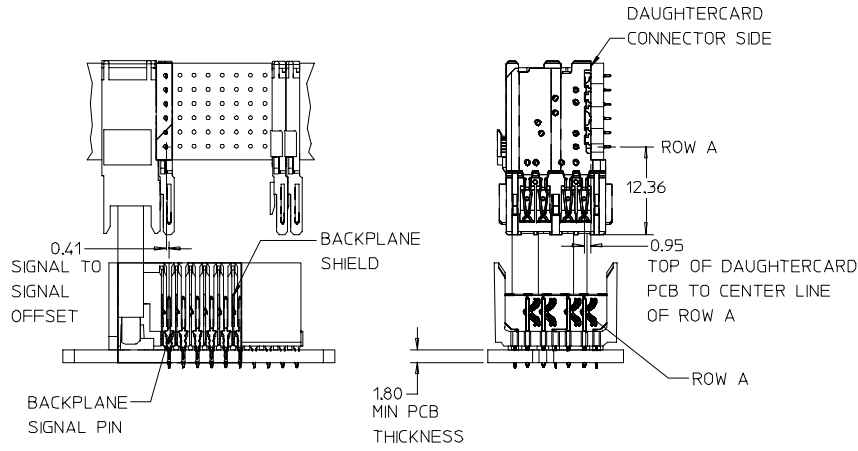

74980-****
 NUMBER OF COLUMNS/PLATING
 10 = 10 COLUMN TIN/LEAD
 25 = 25 COLUMN TIN/LEAD
 90 = 10 COLUMN MATTE TIN
 85 = 25 COLUMN MATTE TIN

SIGNAL PIN LENGTH (mm)
 1 & 6 = 4.75
 2 & 7 = 6.25
 3 & 8 = 4.25
 4 & 9 = 5.15

P/N 74980-()	-**0*	-**1*	-**2*	-**3*	-**4*	-**5*	-**6*	-**7*	-**8*
	0	A	B	C	D	E	F	G	H
KEYING PIN ORIENTATION									

PART NUMBER	COLUMN	NUMBER OF SIGNAL PINS	NUMBER OF SHIELDS	A MAX	B	M	Au (µm) MIN THICKNESS	Sn/Pb (µm) THICKNESS
74980-*0*1	10	40	10	27.00	18.00	4.75	0.76	0.38-152
74980-*0*6							1.27	
74980-*5*1	25	100	25	57.00	48.00		0.76	
74980-*5*6							1.27	
74980-*0*2	10	40	10	27.00	18.00	6.25	0.76	
74980-*0*7							1.27	
74980-*5*2	25	100	25	57.00	48.00		0.76	
74980-*5*7							1.27	
74980-*0*3	10	40	10	27.00	18.00	4.25	0.76	
74980-*0*8							1.27	
74980-*5*3	25	100	25	57.00	48.00		0.76	
74980-*5*8							1.27	
74980-*0*4	10	40	10	27.00	18.00	5.15	0.76	
74980-*0*9							1.27	
74980-*5*4	25	100	25	57.00	48.00		0.76	
74980-*5*9							1.27	

SEE SHT 1 EC NO: UCP2006-0067 DRAWN: KMULVEY 2005/07/15 CHKD: 2005/07/18 APPR: SREED 2005/08/11	QUALITY SYMBOLS	GENERAL TOLERANCES (UNLESS SPECIFIED)	SCALE 4:1	DESIGN UNITS METRIC	THIRD ANGLE PROJECTION	REVISE ON CAD ONLY															
	▽=0 ◻=0	<table border="1"> <tr> <th></th> <th>mm</th> <th>INCH</th> </tr> <tr> <td>4 PLACES</td> <td>± ---</td> <td>± ---</td> </tr> <tr> <td>3 PLACES</td> <td>± ---</td> <td>± ---</td> </tr> <tr> <td>2 PLACES</td> <td>± ---</td> <td>± ---</td> </tr> <tr> <td>1 PLACE</td> <td>± ---</td> <td>± ---</td> </tr> </table>		mm	INCH	4 PLACES	± ---	± ---	3 PLACES	± ---	± ---	2 PLACES	± ---	± ---	1 PLACE	± ---	± ---	DIMENSION STYLE MM ONLY	TITLE	HSD SALES ASSEMBLY 6 ROW SIGNAL END BACKPLANE	
		mm	INCH																		
	4 PLACES	± ---	± ---																		
3 PLACES	± ---	± ---																			
2 PLACES	± ---	± ---																			
1 PLACE	± ---	± ---																			
ANGULAR ± 1 ° DRAFT WHERE APPLICABLE MUST REMAIN WITHIN DIMENSIONS	DRAWN BY DATE NMARTIN 2002/09/04 CHECKED BY DATE SREED 2002/09/04 APPROVED BY DATE CBIXLER 2002/09/04	MATERIAL NO. SEE TABLE	DOCUMENT NO. SD-74980-010	SHEET NO. 2 OF 2																	
THIS DRAWING CONTAINS INFORMATION THAT IS PROPRIETARY TO MOLEX INCORPORATED AND SHOULD NOT BE USED WITHOUT WRITTEN PERMISSION																					