

PLEASE CHECK WWW.MOLEX.COM FOR LATEST PART INFORMATION

Part Number: [0520301929](#)
Status: **Active**
Overview:
Description: 1.00mm (.039") Pitch FFC/FPC Connector, Through-Hole, Vertical, ZIF Receptacle, 19 Circuits, Lead-free

General

Product Family	FFC/FPC Connectors
Series	52030
Overview	ffc_fpc_throughhole
Product Name	N/A

Physical

Circuits (Loaded)	19
Contact Position	N/A
Durability (mating cycles max)	30
Entry Angle	Vertical
Mated Height (in)	0.205 In
Mated Height (mm)	5.20 mm
Material - Metal	Phosphor Bronze
Material - Plating Mating	Tin-Bismuth
Material - Plating Termination	Tin-Bismuth
Material - Resin	Nylon, Polyester
Number of Rows	1
Orientation	Vertical
PC Tail Length (in)	0.126 In
PC Tail Length (mm)	3.20 mm
PCB Retention	Yes
PCB Thickness Recommended (in)	0.063 In
PCB Thickness Recommended (mm)	1.60 mm
Packaging Type	Tray
Pitch - Mating Interface (in)	0.039 In
Pitch - Mating Interface (mm)	1.00 mm
Polarized to PCB	No
Stackable	No
Temperature Range - Operating	-20°C to +80°C
Termination Interface: Style	Through Hole
Wire/Cable Type	FFC/FPC

Electrical

Current - Maximum per Contact	1A
Voltage - Maximum	50V

Material Info

Reference - Drawing Numbers

Product Specification	PS-52030-004, RPS-52030-005, RPS-52030-006, RPS-52030-018, RPS-52030-019, RPS-52030-023
Sales Drawing	SD-52030-017

EU RoHS
ELV and RoHS
Compliant
REACH SVHC
 Not Reviewed
Halogen-Free
Status
Not Reviewed

China RoHS



Need more information on product environmental compliance?

Email productcompliance@molex.com
 For a multiple part number RoHS Certificate of Compliance, [click here](#)

Please visit the [Contact Us](#) section for any non-product compliance questions.

Search Parts in this Series
[52030Series](#)

10 9 8 7 6 5 4 3 2 1

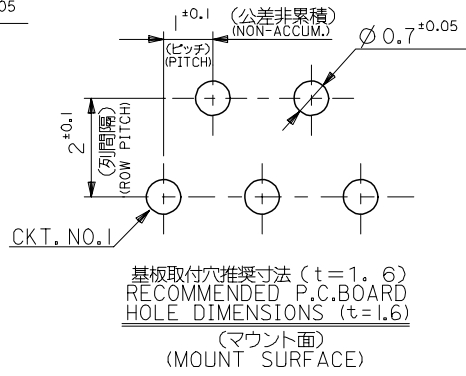
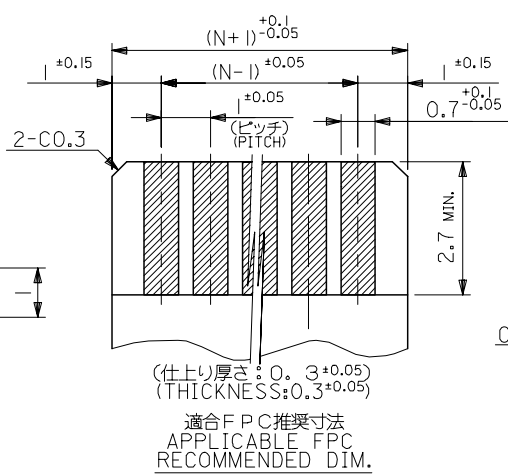
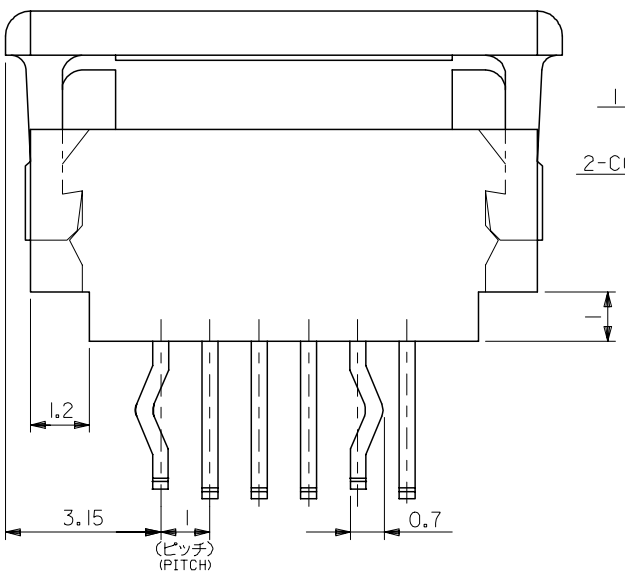
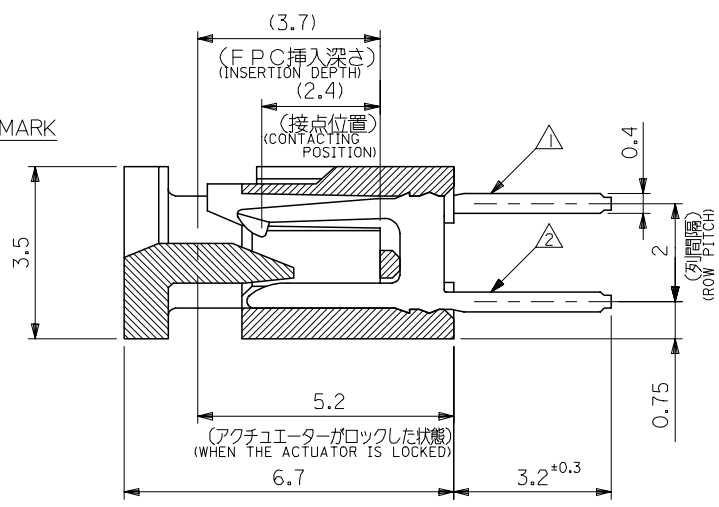
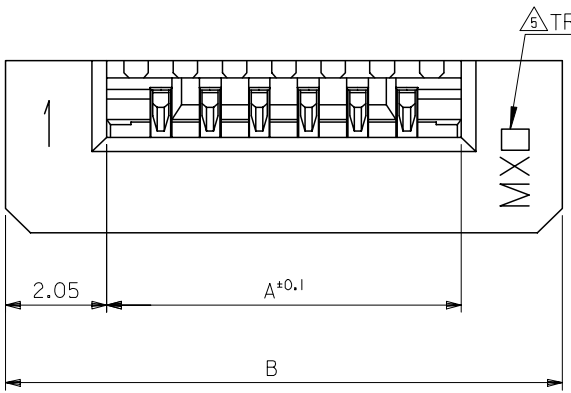

TRADE MARK
MADE IN JAPAN:MXJ
MADE IN MALAYSIA:MXL

FPCについて:
打抜き方向は導体側から補強板側を推奨致します。
補強フィルム材質はポリイミドを推奨致します。
接着剤は熱硬化接着剤を推奨致します。

ABOUT FPC:
RECOMMENDED PUNCHER DIRECTION :FORM CONDUCTOR SIDE TO STIFFENER BOARD SIDE.
RECOMMENDED MATERIAL :
STIFFENER FILM : POLYIMIDE
BONDING AGENT : THEROSETTING BONDING AGENT

35.3	31.2	52030-3029	30
34.3	30.2	-2929	29
33.3	29.2	-2829	28
32.3	28.2	-2729	27
31.3	27.2	-2629	26
30.3	26.2	-2529	25
29.3	25.2	-2429	24
28.3	24.2	-2329	23
27.3	23.2	-2229	22
26.3	22.2	-2129	21
25.3	21.2	-2029	20
24.3	20.2	-1929	19
23.3	19.2	-1829	18
22.3	18.2	-1729	17
21.3	17.2	-1629	16
20.3	16.2	-1529	15
19.3	15.2	-1429	14
18.3	14.2	-1329	13
17.3	13.2	-1229	12
16.3	12.2	-1129	11
15.3	11.2	-1029	10
14.3	10.2	-0929	9
13.3	9.2	-0829	8
12.3	8.2	-0729	7
11.3	7.2	-0629	6
10.3	6.2	-0529	5
9.3	5.2	-0429	4
8.3	4.2	52030-0329	3
B	A	MATERIAL NO.	極数 CKT.

注記:
 △ CKT. NO. 1を基準に偶数番目のソルダーテール。
 EVEN NUMBER SOLDER TAIL.
 △ CKT. NO. 1を基準に奇数番目のソルダーテール。
 ODD NUMBER SOLDER TAIL.
 3. 材料:
 MATERIAL:
 ターミナル: リン青銅, ニッケル下地, 錫ビスマスメッキ (t=0.32)
 TERMINAL: PHOSPHOR BRONZE, TIN-BISMUTH OVER NICKEL PLATING.(t=0.32)
 ハウジング: 66ナイロン, UL94V-0
 HOUSING: 66NYLON, UL94V-0
 アクチュエーター: ポリエステル, UL94V-0
 ACTUATOR: POLYESTER, UL94V-0
 4. 本製品は52030-***10の鉛フリー品である。
 THIS PRODUCT IS LEAD FREE OF 52030-***10.

REVISED EC NO: J2008-1613 DRWNY: A0YAGI 2007/10/30 CHKD: THARUYAMA 2007/10/30 APPR: NUKITA 2007/10/30	DESCRIPTION	GENERAL TOLERANCES (UNLESS SPECIFIED)		DIMENSION STYLE MM ONLY		SCALE 10:1	DESIGN UNIT'S METRIC	THIRD ANGLE PROJECTION	
		10 UNDER	±0.2	DRAWN BY YWADA	DATE '04/03/29	TITLE 1.0 FPC CONN ZIF ST			
		10 OVER 30 UNDER	±0.25	CHECKED BY MSASAO	DATE '04/03/29	-LEAD FREE-			
		30 OVER	±0.3	APPROVED BY MSASAO	DATE '04/03/29	MOLEX INCORPORATED			
ANGULAR ±3 °		DRAFT WHERE APPLICABLE MUST REMAIN WITHIN DIMENSIONS		MATERIAL NO. SEE TABLE		DOCUMENT NO. SD-52030-017		SHEET NO. 1 OF 1	
THIS DRAWING CONTAINS INFORMATION THAT IS PROPRIETARY TO MOLEX INCORPORATED AND SHOULD NOT BE USED WITHOUT WRITTEN PERMISSION									