

Plug-in Signal Conditioners K-UNIT

ANALOG ADDER

(two isolated outputs)

Functions & Features

- Receives two analog signals and outputs a signal proportional to their sum
- DC isolation between inputs and outputs
- High-density mounting

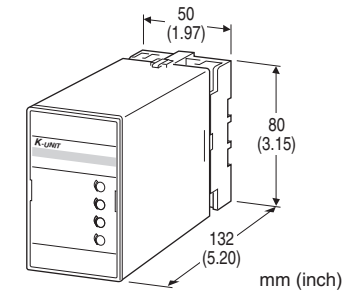

MODEL: KWADS-[1][2][3]-[4][5]

ORDERING INFORMATION

- Code number: KWADS-[1][2][3]-[4][5]
- Specify a code from below for each of [1] through [5].
(e.g. KWADS-6A6-B/Q)
- Special input and output ranges (For codes Z & 0)
- Parameters (e.g. K1 = 0.10, K2 = 2.00)
- Specify the specification for option code /Q
(e.g. /C01/S01)

Note: When the user requires a current and a voltage output, specify the current to be the Output 1 which allows a greater load.

[1] INPUT

Voltage

- 1: 0 - 10 mV DC (Input resistance 10 k Ω min.)
- 15: 0 - 50 mV DC (Input resistance 10 k Ω min.)
- 16: 0 - 60 mV DC (Input resistance 10 k Ω min.)
- 2: 0 - 100 mV DC (Input resistance 100 k Ω min.)
- 3: 0 - 1 V DC (Input resistance 1 M Ω min.)
- 4: 0 - 10 V DC (Input resistance 1 M Ω min.)
- 5: 0 - 5 V DC (Input resistance 1 M Ω min.)
- 6: 1 - 5 V DC (Input resistance 1 M Ω min.)
- 4W: -10 - +10 V DC (Input resistance 1 M Ω min.)
- 5W: -5 - +5 V DC (Input resistance 1 M Ω min.)
- 0: Specify voltage (See INPUT SPECIFICATIONS)

[2] OUTPUT 1

Current

- A: 4 - 20 mA DC (Load resistance 600 Ω max.)
- B: 2 - 10 mA DC (Load resistance 1200 Ω max.)
- C: 1 - 5 mA DC (Load resistance 2400 Ω max.)
- D: 0 - 20 mA DC (Load resistance 600 Ω max.)
- E: 0 - 16 mA DC (Load resistance 750 Ω max.)
- F: 0 - 10 mA DC (Load resistance 1200 Ω max.)
- G: 0 - 1 mA DC (Load resistance 12 k Ω max.)
- Z: Specify current (See OUTPUT SPECIFICATIONS)

Voltage

- 1: 0 - 10 mV DC (Load resistance 10 k Ω min.)
- 2: 0 - 100 mV DC (Load resistance 100 k Ω min.)
- 3: 0 - 1 V DC (Load resistance 1000 Ω min.)
- 4: 0 - 10 V DC (Load resistance 10 k Ω min.)
- 5: 0 - 5 V DC (Load resistance 5000 Ω min.)
- 6: 1 - 5 V DC (Load resistance 5000 Ω min.)
- 4W: -10 - +10 V DC (Load resistance 10 k Ω min.)
- 5W: -5 - +5 V DC (Load resistance 5000 Ω min.)
- 0: Specify voltage (See OUTPUT SPECIFICATIONS)

[3] OUTPUT 2

Current

- A: 4 - 20 mA DC (Load resistance 350 Ω max.)
- B: 2 - 10 mA DC (Load resistance 700 Ω max.)
- C: 1 - 5 mA DC (Load resistance 1400 Ω max.)
- D: 0 - 20 mA DC (Load resistance 350 Ω max.)
- E: 0 - 16 mA DC (Load resistance 430 Ω max.)
- F: 0 - 10 mA DC (Load resistance 700 Ω max.)
- G: 0 - 1 mA DC (Load resistance 7000 Ω max.)
- Z: Specify current (See OUTPUT SPECIFICATIONS)

Voltage

Same range availability as Output 1

[4] POWER INPUT

AC Power

- B: 100 V AC
- C: 110 V AC
- D: 115 V AC
- F: 120 V AC
- G: 200 V AC
- H: 220 V AC
- J: 240 V AC

DC Power

- S: 12 V DC
- R: 24 V DC

[5] OPTIONS

blank: none

/Q: With options (specify the specification)

SPECIFICATIONS OF OPTION: Q (multiple selections)

COATING (For the detail, refer to M-System's web site.)

/C01: Silicone coating

/C02: Polyurethane coating

/C03: Rubber coating

TERMINAL SCREW MATERIAL

/S01: Stainless steel

50/60 ±2 Hz, approx. 3 VA

•DC: Operational voltage range: rating ±10 %

ripple 10 %p-p max., approx. 3 W (125 mA at 24 V)

Operating temperature: -5 to +55°C (23 to 131°F)

Operating humidity: 30 to 90 %RH (non-condensing)

Mounting: Surface or DIN rail

Weight: 400 g (0.88 lb)

GENERAL SPECIFICATIONS

Construction: Plug-in

Connection: M3.5 screw terminals

Screw terminal: Chromated steel (standard) or stainless steel

Housing material: Flame-resistant resin (black)

Isolation: Input 1 or input 2 to output 1 to output 2 to power

Overrange output: Approx. -10 to +120 % at 1 - 5 V

Zero adjustment: -5 to +5 % (front)

Span adjustment: 95 to 105 % (front)

Adjustable individually for each output 1 and output 2.

Equation: Output = $K_1 \times$ Input 1 + $K_2 \times$ Input 2

K_1, K_2 : 0.10 - 2.00 (parameters)

Output, Input 1, Input 2: 0 - 100 %

K_1, K_2 are ex-factory specified.

Note: Be aware that a input signal less than 0 % is calculated as a minus signal.

PERFORMANCE in percentage of span

Accuracy: ±0.2 % (±0.4 % at K_1 and/or $K_2 > 1.00$)

Temp. coefficient: ±0.02 %/°C (±0.01 %/°F)

Response time: ≤ 0.5 sec. (0 - 90 %)

Line voltage effect: ±0.1 % over voltage range

Insulation resistance: ≥ 100 MΩ with 500 V DC

Dielectric strength: 2000 V AC @ 1 minute

(input to output to power to ground)

1000 V AC @ 1 minute (output 1 to output 2)

INPUT SPECIFICATIONS

■ **DC Voltage:** -300 - +300 V DC

Minimum span: 3 mV

Offset: Max. 1.5 times span

Input resistance

Span 3 - 10 mV : ≥ 10 kΩ

Span 10 - 100 mV : ≥ 10 kΩ

Span 0.1 - 1 V : ≥ 100 kΩ

Span ≥ 1 V : ≥ 1 MΩ

OUTPUT SPECIFICATIONS

■ **DC Current:** 0 - 20 mA DC

Minimum span: 1 mA

Offset: Max. 1.5 times span

Load resistance: Output drive 12 V max. for Output 1;

7 V max. for Output 2

■ **DC Voltage:** -10 - +12 V DC

Minimum span: 5 mV

Offset: Max. 1.5 times span

Load resistance: Output drive 1 mA max. at ≥ 0.5 V

INSTALLATION

Power input

•AC: Operational voltage range: rating ±10 %,

EXTERNAL DIMENSIONS & TERMINAL ASSIGNMENTS unit: mm (inch)

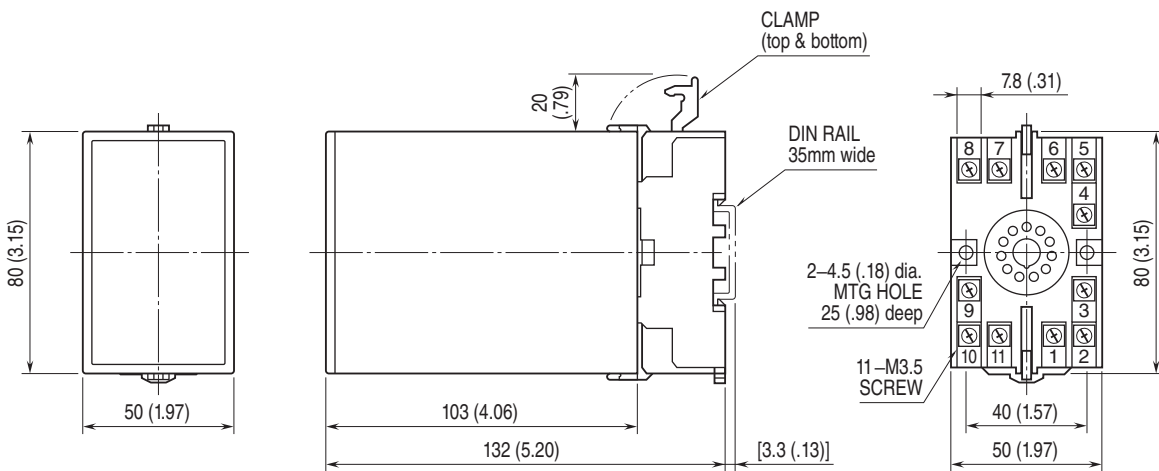

• When mounting, no extra space is needed between units.

SCHEMATIC CIRCUITRY & CONNECTION DIAGRAM

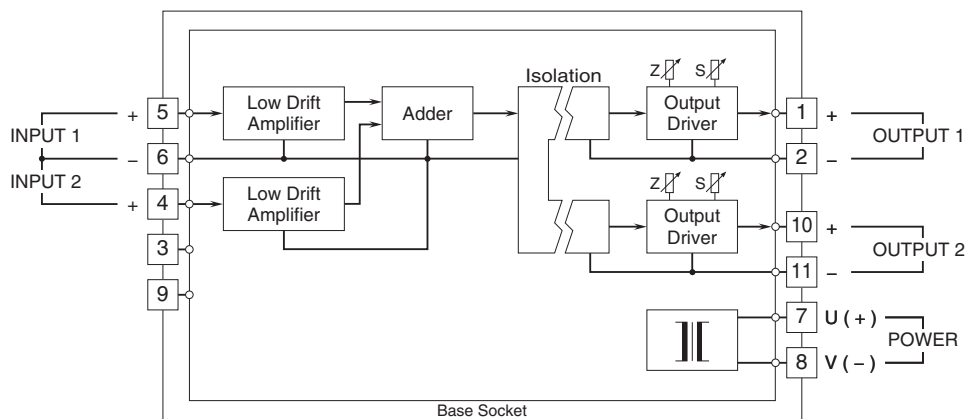

Specifications are subject to change without notice.